

SANMOTION

3-PHASE STEPPING SYSTEMS

F3

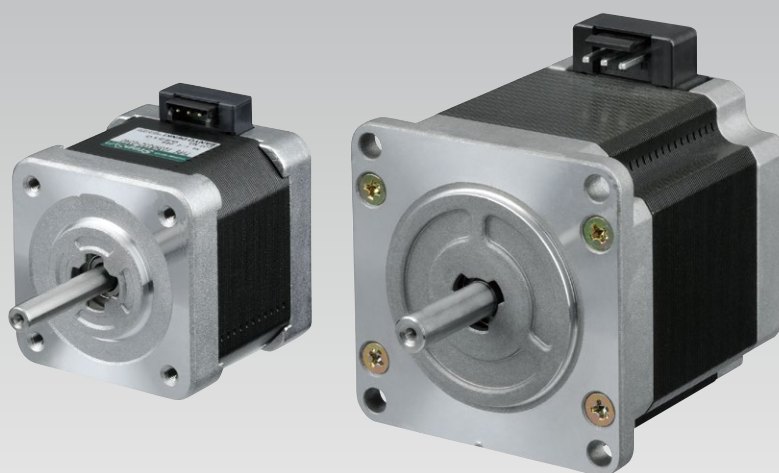

SANYO DENKI

Ver. **3.1**



Stepping Motor

Motor Size: 42 mm sq. to 60 mm sq.

SANMOTION F3 is a 3-phase stepping system that provides precise positioning with simple control. The typical basic step angle is 1.2°, precisely controlled by pulse signals.

System Configuration

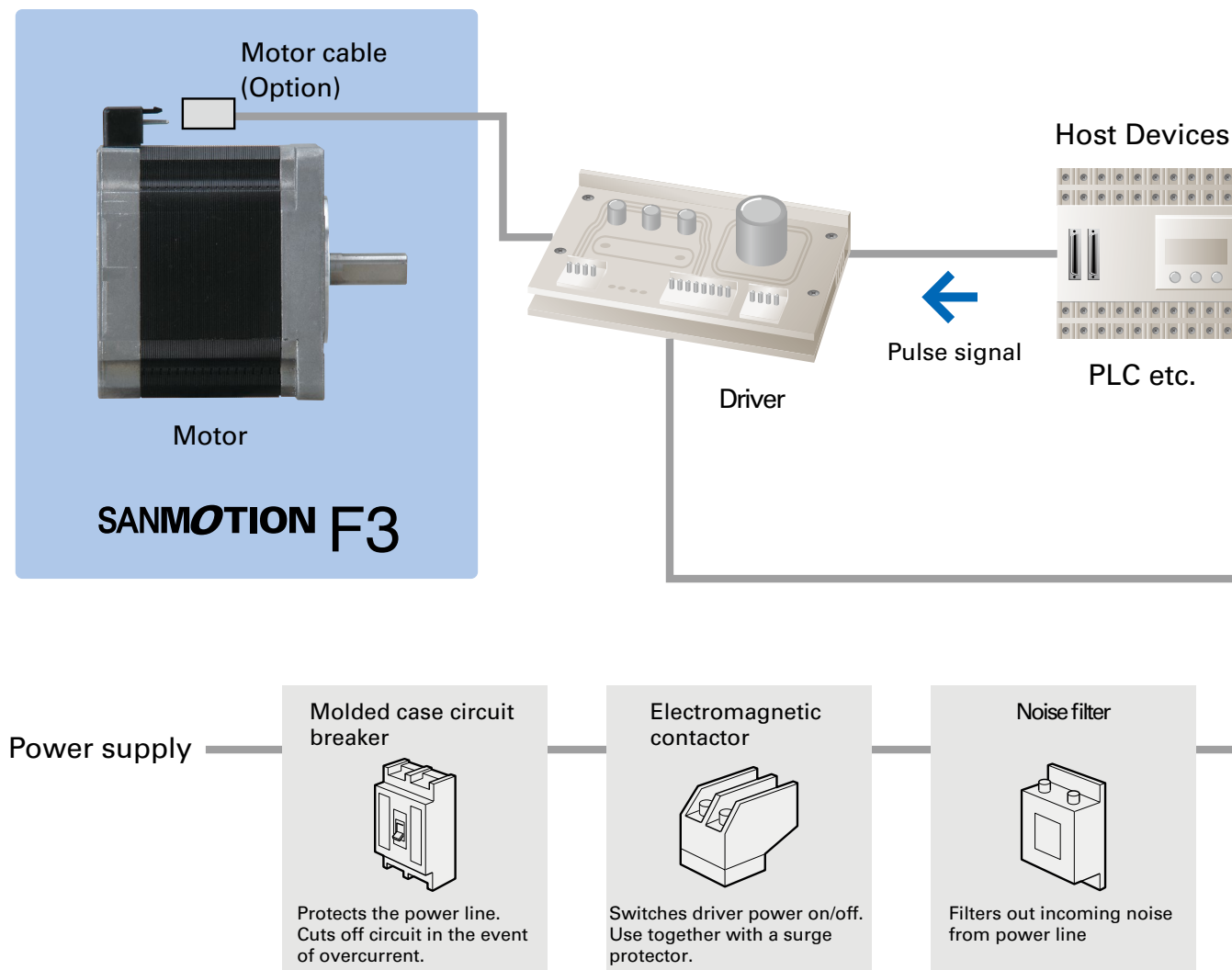

Set Model Configuration

Stepping Motor

Motor flange size	Basic step angle	Holding torque [N · m (oz · in) MIN.]	Model number	Page
42mm sq. (1.65inch sq.)	1.2°	0.196 (27.75)	103H5332-03□0	P.4
		0.265(37.53)	103H5333-03□0	P.4
50mm sq. (1.97inch sq.)	1.2°	0.44 (62.31)	103H6332-03□0	P.5
		0.58 (82.13)	103H6333-03□0	P.5
56mm sq. (2.20inch sq.)	1.2°	0.69 (97.71)	103H7332-03□0	P.6
		1.1 (155.77)	103H7333-03□0	P.6
60mm sq. (2.36inch sq.)	1.2°	0.95 (134.53)	103H7832-03□0	P.7
		1.68 (237.90)	103H7833-03□0	P.7

Stepping Motor



42mm sq. (1.65inch sq.)

1.2° /step
Motor with Connector

Model number		Holding torque at 2-phase energization	Rated current	Wiring resistance	Winding inductance	Rotor inertia	Mass (Weight)
Single shaft	Double shaft	N · m (oz · in) MIN.	A /phase	Ω /phase	mH /phase	× 10 ⁻⁴ kg · m ² (oz · in ²)	kg (lbs)
103H5332-0340	103H5332-0310	0.196 (27.75)	3	0.84	0.5	0.053 (0.29)	0.3 (0.66)
103H5333-0340	103H5333-0310	0.265 (37.53)	3	0.94	0.5	0.065 (0.36)	0.38(0.84)

Pulse rate-torque characteristics

103H5332-0340
103H5332-0310

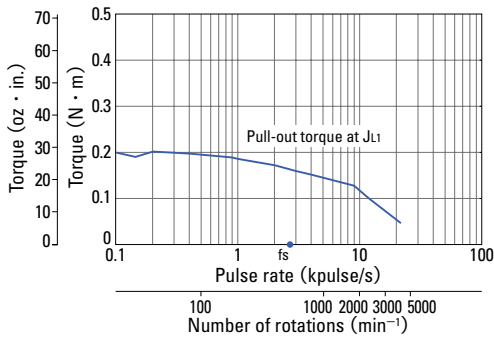

Constant current circuit
Source voltage : DC24V · operating current : 3 A/phase,
2-phase energization (full step)
[J_{L1}=0.94 × 10⁻⁴kg · m² (5.14oz · in²) use the rubber coupling.]

103H5333-0340
103H5333-0310

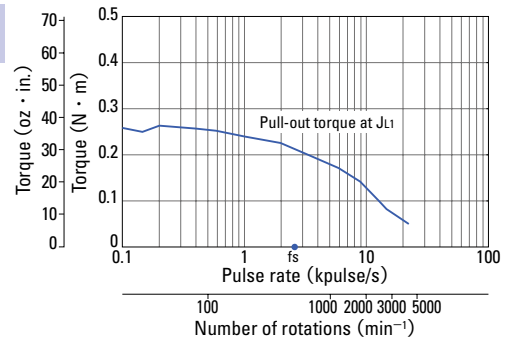

Constant current circuit
Source voltage : DC24V · operating current : 3 A/phase,
2-phase energization (full step)
[J_{L1}=0.94 × 10⁻⁴kg · m² (5.14oz · in²) use the rubber coupling.]

Dimensions [unit : mm(inch)]

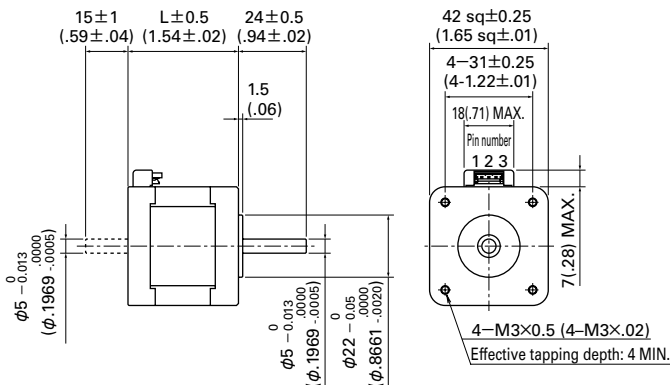

Set model number	Motor length(L) [mm(inch)]
103H5332-0340	39 (1.54 inch)
103H5332-0310	39 (1.54 inch)
103H5333-0340	48 (1.89 inch)
103H5333-0310	48 (1.89 inch)

Option: Motor cable Model No. : 4835611-1

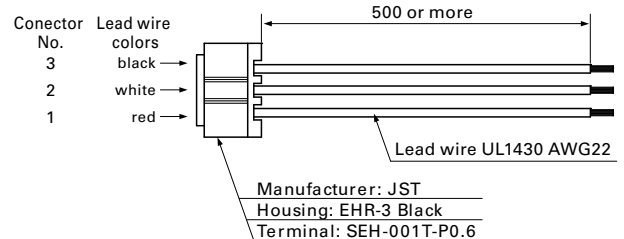

Cable for 42 mm sq. motor (between motor and driver)



50mm sq. (1.97inch sq.)

1.2° /step
Motor with Connector

Model number		Holding torque at 2-phase energization	Rated current	Wiring resistance	Winding inductance	Rotor inertia	Mass (Weight)
Single shaft	Double shaft	N · m (oz · in) MIN.	A/phase	Ω /phase	mH/phase	× 10 ⁻⁴ kg · m ² (oz · in ²)	kg (lbs)
103H6332-0340	103H6332-0310	0.44 (62.31)	3	1.3	1.6	0.12 (0.66)	0.5 (1.10)
103H6333-0340	103H6333-0310	0.58 (82.13)	3	1.6	1.6	0.17 (0.93)	0.65 (1.43)

Pulse rate-torque characteristics

103H6332-0340
103H6332-0310

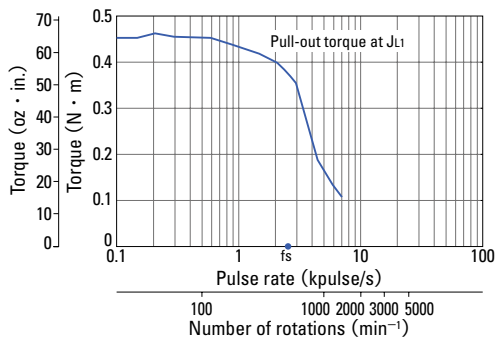

Constant current circuit
Source voltage : DC24V · operating current : 3 A/phase,
2-phase energization (full step)
[J_{L1}=0.94 × 10⁻⁴kg · m² (5.14oz · in²) use the rubber coupling.]

103H6333-0340
103H6333-0310

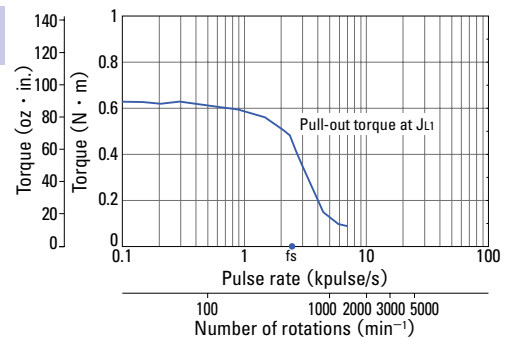

Constant current circuit
Source voltage : DC24V · operating current : 3 A/phase,
2-phase energization (full step)
[J_{L1}=0.94 × 10⁻⁴kg · m² (5.14oz · in²) use the rubber coupling.]

Dimensions [unit : mm(inch)]

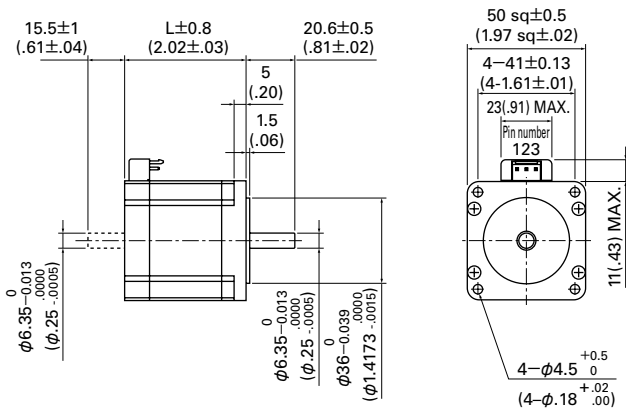

Set model number	Motor length(L) [mm(inch)]
103H6332-0340	51.3 (2.02 inch)
103H6332-0310	51.3 (2.02 inch)
103H6333-0340	64.8 (2.55 inch)
103H6333-0310	64.8 (2.55 inch)

Option: Motor cable Model No. : 4837978-1

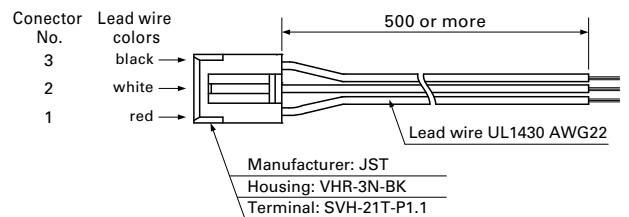

Cable for 50, 56, 60 mm sq. motor (between motor and driver)



56mm sq. (2.20inch sq.)

1.2° /step
Motor with Connector

Model number		Holding torque at 2-phase energization	Rated current	Wiring resistance	Winding inductance	Rotor inertia	Mass (Weight)
Single shaft	Double shaft	N · m (oz · in) MIN.	A/phase	Ω /phase	mH/phase	× 10 ⁻⁴ kg · m ² (oz · in ²)	kg (lbs)
103H7332-0340	103H7332-0310	0.69 (97.71)	3	1.4	1.8	0.21 (1.15)	0.65 (1.43)
103H7333-0340	103H7333-0310	1.1 (155.77)	3	1.7	2.4	0.36 (1.97)	0.98 (2.16)

Pulse rate-torque characteristics

103H7332-0340
103H7332-0310

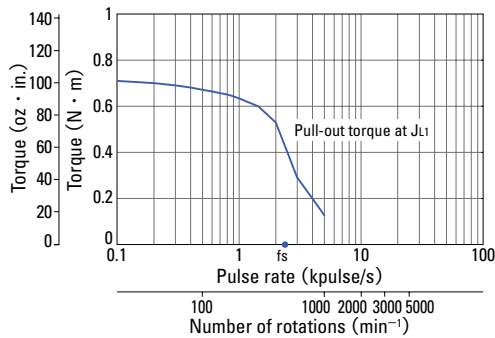

Constant current circuit
Source voltage : DC24V · operating current : 3 A/phase,
2-phase energization (full step)
[J_{L1}=0.94 × 10⁻⁴kg · m² (5.14oz · in²) use the rubber coupling.]

103H7333-0340
103H7333-0310

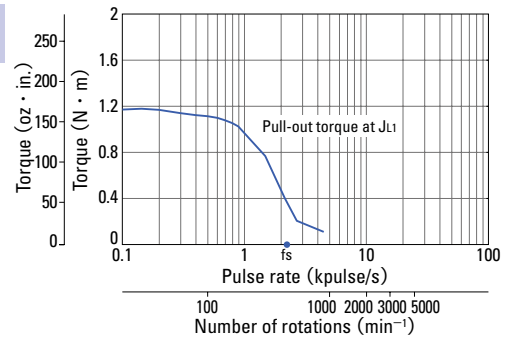

Constant current circuit
Source voltage : DC24V · operating current : 3 A/phase,
2-phase energization (full step)
[J_{L1}=2.6 × 10⁻⁴kg · m² (14.22oz · in²) use the rubber coupling.]

Dimensions [unit : mm(inch)]

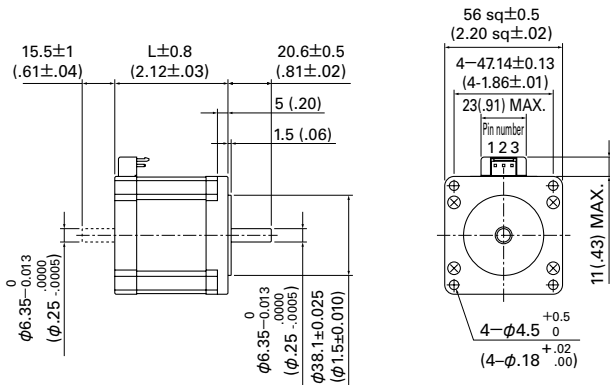

Set model number	Motor length(L) [mm(inch)]
103H7332-0340	53.8 (2.12 inch)
103H7332-0310	53.8 (2.12 inch)
103H7333-0340	75.8 (2.98 inch)
103H7333-0310	75.8 (2.98 inch)

Option: Motor cable Model No. : 4837978-1

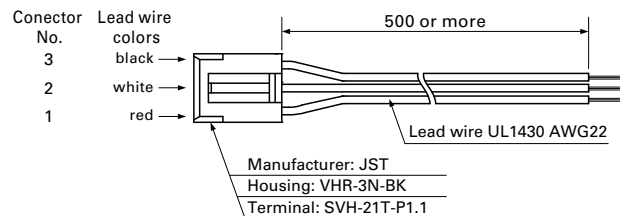

Cable for 50, 56, 60 mm sq. motor (between motor and driver)



60mm sq. (2.36inch sq.)

1.2° /step
Motor with Connector

Model number		Holding torque at 2-phase energization	Rated current	Wiring resistance	Winding inductance	Rotor inertia	Mass (Weight)
Single shaft	Double shaft	N · m (oz · in) MIN.	A/phase	Ω /phase	mH/phase	× 10 ⁻⁴ kg · m ² (oz · in ²)	kg (lbs)
103H7832-0340	103H7832-0310	0.95 (134.53)	3	1.5	1.8	0.4 (2.19)	0.78 (1.72)
103H7833-0340	103H7833-0310	1.68 (237.90)	3	2	3.2	0.84 (4.59)	1.34 (2.95)

Pulse rate-torque characteristics

103H7832-0340
103H7832-0310

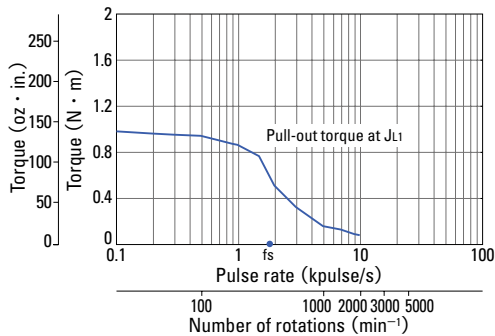

Constant current circuit
Source voltage : DC24V · operating current : 3 A/phase,
2-phase energization (full step)
[J_{L1}=2.6 × 10⁻⁴kg · m² (14.22oz · in²) use the rubber coupling.]

103H7833-0340
103H7833-0310

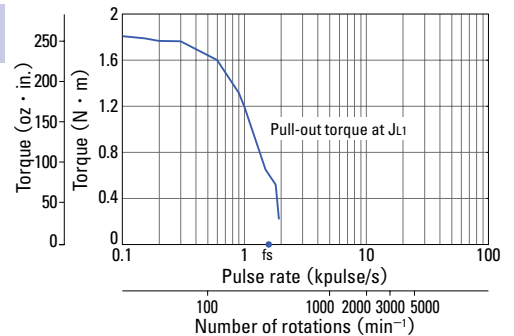

Constant current circuit
Source voltage : DC24V · operating current : 3 A/phase,
2-phase energization (full step)
[J_{L1}=7.4 × 10⁻⁴kg · m² (40.46oz · in²) use the rubber coupling.]

Dimensions [unit : mm(inch)]

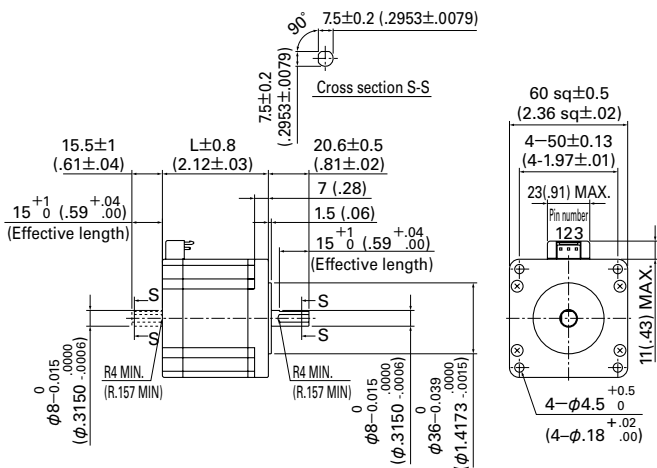

Set model number	Motor length(L) [mm(inch)]
103H7832-0340	53.8 (2.12 inch)
103H7832-0310	53.8 (2.12 inch)
103H7833-0340	85.8 (3.38 inch)
103H7833-0310	85.8 (3.38 inch)

Option: Motor cable Model No. : 4837978-1

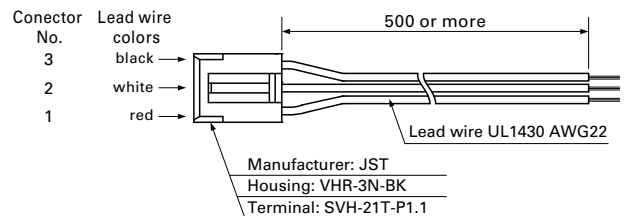

Cable for 50, 56, 60 mm sq. motor (between motor and driver)

Allowable radial / thrust load

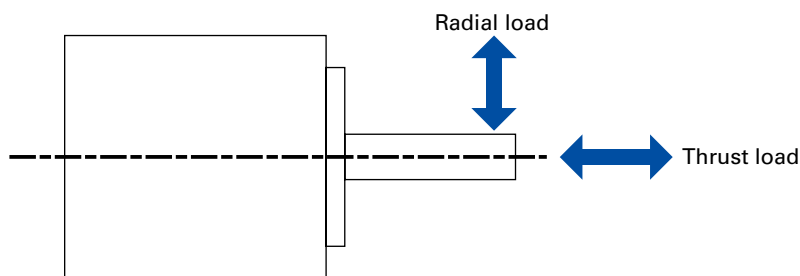

Frange size	Model number	Distance from end of shaft : mm (inch)				Thrust load : N (lbs)
		0 (0)	5 (.2)	10 (2.25)	15 (3.38)	
		Radial load : N(lbs)				
42mm sq. (1.65inch sq.)	103H533 □	25 (6)	30 (6)	38 (8)	53 (11)	10 (2.25)
50mm sq. (1.97inch sq.)	103H633 □	71 (15)	88 (19)	115 (25)	167 (37)	15 (3.37)
56mm sq. (2.2inch sq.)	103H733 □	65 (14)	80 (17)	105 (23)	153 (34)	15 (3.37)
60mm sq. (2.36inch sq.)	103H783 □	85 (19)	105 (23)	138 (31)	201 (44)	20 (4.50)

Internal connection and rotational direction

Internal connection

() Connector pin number

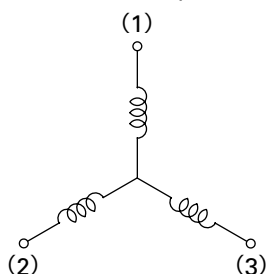

Direction of motor rotate

When DC-energized in the order below, the rotational direction must be counterclockwise viewed from the output axis side.

Type		Conector type pin number		
		(1)	(2)	(3)
Energization order	1	+	-	
	2	+		-
	3		+	-
	4	-	+	
	5	-		+
	6		-	+

General specifications

Model number	103H533 □	103H633 □	103H733 □	103H783 □
Ambient operation temperature	- 10 ~ + 50°C			
Storage temperature	- 20 ~ + 65°C			
Ambient operation humidity	20 ~ 90% RH (no condensation)			
Storage humidity	5 ~ 95% RH (no condensation)			
Vibration resistance	Vibration frequency 10 to 500 Hz, total amplitude 1.52 mm (10 to 70 Hz), vibration acceleration 147 m/s ² (70 to 500 Hz), sweep time 15 min/cycle, 12 sweeps in each X, Y and Z direction.			
Impact resistance	490m/s ² of acceleration for 11 ms with half-sine wave applying three times for X, Y, and Z axes each, 18 times in total.			
Insulation class	Class B (+130°C)			
Withstand voltage	1000 VAC (500 VAC for 103H533 □) for one minute (between motor winding and frame)			
Insulation resistance	100 MΩ or more at 500 VDC (between motor winding and frame)			
Protection grade	IP40			
Wiringtemperature increase	80 K MAX. (Based on Sanyo Denki standard.)			
Standing angle error	± 0.06°			
Axial play ^(Note 1)	0.075 mm (0.003 inch) MAX. Load : 4.4N (1 lbs)		0.075 mm (0.003 inch) MAX. Load : 9N (2 lbs)	
Radial play ^(Note 2)	0.075 mm (0.003 inch) MAX. Load : 4.4N (1lbs)			
Shaft runout	0.025mm (0.001 inch)			
Concentricity of mounting spigot relative to shaft	φ 0.05mm (0.002 inch)	φ 0.075mm (0.003 inch)		
Perpendicularity of mounting surface relative to shaft	0.1mm (0.004 inch)	0.075mm (0.003 inch)		

(Note1) Axial play: Shaft displacement under axial load.

(Note2) Radial play: Shaft displacement under radial load applied 1/3rd of the length from the end of the shaft.

Safety Consideration

The stepping motors are the products designed to be used for the general industrial devices. When using those, pay enough attention to the following points.

- Read the instructions carefully before installation and assembly, to ensure correct usage. Manuals can be downloaded from our website.
- Refrain from modifying or processing the product in any way.
- Consult with the distributor or professional experts for placement or maintenance services of the product.
- In case of the following uses of the product, contact with us for the special care required to the operation, maintenance and management such as multiplexing the system, installing an emergency electric generator set, or so forth.
 - ① Use for the medical devices concerned with a fatal accident.
 - ② Use for trains, elevators, and so forth that are likely to cause an accident resulting in injury, damage or death.
 - ③ Use in the computer system highly influential to the social life or the public systems.
 - ④ Use in other devices highly influential to maintaining the human safety or the public functions.

In addition to the above, consult with us for use in such a vibration environment as automobile or transportation. Make yourself knowledgeable and familiarize with the devices, safety issues and cautions before handling the product.

Indication by (Warning Label) on the product

Either or all of the following indications are given by the Warning Labels depending on the type of the stepping motor.



This label is stuck near the high voltage part such as the electrically charged or cover-protected section, warning that the place where it is likely to cause an electric shock.



This label is stuck near the GND terminals of the stepping motor for which grounding is required, suggesting that the terminals should be actually grounded.



This label is stuck for the stepping motor to which the power source is applied in the voltage exceeding the safety standard, drawing attention against the electric shock.

Safety ranks of the cautions

Following four ranks are provided.



DANGER Improper operations or use is most likely to result in serious injury or death.



CAUTION Improper operations or use is likely to result in average or minor injury, or in property damage.

In spite of the cautions with the  CAUTION label, it may cause serious results. Either the contents of the labels is describing important cautions to be followed inevitably.



PROHIBITED Indicates what shall not be done.



COMPULSORY Indicates what shall be done.



<General matters>

1. Do not use the product in an explosive, flammable or corrosive atmosphere, watery place or near a combustible material. Doing so may cause injury or fire.
2. Have a person with expert knowledge for performing the transportation ,placement,wiring, operation, maintenance or inspection of the product. Without such knowledge, it may cause an electric shock, injury or fire.
3. Do not work for wiring, maintenance servicing or inspection with the electric power on. Perform either of those five minutes after turning the power off, or otherwise, it may cause an electric shock.
4. When the protective functions of the product is activated, turn the power off immediately and eliminate the cause. If continuing the operation without eliminating the cause, the product may operate improperly and cause injury or a breakdown of the system devices.
5. Stepping motor may run out of order at the operating and stopping occasions, depending on the magnitude of the load. Put the product into use after confirming with the adequate trial test operation in the maximum load conditions that the product performs reliable operation. Doing otherwise may cause a breakdown of the system. (Should the product run out of order in the use to drive upward/downward, it may cause a fall of the load.)
6. Do not touch the internal parts. Doing so may cause an electric shock.

<Wiring>

7. Do not connect the stepping motor directly with the commercial power outlet. Doing so may cause an electric shock, injury or fire. The power shall be supplied to the stepping motor through the driving circuit.
8. Use the electric power source within the rated input voltage. Using otherwise may cause fire or an electric shock.
9. Connect the stepping motor to the ground. Using without grounding may cause an electric shock.
10. Do not harm, forcibly put a stress, or load a heavy article on the cable or get it caught between the articles. Doing so may cause an electric shock.
11. Perform wiring with the power cable as instructed by the wiring diagram. Doing otherwise may cause an electric shock or fire.

<Operation>

12. Be sure not to touch the rotating part of the stepping motor during its operation. Touching it may cause injury.
13. Neither reach or touch the electric terminals while electric power is on. Doing so may cause an electric shock.
14. Never disconnect any of the connectors while electric power is on. Doing so may cause an electric shock and corruption.



<General matters>

1. Do not use the driver or the stepping motor outside the specified conditions. Doing so may cause an electric shock, injury or fire.
2. Do not insert a finger or a thing into the opening of the product. Doing so may cause an electric shock, injury or fire.
3. Do not use the damaged driver or stepping motor. Doing so may cause injury, fire or the like.
4. Use the driver and stepping motor in the designated combination. Using otherwise may cause fire or a trouble.
5. Be careful that the temperature rises in the operating driver, stepping motor or peripheral devices. Failure to be careful may cause a burn.

<Unpacking>

6. Unpack while confirming the ceiling. Failure to do so may cause injury.
7. Confirm if the product is the one having been ordered. Installing an incorrect product may cause a breakdown.

<Wiring>

8. Do not perform measurement of the insulation resistance or withstand insulation voltage of the product. Doing so may cause a breakdown. Instead, contact with us for such inspection.
9. Perform wiring conforming to the technical standards of electric facility or the internal rule. Doing otherwise may cause burning or fire.
10. Ensure that wiring has been correctly done. Operating without correct wiring may cause the stepping motor to run out of control and result in injury.
11. Take insulation process for the attached condenser or the external resistance connection terminals. Failure to do so may cause an electric shock.

<Placement>

12. Do not climb or attach a heavy article on the product. Doing so may cause injury.
13. Neither block nor stuff the aspiration/exhaust vent with a foreign particle. Doing so may cause fire.
14. Follow the instructions for the direction to place. Failure to do so may cause a trouble.

15. Place the product with a great care so as to prevent from the danger such as a tumble or a turnover.
16. Mount the product on an incombustible material such as metal. Doing otherwise may cause fire.
17. Confirm the rotating direction before connecting with the mechanical device. Failure to do so may cause injury or a breakdown.
18. Do not touch the motor output spindle (including the key slot and gears) with a bare hand. Doing so may cause injury.

<Operation>

19. The stepping motor is not equipped with any protective device. Take protective measures using an over-current protective relay, a ground fault interrupter, a protective device from excess temperature, and an emergency stopping device. Failure to do so may cause injury or fire.
20. Do not touch the product for a period after the power is on or has been turned off, since the driver and stepping motor remain in the high temperature. Doing so may cause burns. Especially the temperature rises considerably of the stepping motor depending on the operating conditions. Use the motor on the condition so that its surface temperature becomes 100° C or under
21. Stop the operation immediately when an emergency occurs. Failure to do so may cause an electric shock, injury or fire.
22. Do not change adjustment to an extreme, for such a change results in the unstable operation. Doing so may cause injury.
23. When conducting the trial operation, make the stepping motor fixed firmly, and confirm the operation by disconnecting with the mechanical system before connecting with it. Failure to do so may cause injury.
24. When the alarm has been activated, eliminate the cause and ensure the safety to resume operation. Failure to do so may cause injury.
25. When the electric power recovers after the momentary interruption, do not approach the devices because the system may re-start operation by itself. (Set the system so as to secure the safety even when it re-start on such occasion.) Failure to do so may cause injury.
26. Confirm that the electric power supply is all proper conforming to the specifications. Failure to do so may cause a trouble.
27. The brake mechanism of the motor with the electro-magnetic brake is to hold the movable section and the motor position. Do not use it as a safety measure, or doing so may cause the breakdown of the system.
28. Fix the key firmly when operating the motor with key individually. Failure to do so may cause injury.

<Maintenance services>

29. Be careful when performing maintenance services or inspection about the temperature which rises highly in the driver and stepping motor frame. Failure to do so may cause burns.
30. Contact with us for repair. If the product is disassembled by the user, it may put it out of action.

<Transportation>

31. Handle the product with care during transportation so as to prevent from the danger such as a tumble or a turnover.
32. Do not hold with the cable or the motor spindle. Doing so may cause a trouble or injury.

<Retirement>

33. When scrapping the stepping motor, treat it for the general industrial waste.



<Storage>

1. Avoid the place exposed to rain or water drops, or in an environment with hazardous gas or liquid for storing the product. Failure to do so may cause a trouble.

<Maintenance services>

2. Do not assemble or repair the product. Doing so may cause fire or an electric shock.

<General matters>

3. Do not remove the rating plate.



<Storage>

1. Store the product within the specified conservation temperature and humidity in the place not exposed to the sun beam.

<Operation>

2. Install an external emergency stop circuit to turn the power off for the instant halt of operation.
3. Put the product into operation in the specified ambient temperature and humidity.

<Transportation>

4. Excess loading of the product on the carrier may cause the load to fall in pieces. Follow the instructions given outside the package.

Inquiry Check Sheet

For more information regarding any products or services described here in, please contact your nearest office listed on the back of this catalog.

To SANYO DENKI Co.,LTD.

Date : _____

Company: _____

Department: _____

Name: _____

Tel: _____

FAX: _____

E-mail: _____

Item	Contents	
①	Name of target equipment	Equipment name, category (transport, processing, test, other)
②	Name of servo axis	Axis name, axial mechanism (horizontal/vertical), brake mechanism (yes/no)
③	Current condition of above axis	Manufacturer Name () Series Name () Motor Capacity () Hydraulic, Mechanical, or New System ()
④	Positioning accuracy	± mm± μm
⑤	Operation pattern	<p>Acceleration α: ___ G: ___ [m/s²] Feeding Speed V: ___ [m/s] Moving Distance D: ___ [m] (Stroke)</p> <p>Time [sec]</p> <p>← t1 () → ← t2 () → ← t3 () →</p> <p>[Reference formula] $1G=9.8[m/s^2]$, $1[m/s^2] \approx 0.1G$ $\alpha[m/s^2]=V[m/sec] \div t1[sec]$ $D[m]=V[m/sec] \times (t1+t2)[sec]$</p>
⑥	Mechanism	Ball-screw/screw-rotation type (horizontal/vertical), ball-screw/nut-rotation type (horizontal/vertical), rack and pinion (horizontal/vertical), belt/chain (horizontal/vertical), rotary table, roll feed, other
⑦	Mechanical structure	WT(table mass) kg WL(work mass) kg WA(mass of other drive parts) kg WR(rack mass) kg WB(belt/chain mass) kg WC(counterbalance mass) kg Fa(external force axial direction) N Fb(ball-screw preload) N T(roll pushing force) N Dr1(drive-side roll diameter) mm Dr2(follower-side roll diameter) mm
		Lr1(drive-side roll length) mm Lr2(follower-side roll length) mm G(reduction ratio) JG(speed-reducer inertia) kg·m ² JC(coupling inertia) kg·m ² JN(nut inertia) kg·m ² JO(other motor-axis conversion inertia) kg·m ² Db(ball-screw diameter) mm Lb(ball-screw axial length) mm Pb(ball-screw lead) mm
		Dp(pinion/pulley diameter) mm Lp(pinion axial length) mm tp(pully thickness) mm Dt(table diameter) mm Dh(table-support diameter) mm LW(load shift from axis) mm Ds(table shaft diameter) mm Ls(table shaft length) mm
		ρ (specific gravity of ball-screw/pinion/pulley/table-shaft material) kg·cm ³ μ (friction coefficient between sheet and shiliding-surface/support-section/roll) $\rho 1$ (specific gravity of roll-1 material) kg/cm ³ $\rho 2$ (specific gravity of roll-2 material) kg/cm ³ κ (internal friction coefficient of preload nut)
		η (mechanical efficiency) JL(load inertia of motor-axis conversion) kg·m ² TF(friction torque of motor axis conversion) N·m Tu(imbalance torque of motor axis conversion) N·m
⑧	Speed reducer	Customer-provided (/)-Sanyo denki standard(planet/spur/no-backlash-planet /) other(/)
⑨	Encoder type	Encoder type specified (yes / no) Yes:(Wiring saving incremental encoder, battery backup absolute encoder, absolute encoder for incremental system, battery-less absolute encoder) Resolution()
⑩	Input format	Position , velocity , torque , other ()
⑪	Host equipment (controller)	Sequencer , laptop , customer-developed product , Sanyo dennki-provided , other ()
⑫	Usage environment and other requirements	Cutting , clean-room use , anti-dust measures , other ()
⑬	Estimated production	Single product: () units/month () units/year
⑭	Development schedule	Prototype period: ()Year () Month Production period: ()Year () Month
⑮	Various measures	Related documentation (already submitted; send later by mail) Visit/PR desired (yes / no) Meeting desired (yes / no)
⑯	Miscellaneous (questions, pending problems, unresolved issues, etc.)	

Notes before Purchase

The products in this catalog are designed to be used with general industrial devices.

Always follow the following precautions.

- Read the accompanying Instruction Manual carefully prior to using the product.
- If applying to medical devices and other equipment affecting people's lives, please contact us beforehand and take appropriate safety measures.
- If applying to equipment that can have significant effects on society and the general public, please contact us beforehand.

· Do not use this product in an environment where vibration is present, such as in a moving vehicle or shipping vessel.

· Do not perform any retrofitting, re-engineering, or modification to this equipment.

· The products presented in this catalog are meant to be used for general industrial applications. If using for special applications related to aviation and space, nuclear power, electric power, submarine repeaters, and the like, please contact us beforehand.

SANYO DENKI CO., LTD. 3-33-1 Minami-Otsuka, Toshima-ku, Tokyo 170-8451, Japan TEL: +81 3 5927 1020

<https://www.sanyodenki.com/>

The names of companies and/or their products specified in this catalog are the trade names, and/or trademarks and/or registered trademarks of such respective companies.

SANMOTION is a trademark of SANYO DENKI CO., LTD.

Specifications are subject to change without notice.

CATALOG No. S0833B013 '22.4