

Rodless cylinder with brake

SRT3 Series

- Bore size: $\varnothing 12$, $\varnothing 16$, $\varnothing 20$, $\varnothing 25$, $\varnothing 32$
 $\varnothing 40$, $\varnothing 50$, $\varnothing 63$ or equiv.



Specifications

Item		SRT3							
Bore size	mm	$\varnothing 12$	$\varnothing 16$	$\varnothing 20$	$\varnothing 25$	$\varnothing 32$	$\varnothing 40$	$\varnothing 50$	$\varnothing 63$
Actuation		Double acting							
Working fluid		Compressed air							
Max. working pressure MPa		0.7 (≈ 100 psi, 7 bar)							
Min. working pressure	Cylinder MPa	0.2 (≈ 29 psi, 2 bar)			0.15 (≈ 22 psi, 1.5 bar)			0.1 (≈ 15 psi, 1 bar)	
	Brake section MPa	0.3 (≈ 44 psi, 3 bar) (Note)							
Proof pressure MPa		1.05 (≈ 150 psi, 10.5 bar)							
Ambient temperature $^{\circ}\text{C}$		5 (41°F) to 60 (140°F)							
Port size	Cylinder	M5		Rc1/8		Rc1/4		Rc3/8	
	Brake section	M5		Rc1/8					
Stroke tolerance	mm	$^{+2.0}_0$ (up to 1000), $^{+2.5}_0$ (up to 2000)							
Working piston speed	mm/s	50 to 1000							
Cushion		Air cushion							
Lubrication		Not required (use turbine oil class 1 ISO VG32 if necessary for lubrication)							
Holding force	N	66	118	184	288	483	754	1178	1870

Note: The min. working pressure of the brake is a value when a good load balance is achieved.

Allowable absorbed energy

Bore size (mm)	Cushioned		Without cushion
	Max absorbed energy (J)	Cushion stroke (mm)	Max absorbed energy (J)
$\varnothing 12$ or equiv.	0.03	14.5	0.003
$\varnothing 16$ or equiv.	0.22	19.2	0.007
$\varnothing 20$ or equiv.	0.59	22.2	0.010
$\varnothing 25$ or equiv.	1.40	20.9	0.015
$\varnothing 32$ or equiv.	2.57	23.5	0.030
$\varnothing 40$ or equiv.	4.27	23.9	0.050
$\varnothing 50$ or equiv.	9.13	24.9	0.072
$\varnothing 63$ or equiv.	17.4	29.6	0.138

Stroke length

Bore size (mm)	Standard stroke (mm)	Max. stroke length (mm)	Min. stroke length (mm)
$\varnothing 12$ or equiv.	200/300 400/500 600/700 800/900 1000	1000	1
$\varnothing 16$ or equiv.			
$\varnothing 20$ or equiv.			
$\varnothing 25$ or equiv.			
$\varnothing 32$ or equiv.			
$\varnothing 40$ or equiv.	1500		
$\varnothing 50$ or equiv.			
$\varnothing 63$ or equiv.			
		2000	

* The custom stroke length is available in 1 mm increments.

Number of installed M type switches and min. stroke length (mm)

Switch quantity	1																		2		3		4		5		6		7		8		9	
	Switch model No.																		M*V		M*H		M*V		M*H		M*V		M*H		M*V		M*H	
	Bore size (mm)																		M*V	M*H	M*V	M*H	M*V	M*H	M*V	M*H	M*V	M*H	M*V	M*H	M*V	M*H	M*V	M*H
$\varnothing 12$ or equiv.	10	10	30	45	60	90	90	135	120	180	150	225	180	270	210	315	240	360																
$\varnothing 16$ or equiv.	10	10	30	45	60	90	90	135	120	180	150	225	180	270	210	315	240	360																
$\varnothing 20$ or equiv.	10	10	30	45	60	90	90	135	120	180	150	225	180	270	210	315	240	360																
$\varnothing 25$ or equiv.	10	10	30	45	60	90	90	135	120	180	150	225	180	270	210	315	240	360																
$\varnothing 32$ or equiv.	10	10	30	45	60	90	90	135	120	180	150	225	180	270	210	315	240	360																
$\varnothing 40$ or equiv.	10	10	30	45	60	90	90	135	120	180	150	225	180	270	210	315	240	360																
$\varnothing 50$ or equiv.	15	15	30	45	60	90	90	135	120	180	150	225	180	270	210	315	240	360																
$\varnothing 63$ or equiv.	15	15	30	45	60	90	90	135	120	180	150	225	180	270	210	315	240	360																

Number of installed T type switches and min. stroke length (mm)

Switch quantity	1																		2		3		4		5		6		7		8		9	
	Switch model No.																		T*V		T*H		T*V		T*H		T*V		T*H		T*V		T*H	
	Bore size (mm)																		T*V	T*H	T*V	T*H	T*V	T*H	T*V	T*H	T*V	T*H	T*V	T*H	T*V	T*H	T*V	T*H
$\varnothing 12$ or equiv.	5	5	45	50	90	100	135	150	180	200	225	250	270	300	315	350	360	400																
$\varnothing 16$ or equiv.	5	5	45	50	90	100	135	150	180	200	225	250	270	300	315	350	360	400																
$\varnothing 20$ or equiv.	5	5	45	50	90	100	135	150	180	200	225	250	270	300	315	350	360	400																
$\varnothing 25$ or equiv.	10	10	45	50	90	100	135	150	180	200	225	250	270	300	315	350	360	400																
$\varnothing 32$ or equiv.	10	10	45	50	90	100	135	150	180	200	225	250	270	300	315	350	360	400																
$\varnothing 40$ or equiv.	10	10	45	50	90	100	135	150	180	200	225	250	270	300	315	350	360	400																
$\varnothing 50$ or equiv.	10	10	45	50	90	100	135	150	180	200	225	250	270	300	315	350	360	400																
$\varnothing 63$ or equiv.	10	10	45	50	90	100	135	150	180	200	225	250	270	300	315	350	360	400																

Switch specifications (M type switch)

- 1-color/2-color display

Item	Proximity 2-wire		Proximity 3-wire		
	M2V,M2H	M2WV (2-color display)	M3H/M3V	M3PH/M3PV (made to order)	M3WV
Applications	Dedicated for programmable controller		For programmable controller, relay, IC circuit, compact solenoid valve		
Output method	-		NPN output	PNP output	NPN output
Power supply voltage	-		4.5 to 28 VDC		10 to 28 VDC
Load voltage	10 to 30 VDC		30 VDC or less		
Load current	5 to 30 mA		100 mA or less	100 mA or less	100 mA or less
Indicator lamp	LED (Lit when ON)	Red/green LED (Lit when ON)	LED (Lit when ON)	Yellow LED (Lit when ON)	Red/green LED (Lit when ON)
Leakage current	1 mA or less		10 µA or less	0.05 mA or less	10 µA or less
Weight	g 1 m:22 3 m:57 5 m:93				
Item	MOV, MOH		M5V, M5H		
	Programmable controller, relay		For programmable controller, relay, IC circuit (without indicator lamp), serial connection		
Applications	-		-		
Power supply voltage	-		-		
Load voltage	12/24 VDC	110 VAC	5/12/24 VDC		110 VAC or less
Load current	5 to 50 mA	7 to 20 mA	50 mA or less		20 mA or less
Indicator lamp	LED (Lit when ON)		Without indicator lamp		
Leakage current	0 mA				
Weight	g 1 m:22 3 m:57 5 m:93				

*1: Refer to Ending Page 1 for detailed switch specifications and dimensions.

Switch specifications (T type switch)

- 2-color display

Item	Proximity 2-wire		Proximity 3-wire	
	T2YH/T2YV	T2WH/T2WV	T3YH/T3YV	T3WH/T3WV
Applications	Dedicated for programmable controller		For programmable controller, relay	
Output method	-		NPN output	NPN output
Power supply voltage	-		10 to 28 VDC	
Load voltage	10 to 30 VDC	24 VDC ±10%	30 VDC or less	
Load current	5 to 20 mA (*3)		50 mA or less	
Indicator lamp	Red/green LED (Lit when ON)	Red/green LED (Lit when ON)	Red/green LED (Lit when ON)	Red/green LED (Lit when ON)
Leakage current	1 mA or less		10 µA or less	
Weight	g 1 m:33 3 m:87 5 m:142		1 m:18 3 m:49 5 m:80	

- For AC magnetic field

Item	Proximity switch	
	T2YD, T2YDT	(*4)
Applications	Dedicated for programmable controller	
Indicator lamp	Red/green LED (Lit when ON)	
Load voltage	24 VDC ±10%	
Load current	5 to 20 mA	
Internal voltage drop	6V or less	
Leakage current	1.0 mA or less	
Weight	g 1 m:61 3 m:166 5 m:272	

*1: Refer to Ending Page 1 for detailed switch specifications and dimensions.

*2: Switches other than the above models, such as switches with connectors, are also available. Refer to Ending Page 1.

*3: The max. load current is 20 mA at 25°C. The current is lower than 20 mA if the operating ambient temperature around the switch is higher than 25°C.
(5 to 10 mA at 60°C)

*4: AC magnetic field proof switch (T2YD/T2YDT) cannot be used in DC magnetic field.

Cylinder weight

Unit: kg

Bore size (mm)	Weight for 0 mm stroke length		Mounting bracket weight		Additional weight per St = 100 mm	
	Basic (00)	Foot (LB)	T type	M type		
ø12 or equiv.	0.83	0.84	Refer to the weight in the switch specifications.	0.005	0.001	0.18
ø16 or equiv.	0.95	0.96				0.21
ø20 or equiv.	1.17	1.19				0.26
ø25 or equiv.	2.24	2.34				0.43
ø32 or equiv.	3.8	3.9				0.54
ø40 or equiv.	5.0	5.1				0.71
ø50 or equiv.	7.4	7.5				0.96
ø63 or equiv.	12.4	12.7				1.46

SRT3 Series

How to order

Without switch (built-in magnet for switch)

SRT3-00-32B-200 ————— **Y**

With switch (built-in magnet for switch)

SRT3-00-32B-200-M0H-R-Y

A Mounting
*1

B Bore size

C Cushion

D Stroke length

E Switch model No.
*3, *4

F Switch quantity

G Option

⚠ Precautions for model No. selection

*1 : Mounting bracket will be shipped assembled with the product.

*2 : Refer to page 1706 for the min. stroke length with switch.

*3 : Switches other than **E** Switch model No. are also available. (Made to order) Refer to Ending Page 1 for details.

*4 : Avoid environments where the cylinder is exposed to welding spatters. Be careful with T2YD and T2YDT in use.

[Example of model No.]

SRT3-00-32B-200-M0H-R-Y

Model: Rodless cylinder with brake

- A** Mounting : Basic
- B** Bore size : ø32 mm
- C** Cushion : Both sides cushioned
- D** Stroke length : 200 mm
- E** Switch model No. : Reed M0H switch
- F** Switch quantity : 1 on R side
- G** Option : Floating fitting

Code	Description
A Mounting	
00	Basic
LB	Axial foot

B Bore size (mm)	
12	ø12 or equiv.
16	ø16 or equiv.
20	ø20 or equiv.
25	ø25 or equiv.
32	ø32 or equiv.
40	ø40 or equiv.
50	ø50 or equiv.
63	ø63 or equiv.

C Cushion	
B	Both sides cushioned
R	R side cushioned
L	L side cushioned
N	Without cushion

D Stroke length (mm)		
Bore size	Stroke length (*2)	Custom stroke length
ø12 to ø20	1 to 1000	In 1 mm increments
ø25 to ø40	1 to 1500	
ø50, ø63	1 to 2000	

E Switch model No.						
Axial lead wire	Radial lead wire	Reed/Contact	Voltage		Indicator lamp	Lead wire
			AC	DC		
M0H*	M0V*	●	●		1-color display	2-wire
M5H*	M5V*				Without indicator lamp	
M2H*	M2V*	●			1-color display	2-wire
-	M2WV*				2-color display	
M3H*	M3V*	●			1-color display	3-wire
-	M3WV*				2-color display	
M3PH*	M3PV*	●			1-color display (custom)	3-wire
T2WH*	T2WV*				Proximity	
T2YH*	T2YV*					
T3WH*	T3WV*					
T3YH*	T3YV*					
T2YD*	-	●			2-color display	2-wire
T2YDT*	-				AC magnetic field	

* Lead wire length	
Blank	1 m (standard)
3	3 m (option)
5	5 m (option)

F Switch quantity	
R	1 on R side
L	1 on L side
D	2
T	3
4	4 (when there are more than 4 switches, indicate switch quantity.)

G Option	
Y	Floating fitting

How to order switch

Switch body + mounting bracket set (*1)

SRL3 - M0H

Switch model No.
(Item **E** on page 1708)

Switch body only

SW - M0H

Switch model No.
(Item **E** on page 1708)

Mounting bracket set (*2)

· M type switch

SRL3 - M

· T type switch

SRL3 - T

Lead wire holder (*3)

SRL3 - MH

* Lead wire length

Blank	1 m (standard)
3	3 m (option)
5	5 m (option)

(*1) "Switch body + mounting bracket set" does not include lead wire holders.

Order lead wire holders separately if necessary.

(*2) The mounting bracket is different between the M type switch and T type switch.

(*3) The quantity of lead wire holders per set is 10.

How to order repair parts

SRL3 - 40 K - 200

Bore size
(Item **B** on page 1708)

Stroke length
(Item **D** on page 1708)

Note: The switch mounting bracket, floating fitting and repair parts are common with those of SRL3.

How to order floating fitting set

SRL3 - 40 - Y

Bore size
(Item **B** on page 1708)

(Mount, mount base, pin, plain washer, pan head machine screw with spring washer, four mounting bolts)

How to order mounting bracket

SRT3 - LB - 40

(Bracket x2, mounting bolt x4)

Bore size
(Item **B** on page 1708)

Theoretical thrust table

(Unit: N)

Bore size (mm)	Operating direction	Working pressure MPa							
		0.1	0.15	0.2	0.3	0.4	0.5	0.6	0.7
ø12	Push/Pull	-	-	27.7	41.5	55.3	69.1	83.0	96.8
ø16	Push/Pull	-	-	43.2	64.8	86.4	1.08×10^2	1.30×10^2	1.51×10^2
ø20	Push/Pull	-	-	62.9	94.4	1.26×10^2	1.57×10^2	1.89×10^2	2.20×10^2
ø25	Push/Pull	-	81.4	1.08×10^2	1.63×10^2	2.17×10^2	2.71×10^2	3.25×10^2	3.80×10^2
ø32	Push/Pull	-	1.22×10^2	1.63×10^2	2.44×10^2	3.26×10^2	4.07×10^2	4.88×10^2	5.70×10^2
ø40	Push/Pull	-	1.90×10^2	2.53×10^2	3.80×10^2	5.06×10^2	6.33×10^2	7.60×10^2	8.86×10^2
ø50	Push/Pull	1.99×10^2	2.98×10^2	3.98×10^2	5.96×10^2	7.95×10^2	9.94×10^2	1.19×10^3	1.39×10^3
ø63	Push/Pull	3.14×10^2	4.70×10^2	6.27×10^2	9.41×10^2	1.25×10^3	1.57×10^3	1.88×10^3	2.20×10^3

SCP*3

Internal structure and parts list (ø12 to ø63)

CMK2

The internal structure of cylinder is SRL3. Refer to pages 1579 and 1580.

CMA2

SCM

SCG

SCA2

SCS2

CKV2

CAV2/

COVPIN2

SSD2

SSG

SSD

CAT

MDC2

MVC

SMG

MSD/

MSDG

FC*

STK

SRL3

SRG3

SRM3

SRT3

MRL2

MRG2

SM-25

ShkAbs

FJ

FK

Spd

Contr

Ending

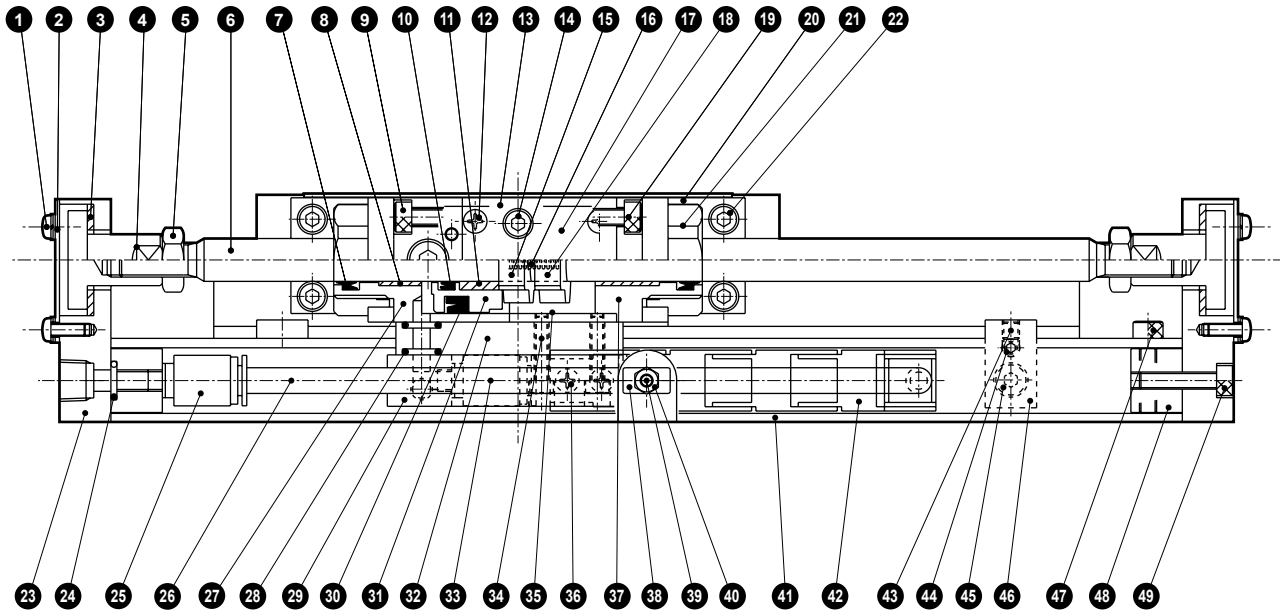

Brake section cannot be disassembled

Parts list

No.	Part name	Material	Remarks	No.	Part name	Material	Remarks
1	Pan head machine screw	Steel	Zinc chromate	27	Body A	Aluminum alloy	Alumite
2	Fitting cover	Aluminum alloy	Alumite	28	Gasket	Nitrile rubber	
3	Slide plate	Dry bearing		29	Adaptor	Aluminum alloy	Alumite
4	Floating fitting	Steel	Manganese phosphate treatment	30	Piston packing	Nitrile rubber	
5	Hexagon nut, three types	Steel	Zinc chromate	31	Release piston	Aluminum alloy	Alumite
6	Brake shaft	Steel	Industrial chrome plating	32	Spacer	Aluminum alloy	Alumite
7	Rod packing	Nitrile rubber		33	Push-in fitting		
8	Bearing bush	Dry bearing		34	Hexagon socket head cap screw	Steel	Black finish
9	Hexagon socket head cap screw	Steel	Black finish	35	Body B	Aluminum alloy	Alumite
10	Rod packing	Nitrile rubber		36	Pan head machine screw	Steel	Zinc chromate
11	Bearing bush	Copper-based		37	Brake end cover	Aluminum alloy	Alumite
12	Pan head machine screw	Steel	Zinc chromate	38	Square nut	Steel	Zinc chromate
13	Brake mounting base	Aluminum alloy	Alumite	39	Pan head machine screw	Steel	Zinc chromate
14	Hexagon socket head cap screw	Steel	Black finish	40	Hexagon nut, three types	Steel	Zinc chromate
15	Brake plate A	Special steel	Zinc chromate	41	Cable holder	Aluminum alloy	Alumite
16	Brake spring	Steel	Black finish	42	Cableveyor	Special resin	
17	Cover	Aluminum alloy	Alumite	43	ø12 to ø40: Hexagon socket set screw ø50, ø63: -	Steel	Black finish
18	Brake plate B	Special steel	Zinc chromate	44	ø12 to ø40: Hexagon socket set screw ø50, ø63: Hexagon socket button head bolt	Steel	Black finish
19	Hexagon socket head cap screw	Steel	Black finish	45	Hexagon socket button head bolt	Steel	Black finish
20	Brake mounting foot	Steel	Zinc chromate	46	Rail stop plate	Steel	Zinc chromate
21	Fixing nut	Steel	Zinc chromate	47	Hexagon socket head cap screw	Steel	Black finish
22	Hexagon socket head cap screw	Steel	Black finish	48	Cable holder stopper	Aluminum alloy	Alumite
23	End flange	Aluminum alloy	Alumite	49	Hexagon socket head cap screw	Steel	Black finish
24	Gasket	Nitrile rubber					
25	Push-in fitting						
26	Tube	Polyamide					

MEMO

SCP*3

CMK2

CMA2

SCM

SCG

SCA2

SCS2

CKV2

CAV2/
COVP/N2

SSD2

SSG

SSD

CAT

MDC2

MVC

SMG

MSD/
MSDG

FC*

STK

SRL3

SRG3

SRM3

SRT3

MRL2

MRG2

SM-25

ShkAbs

FJ

FK

Spd
Contr

Ending

SRT3 Series



Dimensions (bore size: $\varnothing 12$, $\varnothing 16$, mounting: 00)

● With cylinder switch SRT3-00-**-***-M*V* (lead wire L-shaped)

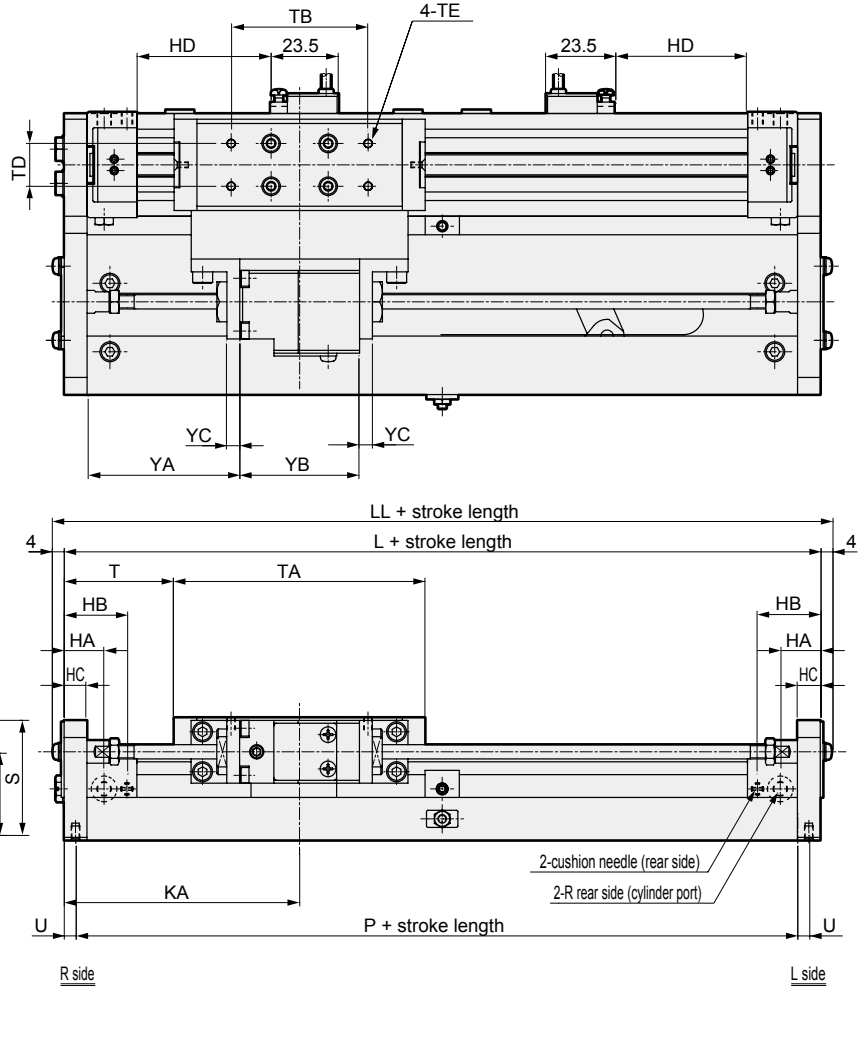

RD: Max. sensitivity installation position HD: Max. sensitivity installation position

Code	A	B	C	D	DC	DD	F	G	H	HA	HB	HC	I	J	KA	L	LL	M	N	O	P	Q	R	S
Bore size (mm)																								
$\varnothing 12$ or equiv.	94.5	16.5	39	16	11	16.5	16.5	70	46	14	22	8	27	27.5	76	152	160	M3 depth 5	M3 depth 6	8	144	M5	M5	39
$\varnothing 16$ or equiv.	98.5	18	43	20	12	18	18.5	72	48	14	22	8	30	31	82.5	165	173	M3 depth 5	M3 depth 6	8	157	M5	M5	42

Code	T	TA	TB	TC	TD	TE	TG	U	W	XF	YA	YB	YC
Bore size (mm)													
$\varnothing 12$ or equiv.	35.5	81	42	29	13	M3 depth 5	8	4	5	99.5	47	42	415
$\varnothing 16$ or equiv.	38.5	88	48	32	15	M3 depth 5	12	4	5	99.5	53.5	42	415

Code	With switch																
	HD			RD			PA	PB			PP2						
Bore size (mm)	M*	T*Y*	T*W	M*	T*Y*	T*W		T*Y*	T2YD	T*W*	M*V	M*H	T*YV	T*YH	T2YD	T*WV	T*WH
$\varnothing 12$ or equiv.	40.5	36	32	60.5	65	69	24.3	35	34	33.5	24.5	23	26	23	28.4	20.7	17.2
$\varnothing 16$ or equiv.	47	42	38	67	72	76	26.3	35	34	33.5	26.5	25	28	25	30.4	22.7	19.2

Dimensions (bore size: $\varnothing 12$, $\varnothing 16$, mounting: 00)

- With cylinder switch SRT3-00-**-***-M*H* (lead wire straight)

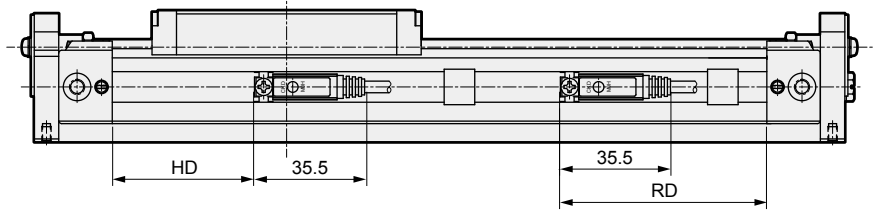
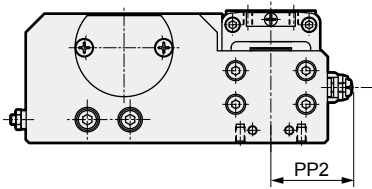

- With cylinder switch SRT3-00-**-***-T*H (T*W, T*Y, T2YD)

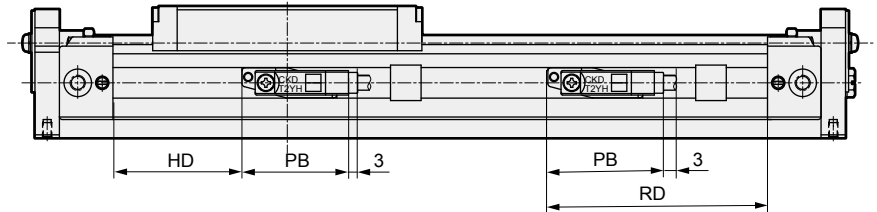
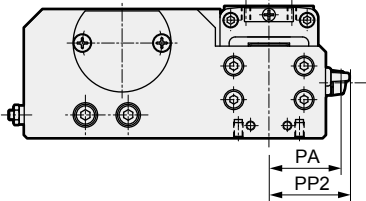

- With cylinder switch SRT3-00-**-***-T*V (T*W, T*Y)

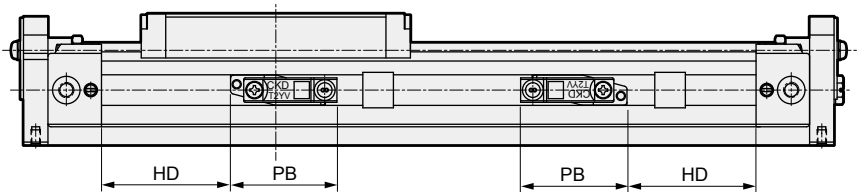
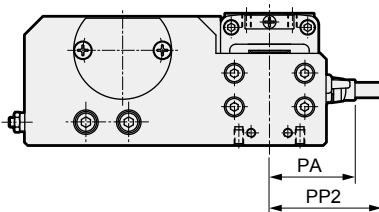

SCP*3

CMK2

CMA2

SCM

SCG

SCA2

SCS2

CKV2

CAV2/
COVP/N2

SSD2

SSG

SSD

CAT

MDC2

MVC

SMG

MSD/
MSDG

FC*

STK

SRL3

SRG3

SRM3

SRT3

MRL2

MRG2

SM-25

ShkAbs

FJ

FK

Spd
Contr

Ending

Dimensions (bore size: $\varnothing 20$, mounting: 00)

● With cylinder switch SRT3-00-20-***-M*V* (lead wire L-shaped)

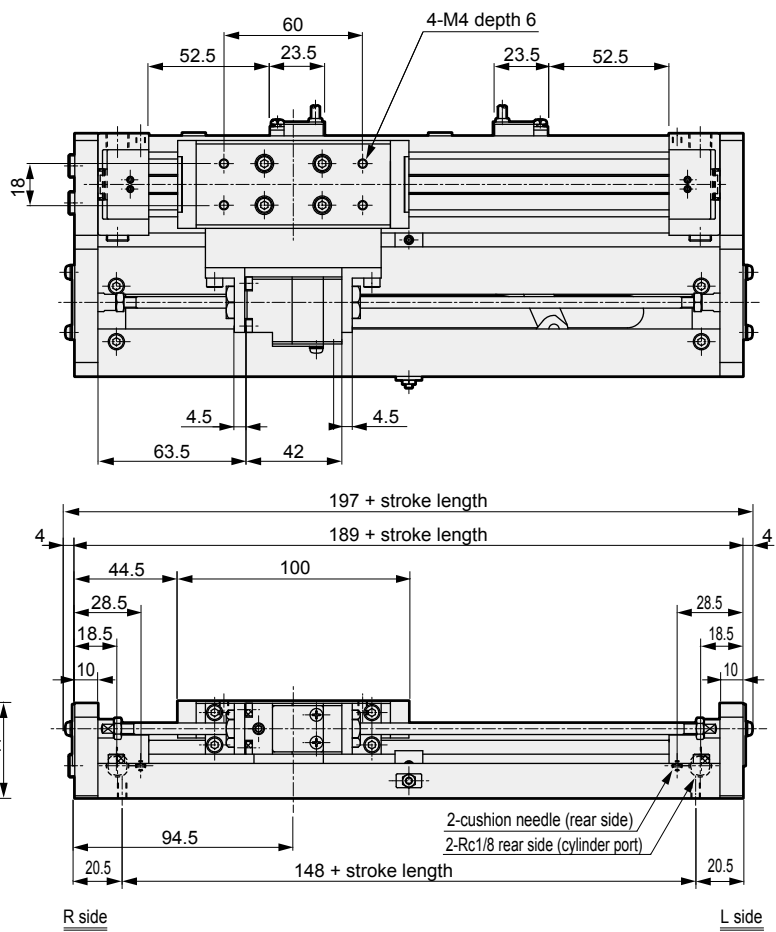
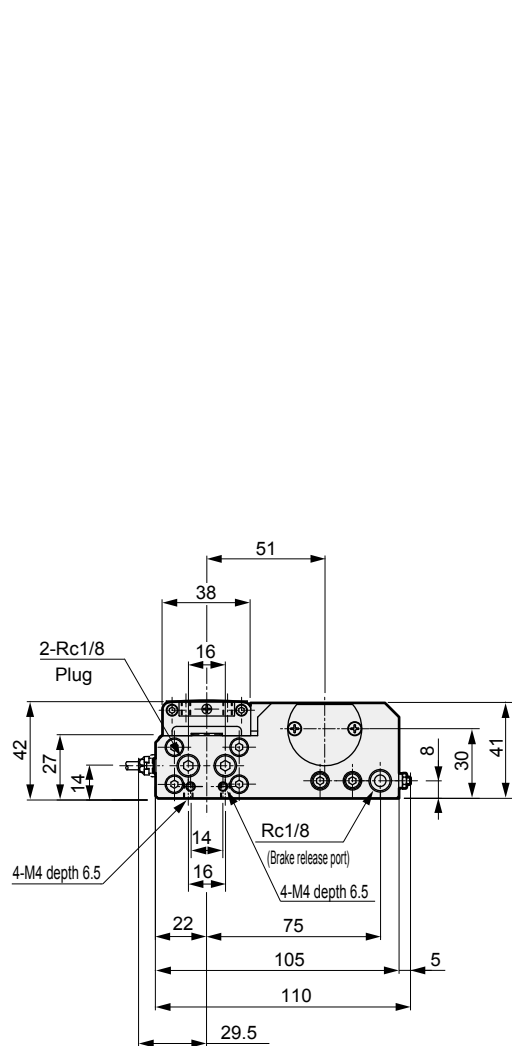

● With cylinder switch SRT3-00-20-***-M*H* (lead wire straight)

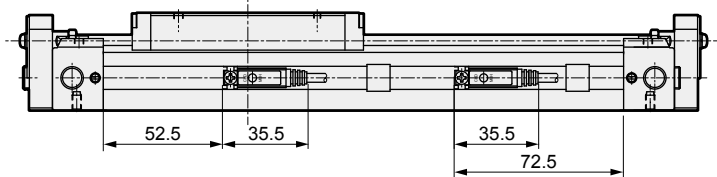
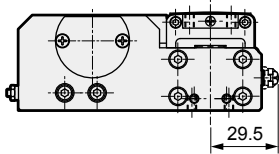

● With cylinder switch SRT3-00-20-***-T*H (T*W, T*Y, T2YD)

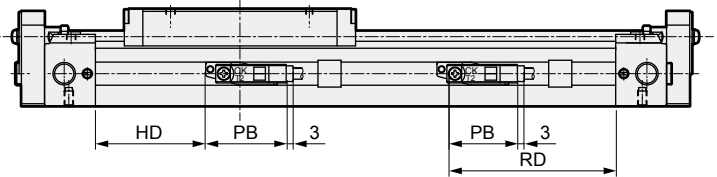
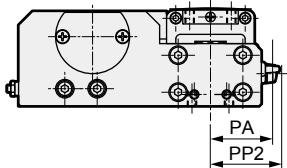

● With cylinder switch SRT3-00-20-***-T*V (T*W, T*Y)

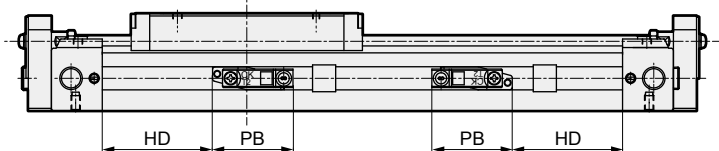
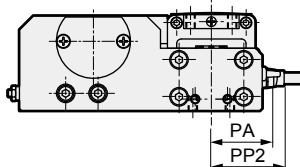

Dimensions (bore size: $\varnothing 25$, mounting: 00)

- With cylinder switch SRT3-00-25-***-M*V* (lead wire L-shaped)

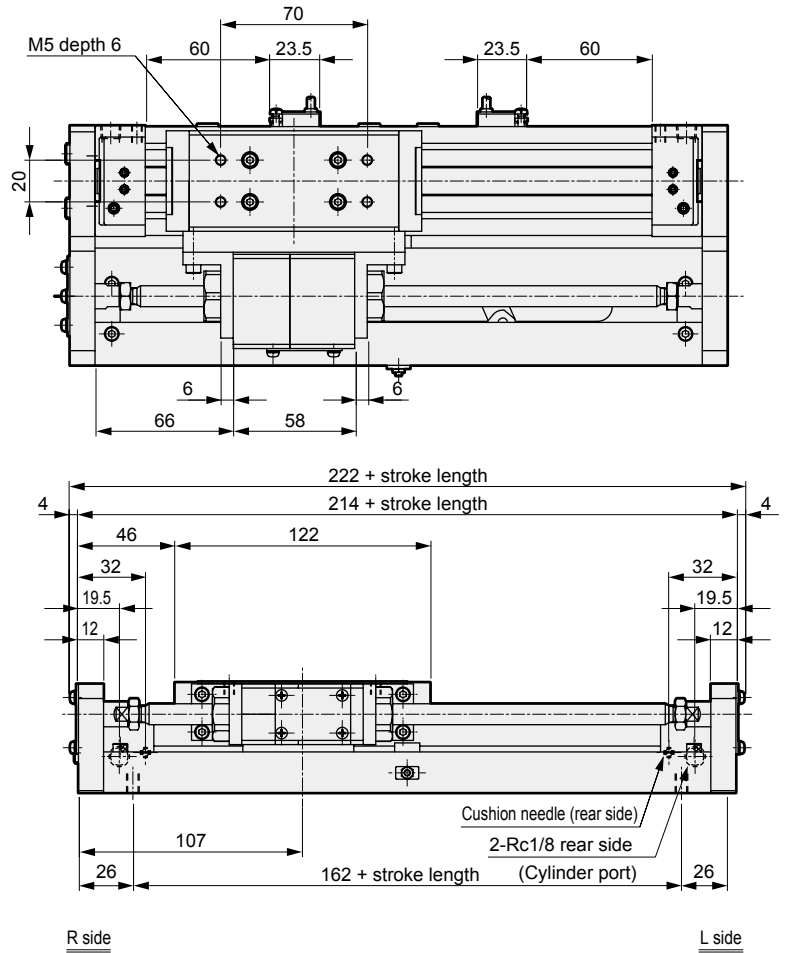

- With cylinder switch SRT3-00-25-***-M*H* (lead wire straight)

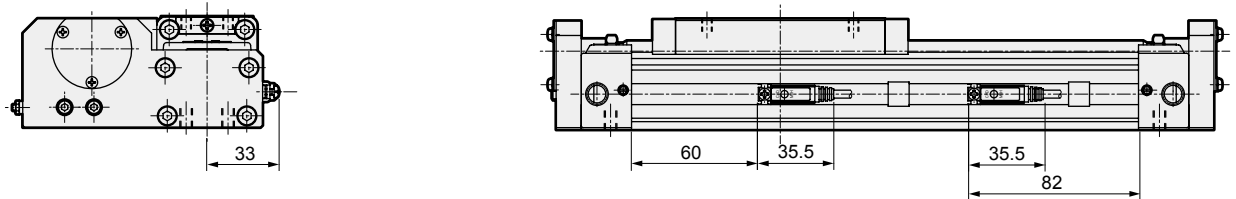

- With cylinder switch SRT3-00-25-***-T*H (T*W, T*Y, T2YD)

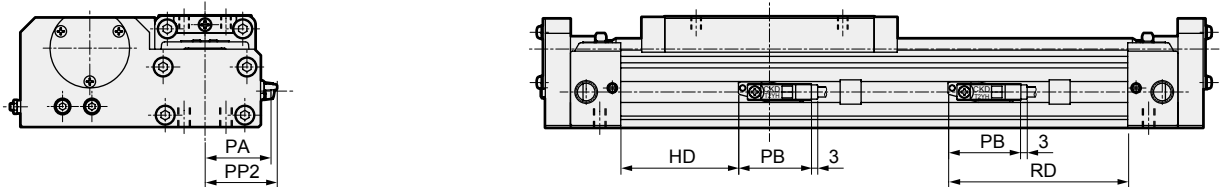

- With cylinder switch SRT3-00-25-***-T*V (T*W, T*Y)

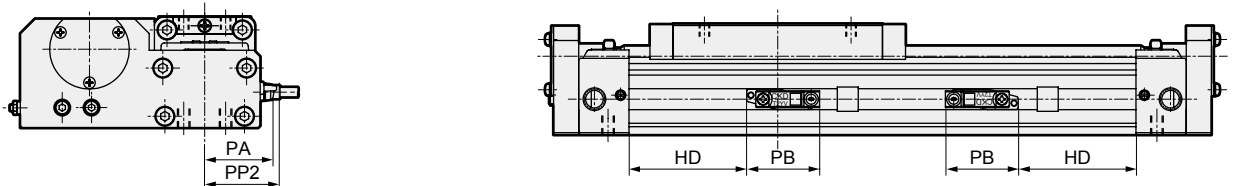

SCP*3
CMK2
CMA2
SCM
SCG
SCA2
SCS2
CKV2
CAV2/ COVP/N2
SSD2
SSG
SSD
CAT
MDC2
MVC
SMG
MSD/ MSDG
FC*
STK
SRL3
SRG3
SRM3
SRT3
MRL2
MRG2
SM-25
ShkAbs
FJ
FK
Spd Contr
Ending



Dimensions (bore size: $\varnothing 32$ to $\varnothing 63$, mounting: 00)

● With cylinder switch SRT3-00-**-***-M*V* (lead wire L-shaped)

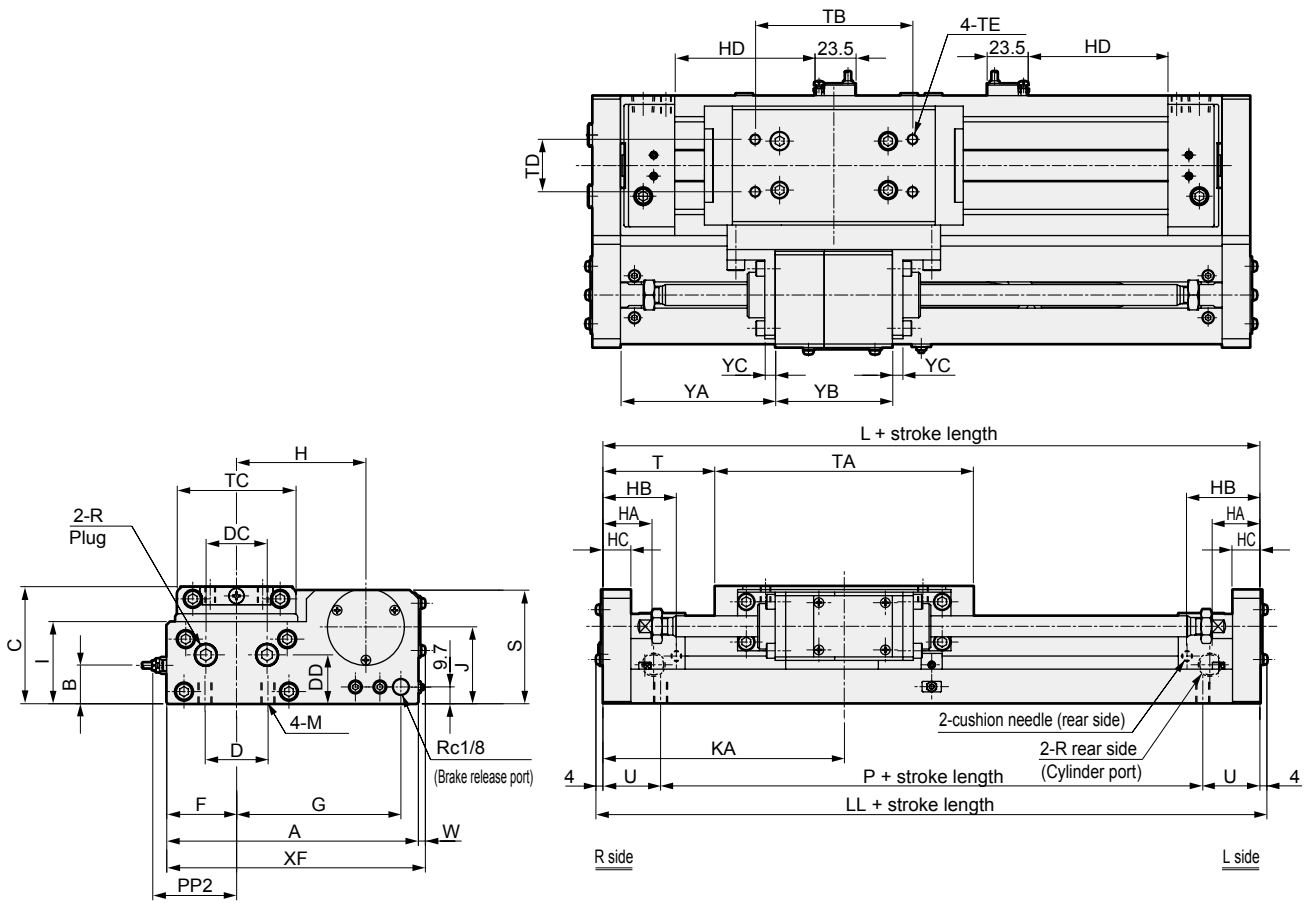

RD: Max. sensitivity installation position HD: Max. sensitivity installation position

Code	A	B	C	D	DC	DD	F	G	H	HA	HB	HC	I	J	KA	L	LL	M	P	R	S	T	
SRT3 Bore size (mm)																							
$\varnothing 32$ or equiv.	129	18.5	57	32	27	21	33	87	66	24	37.5	14	39	39	127	254	262	M6 depth 9	196	Rc 1/4	56	60	
$\varnothing 40$ or equiv.	144	22	67	36	35	28	40	94	74	29	42	16	47	44	138	276	284	M8 depth 12	210	Rc 1/4	65	64	
$\varnothing 50$ or equiv.	177	28	82	45	35	35	48	102	89	33	51	18	57	52	147	294	302	M8 depth 12	212	Rc 3/8	77	71	
$\varnothing 63$ or equiv.	209	35	95	50	39	42	59	113	105	35	52	20	68	60	168	336	344	M10 depth 15	258	Rc 3/8	93	84	

Code	TA	TB	TC	TD	TE	U	W	XF	YA	YB	YC
MRG2 Bore size (mm)											
$\varnothing 32$ or equiv.	134	80	56	20	M6 depth 7.5	29	4	133	78.5	69	6
$\varnothing 40$ or equiv.	148	90	68	30	M6 depth 9	33	4	148	88.5	67	6
$\varnothing 50$ or equiv.	152	100	80	30	M8 depth 10.5	41	4	181	92.5	73	8
$\varnothing 63$ or equiv.	168	110	102	40	M8 depth 11.5	39	1	210	98.5	99	9

Code	With switch																
	HD			RD			PA	PB			PP2						
	M*	T*Y*	T*W	M*	T*Y*	T*W		T*Y*	T2YD	T*W*	M*V	M*H	T*YV	T*YH	T2YD	T*WV	T*WH
$\varnothing 32$ or equiv.	74	70	66	96	100	104	41.3	35	34	33.5	41.5	40	43	40	45.4	37.7	34.2
$\varnothing 40$ or equiv.	80	76	72	102	106	110	48.3	35	34	33.5	48.5	47	50	47	52.4	44.7	41.2
$\varnothing 50$ or equiv.	79	75	71	101	105	109	56.3	35	34	33.5	56.5	55	58	55	60.4	52.7	49.2
$\varnothing 63$ or equiv.	98	94	90	120	124	128	67.3	35	34	33.5	67.5	66	69	66	71.4	63.7	60.2

Dimensions (bore size: $\varnothing 32$ to $\varnothing 63$, mounting: 00)

- With cylinder switch SRT3-00-**-***-M*H* (lead wire straight)

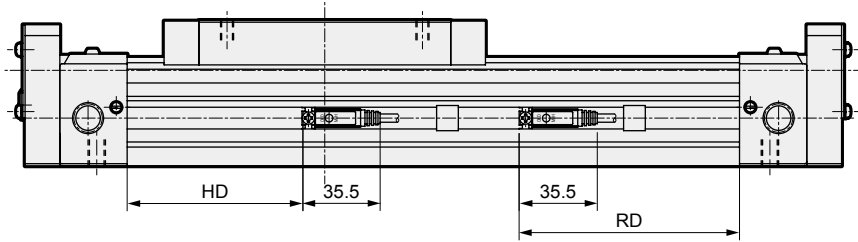
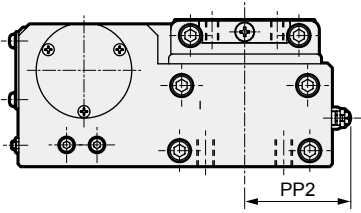

- With cylinder switch SRT3-00-**-***-T*H (T*W, T*Y, T2YD)

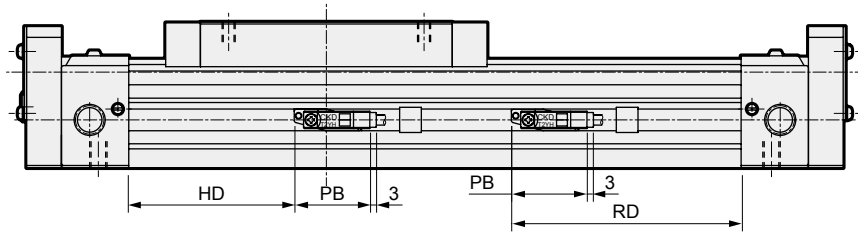
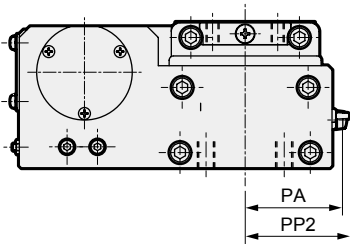

- With cylinder switch SRT3-00-**-***-T*V (T*W, T*Y)

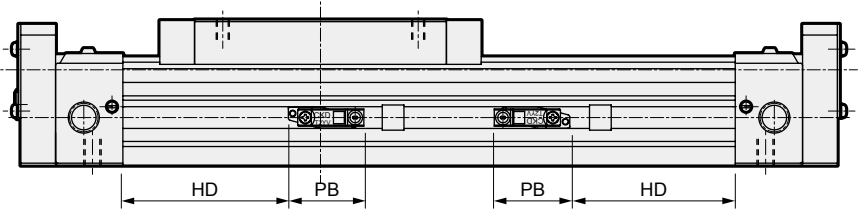
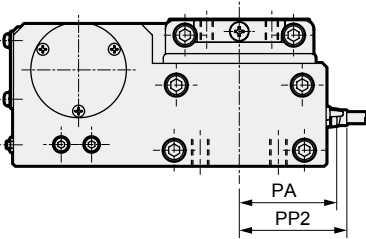

SCP*3
CMK2
CMA2
SCM
SCG
SCA2
SCS2
CKV2
CAV2/ COVP/IN2
SSD2
SSG
SSD
CAT
MDC2
MVC
SMG
MSD/ MSDG
FC*
STK
SRL3
SRG3
SRM3
SRT3
MRL2
MRG2
SM-25
ShkAbs
FJ
FK
Spd Contr
Ending

- SCP*3
- CMK2
- CMA2
- SCM
- SCG
- SCA2
- SCS2
- CKV2
- CAV2/
COVPIN2
- SSD2
- SSG
- SSD
- CAT
- MDC2
- MVC
- SMG
- MSD/
MSDG
- FC*
- STK
- SRL3
- SRG3
- SRM3
- SRT3**
- MRL2
- MRG2
- SM-25
- ShkAbs
- FJ
- FK
- Spd
Contr
- Ending

Dimensions (bore size: $\varnothing 12$, $\varnothing 16$, mounting: LB)



● With foot bracket SRT3-LB-**-***

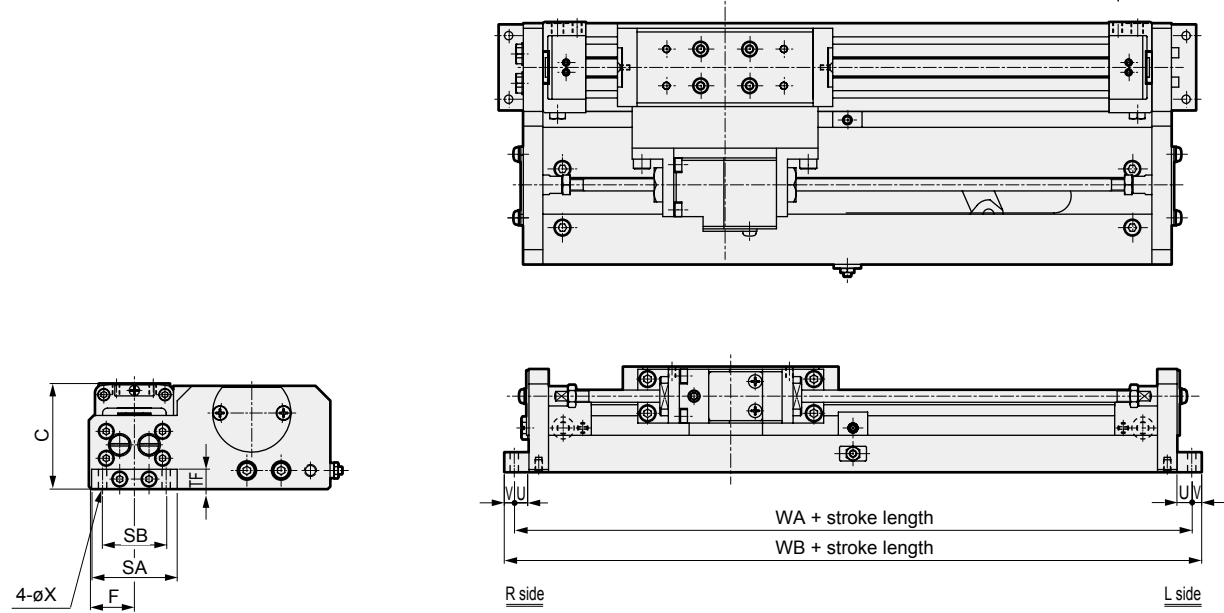

Code	C	F	Mounting method							
			SA	SB	TF	U	V	X	WA	WB
$\varnothing 12$ or equiv.	39	16.5	32	24	8	6	4	3.4	164	172
$\varnothing 16$ or equiv.	43	18.5	35	26	8	6	4	3.4	177	185

Dimensions (bore size: $\varnothing 20$, mounting: LB)



● With foot bracket SRT3-LB-20-***

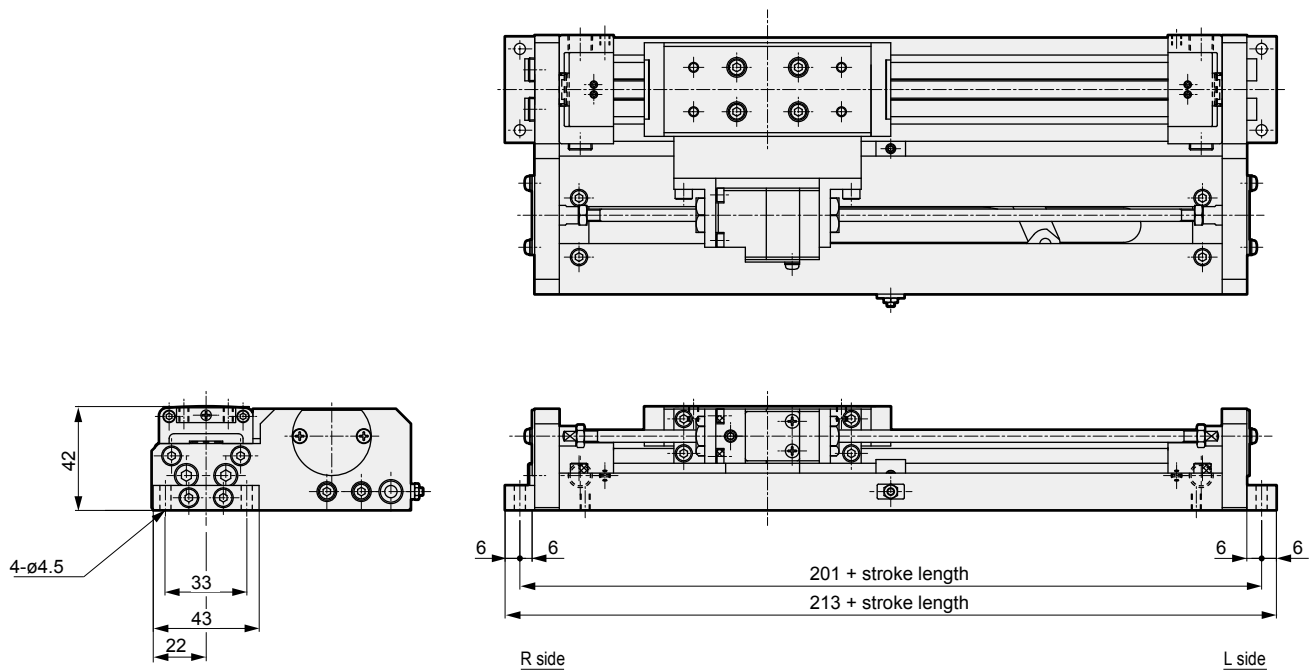

Dimensions (bore size: $\varnothing 25$, mounting: LB)



● With foot bracket SRT3-LB-25-***

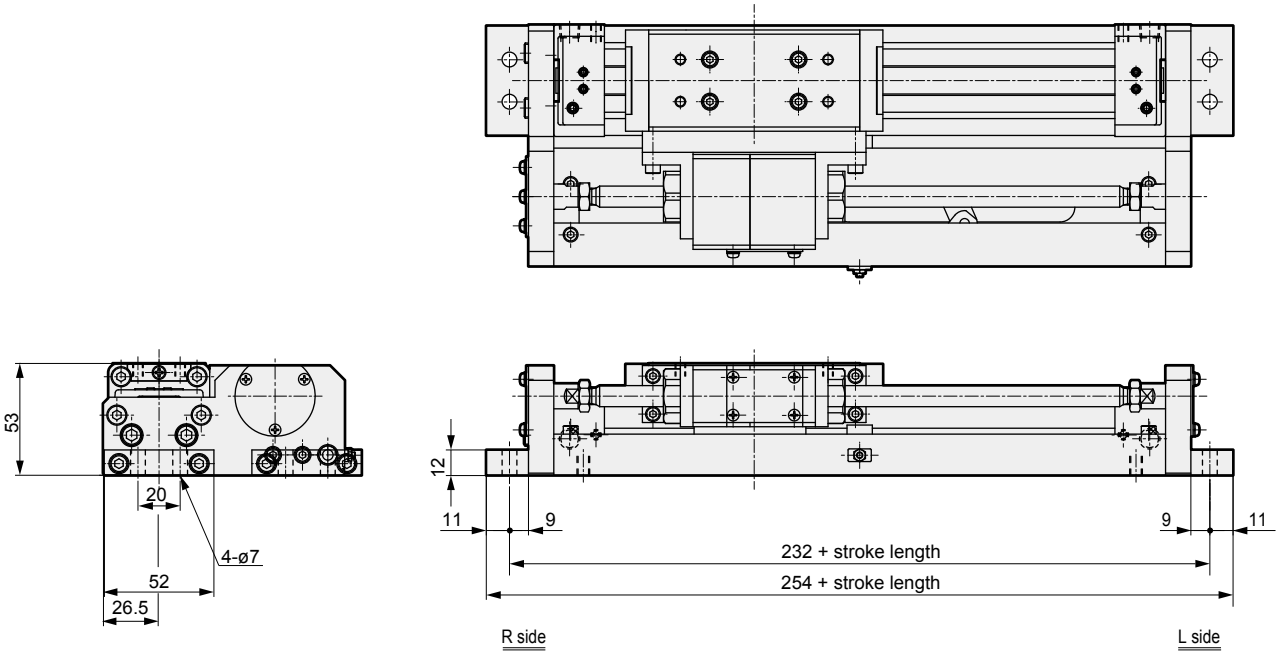

Dimensions (bore size: $\varnothing 32$ to $\varnothing 63$, mounting: LB)



● With foot bracket SRT3-LB-**-***

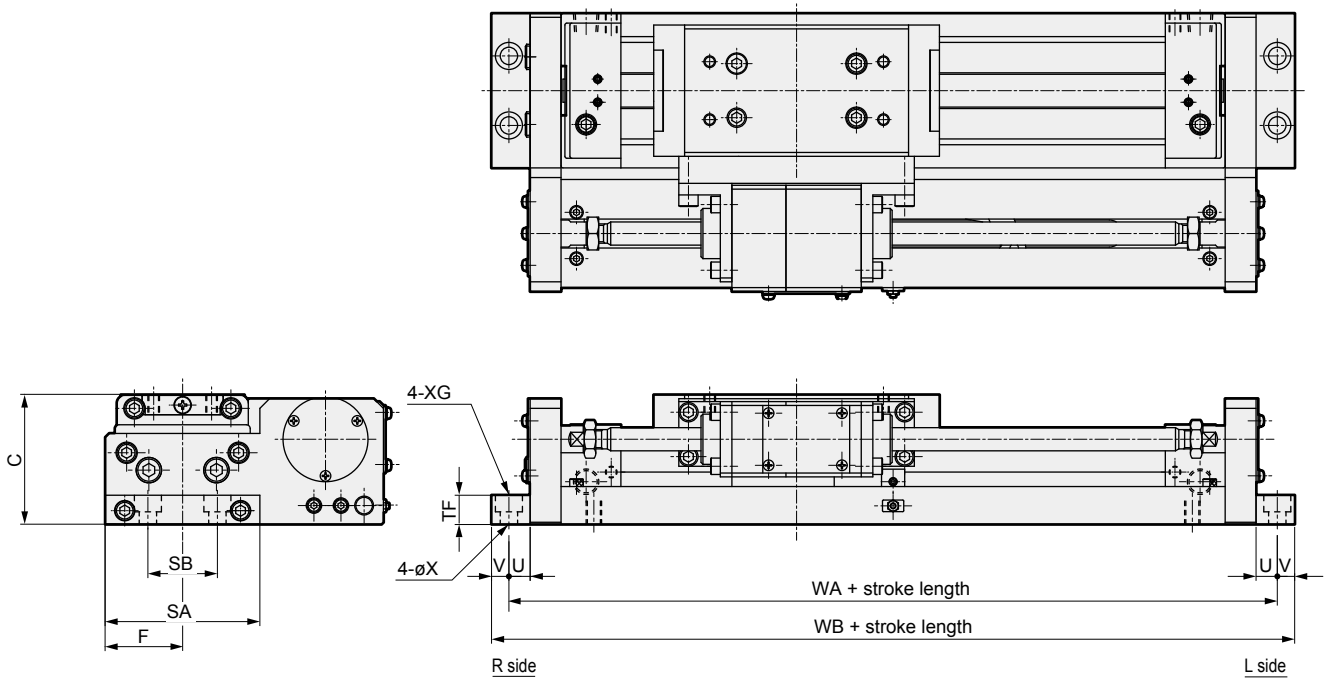

RD: Max. sensitivity installation position HD: Max. sensitivity installation position

Code Bore size (mm)	C	F	Mounting method								
			SA	SB	TF	U	V	WA	WB	X	XG
$\varnothing 32$ or equiv.	57	33	64	32	12	9	11	272	294	7	-
$\varnothing 40$ or equiv.	67	40	80	36	15	11	9	298	316	9	14 spot face depth 8.6
$\varnothing 50$ or equiv.	82	48	94	45	20	11	9	316	334	9	14 spot face depth 8.6
$\varnothing 63$ or equiv.	95	59	116	50	25	13	12	362	386	11	17.5 spot face depth 10.8

SCP*3

CMK2

CMA2

SCM

SCG

SCA2

SCS2

CKV2

CAV2/
COVP/N2

SSD2

SSG

SSD

CAT

MDC2

MVC

SMG

MSD/
MSDG

FC*

STK

SRL3

SRG3

SRM3

SRT3

MRL2

MRG2

SM-25

ShkAbs

FJ

FK

Spd
Contr

Ending

Dimensions: Option



● Floating fitting

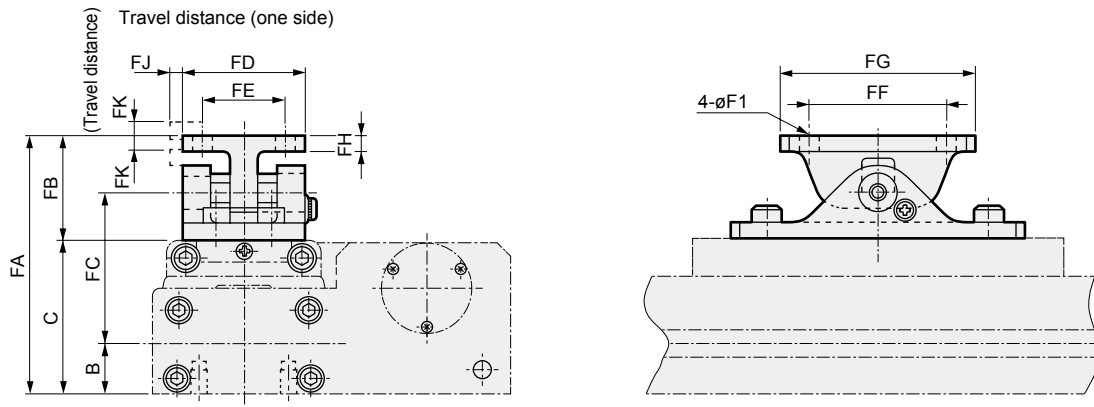

Code	FA	FB	FC	FD	FE	FF	FG	FH	FI	FJ	FK	B	C
Bore size (mm)													
ø12 or equiv.	54	21	31.5	24	16	30	40	3	3.4	3	3	10.5	33
ø16 or equiv.	58	21	34	24	16	30	40	3	3.4	3	3	12	37
ø20 or equiv.	67	25	39	30	20	40	56	4	4.5	3	3	14	42
ø25 or equiv.	78	25	47	30	20	40	56	4	6	3	3	17	53
ø32 or equiv.	95	38	55.5	45	30	50	70	6	7	5	5	18.5	57
ø40 or equiv.	105	38	62	45	30	50	70	6	7	5	5	22	67
ø50 or equiv.	126	44	73	60	40	70	90	8	9	5	5	28	82
ø63 or equiv.	139	44	79	60	40	70	90	8	9	5	5	35	95

- SCP*3
- CMK2
- CMA2
- SCM
- SCG
- SCA2
- SCS2
- CKV2
- CAV2/
COVPIN2
- SSD2
- SSG
- SSD
- CAT
- MDC2
- MVC
- SMG
- MSD/
MSDG
- FC*
- STK
- SRL3
- SRG3
- SRM3
- SRT3**
- MRL2
- MRG2
- SM-25
- ShkAbs
- FJ
- FK
- Spd
Contr
- Ending