

LCM
LCR
LCG
LCW
LCX
STM
STG
STS/STL
STR2
UCA2
ULK*
JSK/M2
JSG
JSC3/JSC4
USSD
UFCD
USC
UB
JSB3
LMB
LML
HCM
HCA
LBC
CAC4
UCAC2
CAC-N
UCAC-N
RCS2
RCC2
PCC
SHC
MCP
GLC
MFC
BBS
RRC
GRC
RV3*
NHS
HRL
LN
Hand
Chuk
MechHnd/Chuk
ShkAbs
FJ
FK
SpdContr
Ending

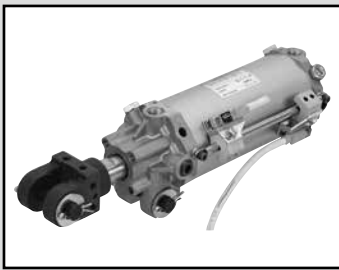

Clamp cylinder/double acting/single rod

CAC4 Series

● Bore size: $\varnothing 40/\varnothing 50/\varnothing 63/\varnothing 80$

JIS symbol



Specifications

Item	CAC4			
	Bore size mm	$\varnothing 40$	$\varnothing 50$	$\varnothing 63$
Operation	Double acting			
Working fluid	Compressed air			
Max. working pressure MPa	1.0 (≈ 150 psi, 10 bar)			
Min. working pressure MPa	0.1 (≈ 15 psi, 1 bar)			
Proof pressure MPa	1.6 (≈ 230 psi, 16 bar)			
Ambient temperature $^{\circ}\text{C}$	-10 (14°F) to 60 (140°F) (no freezing)			
Port size	Rc1/4			Rc3/8
Standard stroke length mm	50, 75, 100, 125, 150			
Working piston speed mm/s	50 to 500	50 to 400	50 to 300	
Cushion	Head side air cushioned			
Effective air cushion length mm	13.5			15.4
Lubrication	Not required (use turbine oil ISO VG32 if necessary for lubrication)			
Mounting	Clevis bracket			

* Operate within the absorbed energy. Refer to table below.

Stroke length

Bore size (mm)	Standard stroke length (mm)	Max. stroke length (mm)	Min. stroke length (mm)	Min. stroke with switch (mm)
$\varnothing 40$	50, 75	150	50	50
$\varnothing 50$	100, 125			
$\varnothing 63$	150			
$\varnothing 80$				

Note: Products other than standard stroke length are made-to-order products.

Cushion characteristics table

Bore size (mm)	Effective cushion length (mm)	Allowable energy (J)	
		With cushion	Without cushion
$\varnothing 40$	13.5	5.14	0.137
$\varnothing 50$	13.5	6.41	0.137
$\varnothing 63$	13.5	11.37	0.205
$\varnothing 80$	15.4	25.4	0.360

● Cushion

The purpose of the cushion is to absorb the piston's kinetic energy with air compressibility, preventing the piston and collar from colliding at the stroke end. Therefore, the cushion itself does not reduce the piston speed at the stroke end.

Note that the left table shows the kinetic energy which can be absorbed by the cushion. If the kinetic energy exceeds these values, or if bouncing caused by the air compressibility is to be avoided, consider using another shock absorber.

$$\text{Kinetic energy (J)} = \frac{1}{2} \times \text{load weight (kg)} \times [\text{speed (m/s)}]^2$$

Cylinder weight

(Unit: kg)

Bore size (mm)	Product weight per 0 mm stroke length	Additional weight per 100 mm stroke length	Accessory weight					Switch Weight	Mounting bracket weight		Weight of tie rod at 0 mm stroke length	Additional weight of tie rod per S = 10 mm	
			Axial foot	Rod clevis	Rod eye	Limit switch mounting base	Dog bracket		T type				
									Tie rod mount	Band mount			H type
$\varnothing 40$	0.75	0.34	0.21	0.37	0.27	0.18	0.08	Refer to the weight in the switch specifications.	0.021	0.007	0.024	0.019	0.003
$\varnothing 50$	0.82	0.36								0.008			
$\varnothing 63$	1.03	0.39								0.009			
$\varnothing 80$	2.80	0.60	-	0.010	0.030								

(Example) Product weight of CAC4-A-40-150-Y

- Product weight for stroke length 0 mm 0.75 kg
- Additional weight for stroke length 150 mm $0.34 \times \frac{150}{100} = 0.51$ kg
- Accessory weight (rod clevis) 0.37 kg
- Product weight $0.75 + 0.51 + 0.37 = 1.63$ kg

Switch specifications

● 1-color/2-color display

Item	Proximity 2-wire	Proximity 2-wire				Proximity 3-wire				Reed 2-wire						
	T1H/T1V	T2H/T2V/ T2JH/T2JV	T2YH/ T2YV	T2WH/ T2WV	T3H/T3V	T3PH/ T3PV	T3YH/ T3YV	T3WH/ T3WV	T0H/T0V		T5H/T5V		T8H/T8V			
Applications	For programmable controller, relay, compact solenoid valve	Dedicated for programmable controller				For programmable controller, relay				For programmable controller, relay		For programmable controller, relay, IC circuit (no indicator lamp), serial connection		For programmable controller, relay		
Output method	-				NPN output	PNP output	NPN output	NPN output	-							
Pwr. supp. V.	-				10 to 28 VDC				-							
Load voltage	85 to 265 VAC	10 to 30 VDC		24 VDC ±10%	30 VDC or less				12/24 VDC	110 VAC	5/12/24 VDC	100/110 VAC	12/24 VDC	110 VAC	220 VAC	
Load current	5 to 100 mA	5 to 20 mA (*3)				100 mA or less		50 mA or less		5 to 50 mA	7 to 20 mA	50 mA or less	20 mA or less	5 to 50 mA	7 to 20 mA	7 to 10 mA
Indicator lamp	LED (Lit when ON)	LED (Lit when ON)	Red/green LED (Lit when ON)	Red/green LED (Lit when ON)	LED (Lit when ON)	Yellow LED (Lit when ON)	Red/green LED (Lit when ON)	Red/green LED (Lit when ON)	LED (Lit when ON)		Without indicator lamp		LED (Lit when ON)			
Leakage current	≤ 1 mA at 100 VAC, ≤ 2 mA at 200 VAC	1 mA or less				10 µA or less				0 mA						
Weight g	1 m:33 3 m:87 5 m:142	1 m:18 3 m:49 5 m:80	1 m:33 3 m:87 5 m:142	1 m:18 3 m:49 5 m:80	1 m:18 3 m:49 5 m:80	1 m:33 3 m:87 5 m:142	1 m:18 3 m:49 5 m:80	1 m:18 3 m:49 5 m:80		1 m:18 3 m:49 5 m:80			1 m:33 3 m:87 5 m:142			

*1 : Refer to Ending Page 1 for detailed switch specifications and dimensions.

*2 : Switches other than the above models, such as switches with connectors, are also available. Refer to Ending Page 1.

*3 : The max. load current is 20 mA at 25°C. The current is lower than 20 mA if the operating ambient temperature around the switch is higher than 25°C.
(5 to 10 mA at 60°C)

● For AC magnetic field

Item	Proximity 2-wire		Reed 2-wire			
	T2YD, T2YDT (*4)		T2YDU (Made to order)	HO		HOY (2-color display)
Applications	Dedicated for programmable controller			For programmable controller, relay		Dedicated for programmable controller
Indicator lamp	Red/green LED (Lit when ON)			Green LED (Lit when ON)		Red/green LED (Lit when ON)
Load voltage	24 VDC ±10%			12/24 VDC	110 VAC	24 VDC
Load current	5 to 20 mA			5 to 50 mA	7 to 20 mA	5 to 20 mA (*1)
Internal voltage drop	6V or less			5V or less		6V or less
Leakage current	1.0 mA or less			10 µA or less		10 µA or less
Output delay time *1 (ON Delay, OFF delay)	60 ms or less			-		
Lead wire length	1 m (oil resistant vinyl cabtyre cable ø 6, 0.5 mm ² x 2-conductor) *2, *3		0.3 m (flame-resistant cabtyre cable with cable connector, 0.5 mm ² , 2-conductor)	1 m (flame-resistant cabtyre cable 2-conductor 0.5 mm ²)		
Insulation resistance	100 MΩ and over with 500 VDC megger			100 MΩ and over with 500 VDC megger		
Withstand voltage	No failure after 1 minute of 1,000 VAC application.			No failure after 1 minute of 1,000 VAC application.		
Shock resistance	980 m/s ²			294 m/s ²		
Ambient temperature	-10 to +60°C			-10 to +60°C		
Degree of protection	JIS C0920 (water-tight), IEC standards IP67, oil resistance			IEC Standard IP67, JIS C9020 (water-tight), oil resistance		
Weight g	1 m:61	3 m:166	5 m:272	35		1 m:76 3 m:181 5 m:289

*1 : Indicates the time from magnetic sensor detection of the piston magnet until switch output.

*2 : 3 m and 5 m lead wires are available as options.

*3 : Flame-resistant lead wires are available as options.

*4 : Switch for AC magnetic field (T2YD, T2YDT) cannot be used in DC magnetic field.

*5 : The above max. load current is 20 mA at 25°C. The current is lower than 20 mA if the operating ambient temperature around the switch is higher than 25°C.
(5 to 10 mA at 60°C)

Theoretical thrust table

(Unit: N)

Bore size (mm)	Operating direction	Working pressure MPa										
		0.1	0.15	0.2	0.3	0.4	0.5	0.6	0.7	0.8	0.9	1.0
ø40	Push	1.26 × 10 ²	1.88 × 10 ²	2.51 × 10 ²	3.77 × 10 ²	5.03 × 10 ²	6.28 × 10 ²	7.54 × 10 ²	8.80 × 10 ²	1.01 × 10 ³	1.13 × 10 ³	1.26 × 10 ³
	Pull	94.2	1.41 × 10 ²	1.88 × 10 ²	2.83 × 10 ²	3.77 × 10 ²	4.71 × 10 ²	5.65 × 10 ²	6.60 × 10 ²	7.54 × 10 ²	8.48 × 10 ²	9.42 × 10 ²
ø50	Push	1.96 × 10 ²	2.95 × 10 ²	3.93 × 10 ²	5.89 × 10 ²	7.85 × 10 ²	9.82 × 10 ²	1.18 × 10 ³	1.37 × 10 ³	1.57 × 10 ³	1.77 × 10 ³	1.96 × 10 ³
	Pull	1.65 × 10 ²	2.47 × 10 ²	3.30 × 10 ²	4.95 × 10 ²	6.60 × 10 ²	8.25 × 10 ²	9.90 × 10 ²	1.15 × 10 ³	1.32 × 10 ³	1.48 × 10 ³	1.65 × 10 ³
ø63	Push	3.12 × 10 ²	4.68 × 10 ²	6.23 × 10 ²	9.35 × 10 ²	1.25 × 10 ³	1.56 × 10 ³	1.87 × 10 ³	2.18 × 10 ³	2.49 × 10 ³	2.81 × 10 ³	3.12 × 10 ³
	Pull	2.80 × 10 ²	4.20 × 10 ²	5.61 × 10 ²	8.41 × 10 ²	1.12 × 10 ³	1.40 × 10 ³	1.68 × 10 ³	1.96 × 10 ³	2.24 × 10 ³	2.52 × 10 ³	2.80 × 10 ³
ø80	Push	5.03 × 10 ²	7.54 × 10 ²	1.01 × 10 ³	1.51 × 10 ³	2.01 × 10 ³	2.51 × 10 ³	3.02 × 10 ³	3.52 × 10 ³	4.02 × 10 ³	4.52 × 10 ³	5.03 × 10 ³
	Pull	4.54 × 10 ²	6.80 × 10 ²	9.07 × 10 ²	1.36 × 10 ³	1.81 × 10 ³	2.27 × 10 ³	2.72 × 10 ³	3.17 × 10 ³	3.63 × 10 ³	4.08 × 10 ³	4.54 × 10 ³

- LCM
- LCR
- LCG
- LCW
- LCX
- STM
- STG
- STS/STL
- STR2
- UCA2
- ULK*
- JSK/M2
- JSG
- JSC3/JSC4
- USSD
- UFCD
- USC
- UB
- JSB3
- LMB
- LML
- HCM
- HCA
- LBC
- CAC4**
- UCAC2
- CAC-N
- UCAC-N
- RCS2
- RCC2
- PCC
- SHC
- MCP
- GLC
- MFC
- BBS
- RRC
- GRC
- RV3*
- NHS
- HRL
- LN
- Hand
- Chuk
- MechHnd/Chuk
- ShkAbs
- FJ
- FK
- SpdContr
- Ending

How to order

Without switch (built-in magnet for switch)

CAC4 - A - 40 - B - 50 R - Y1

With switch (built-in magnet for switch)

CAC4 - A - 40 - B - 50 R - T0H - R B - Y1

With strong magnetic field proof (for H0, HOY switches) switch (built-in magnet for switch)

CAC4-L2 - A - 40 - B - 50 R - H0 - R B - Y1

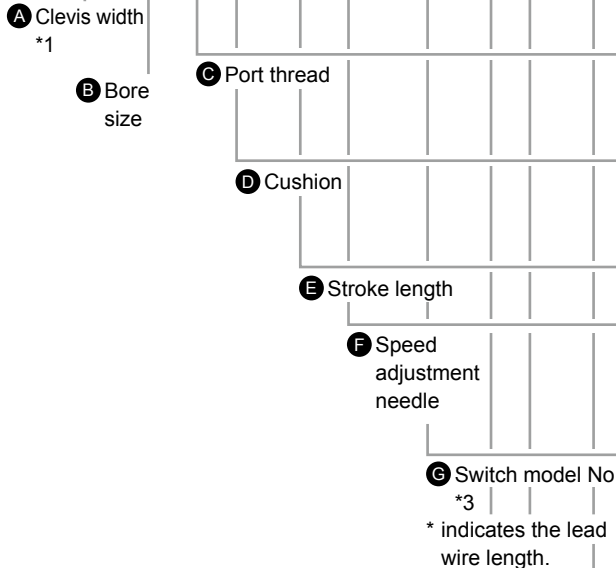

A Clevis width
*1

B Bore size

C Port thread

D Cushion

E Stroke length

F Speed adjustment needle

G Switch model No.
*3

* indicates the lead wire length.

H Switch quantity

I Switch mounting position and mounting
*5

J Accessory
*6
*7
*8

⚠ Precautions for model No. selection

- *1 : A clevis pin, split pin, and plain washer are attached with A, B, AL and BL.
- *2 : If blank is selected for **C** Port thread, the head side cushion comes with "Blank" for **D** Cushion and "H" for all other options.
- *3 : T2YD, T2YDT, T2YDU, HO and HOY are strong magnetic field proof switches.
- *4 : Cannot be selected with **G** Switch model No. "H0*", "HOY*".
- *5 : For the mounting band, a switch body + mounting bracket set + band are shipped with the product.
- *6 : A pin, split pin, and plain washer are attached with Y and Y1.
- *7 : For Q, piston rod protruding length is different from the standard. This cannot be mounted on the standard.
- *8 : When selecting "Q", only "A" can be selected for **A** Clevis width.
- *9 : Bellows max. ambient temperature 100°C, instantaneous max. temperature 200°C
- *10 : Cannot be mounted if **A** Clevis width is AL or BL.
- *11 : For the type with bellows, be sure to select a rod eye.

[Example of model No.]

CAC4-A-40B-50R-T0H-RB-Y1

Model: Clamp cylinder

- A** Clevis width : 16.5 mm
- B** Bore size : ø40 mm
- C** Port thread : Rc thread
- D** Cushion : With both sides
- E** Stroke length : 50 mm
- F** Speed adjustment needle : With rod side
- G** Switch model No. : Reed switch T0H, Lead wire length 1 m
- H** Switch quantity : 1 on rod side
- I** Switch mounting position and mounting : B
- J** Accessory : Rod clevis (SS400)

Code	Description				
A Clevis width (mm)					
	Bore size (ø)	ø40	ø50	ø63	ø80
Blank	28				●
A	16.5	●	●	●	
B	19.5	●	●	●	
AL	16.5 (Axial foot)	●	●	●	
BL	19.5 (Axial foot)	●	●	●	

B Bore size (mm)	
40	ø40
50	ø50
63	ø63
80	ø80

C Port thread	
Blank	Rc thread
N	NPT thread (made-to-order product)
G	G thread (made-to-order product)

D Cushion	
Blank / H *2	Head side cushioned
B	Both sides cushioned
N	Without cushion

E Stroke length (mm)	
50, 75, 100, 125, 150	

F Speed adjustment needle	
Blank	With both sides
R	With rod side
H	With head side
N	None

G Switch model No.					
Axial lead wire	Radial lead wire	Contact	Voltage AC DC	Display	Lead wire
T0H*	T0V*	Reed	● ●	1-color display	2-wire
T5H*	T5V*		● ●	Without indicator lamp	
T8H*	T8V*		● ●	1-color display	
T1H*	T1V*	Proximity	●	1-color display	2-wire
T2H*	T2V*		●		
T3H*	T3V*		●	1-color display	3-wire
T3PH*	T3PV*		●		
T2YH*	T2YV*		●	2-color display	2-wire
T2WH*	T2WV*		●		
T3YH*	T3YV*		●	2-color display	3-wire
T3WH*	T3WV*		●		
T2YD*	-		●	For 2-color display AC magnetic field	2-wire
T2YDT*	-		●		
T2YDU	-	●	Switch, strong magn field connector (for AC magn field, made-to-order)	2-wire	
T2JH*	T2JV*	●	1-color display off-delay		
H0*	-	Reed	●	Strong magnetic field proof switch	2-wire
HOY*	-	●	Strong magnetic field, 2-color display		

* Lead wire length	
Blank	1 m (standard)
3	3 m (option)
5	5 m (option)

H Switch quantity	
R	1 on rod side
H	1 on head side
D	2

I Switch mounting position and mounting		
Blank		
B	Tie rod mounting	
C		
Z *4	Band mounting	

* Selectable only when the switch model No. is not specified Tie rod mounting position	
Blank	Without tie rod
A	
B	
C	

J Accessory					
	Bore size	ø40	ø50	ø63	ø80
Blank	Without accessory (rod eye)	●	●	●	●
Y	Rod clevis Cast iron	●	●	●	
Y1	Rod clevis Steel	●	●	●	●
I	Rod eye Steel	●	●	●	
K	Bellows *9, *10, *11	●	●	●	
D	With dog Limit switch	●	●	●	
D1	Without dog mounting base	●	●	●	
Q	Clamp bracket	●	●	●	

How to order switch * Pay attention to the direction when mounting the tie rod. Refer to page 1014.

[Switch mounting: Tie rod type]

● T type switch

A) Switch body + mounting bracket set
(=B+C+D)

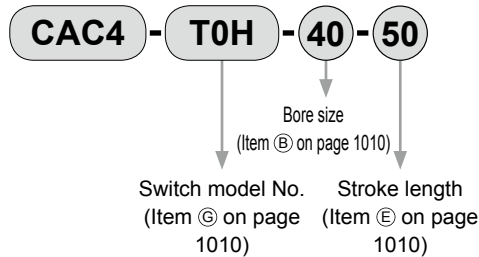

C) Mounting bracket kit

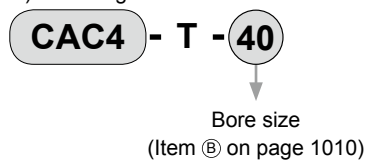

B) Switch body only

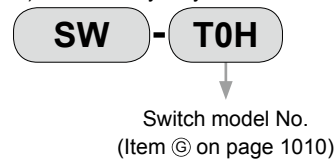

D) Mounting tie rod kit

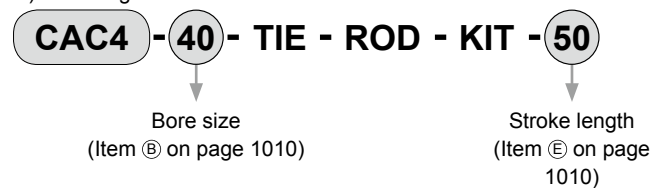

● H type switch

A) Switch body + mounting bracket set
(=B+C+D)

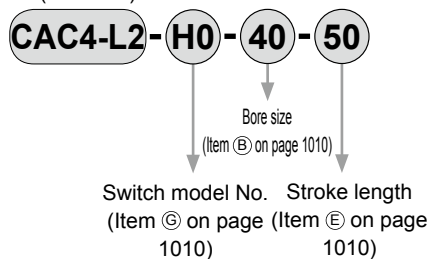

C) Mounting bracket kit

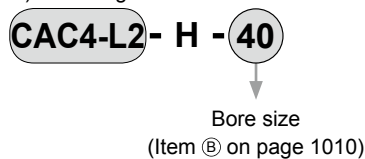

B) Switch body only

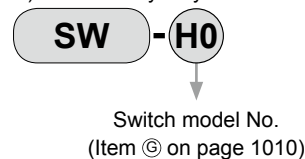

D) Mounting tie rod kit

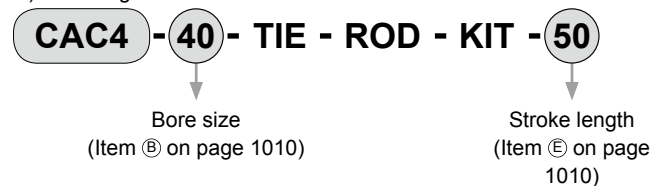

[Switch mounting: Band]

A) Switch body + mounting bracket set + band
(=B+C)

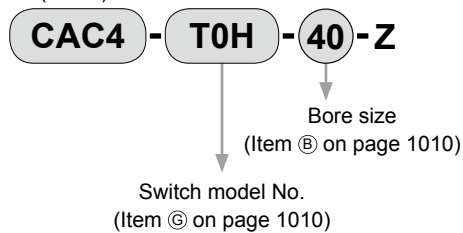

C) Mounting bracket set + band

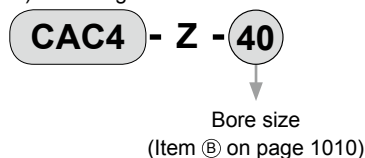

B) Switch body only

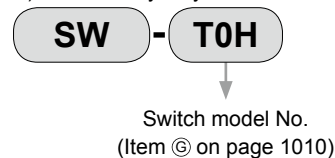

LCM
LCR
LCG
LCW
LCX
STM
STG
STS/STL
STR2
UCA2
ULK*
JSK/M2
JSG
JSC3/JSC4
USSD
UFCD
USC
UB
JSB3
LMB
LML
HCM
HCA
LBC
CAC4
UCAC2
CAC-N
UCAC-N
RCS2
RCC2
PCC
SHC
MCP
GLC
MFC
BBS
RRC
GRC
RV3*
NHS
HRL
LN
Hand
Chuk
MechHnd/Chuk
ShkAbs
FJ
FK
SpdContr
Ending

Internal structure and parts list (ø40 to ø63)

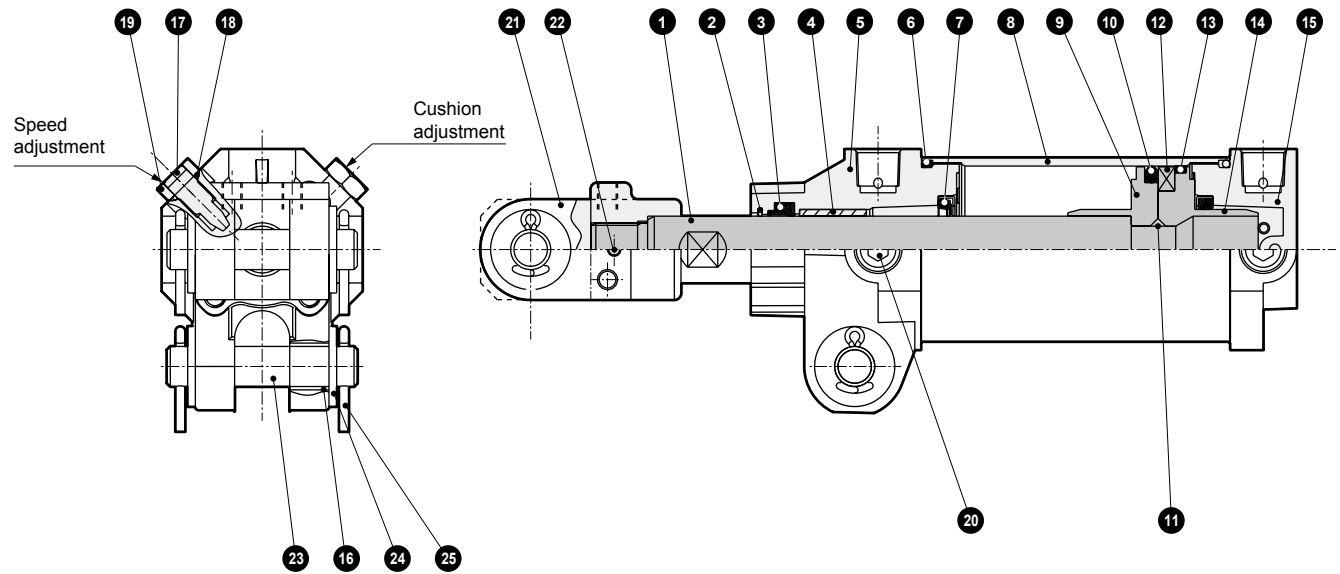

Note) Cushion packing 7 is attached to the rod side only when both sides are cushioned.

No.	Part name	Material	Remarks	No.	Part name	Material	Remarks
1	Piston rod	Steel	Industrial chrome plating	14	Piston (H)	Aluminum alloy die-casting	ø40: Aluminum alloy
2	Metal scraper	Copper alloy		15	Head cover	Aluminum alloy die-casting	Chromate
3	Rod packing	Nitrile rubber		16	Bush for clevis	Steel, copper	
4	Bush	Copper alloy		17	Needle	Copper alloy	
5	Rod cover	Aluminum alloy die-casting	Chromate	18	Needle gasket	Nitrile rubber	
6	Cylinder gasket	Nitrile rubber		19	Hexagon nut	Steel	Chromate
7	Cushion packing	Nitrile rubber, steel	Chromate	20	Hexagon socket plug	Steel	Black finish
8	Cylinder tube	Aluminum alloy	Hard alumite	21	Rod clevis	Cast iron	Manganese phosphate
9	Piston (R)	Aluminum alloy die-casting	ø40: Aluminum alloy	22	Spring pin	Steel	Black finish
10	Piston packing	Nitrile rubber		23	Clevis pin	Steel	Black finish
11	Piston gasket	Nitrile rubber		24	Plain washer	Steel	Chromate
12	Magnet	Plastic		25	Split pin	Steel	Chromate
13	Wear ring	Polyacetal resin					

Repair parts list

Bore size (mm)	Kit No.	Repair parts No.
ø40	CAC4-40K	2 3 6
ø50	CAC4-50K	7 10 13 18
ø63	CAC4-63K	

Both sides cushioned

Bore size (mm)	Kit No.	Repair parts No.
ø40	CAC4-40BK	2 3 6
ø50	CAC4-50BK	7 10 13 18
ø63	CAC4-63BK	

Internal structure and parts list (ø80)

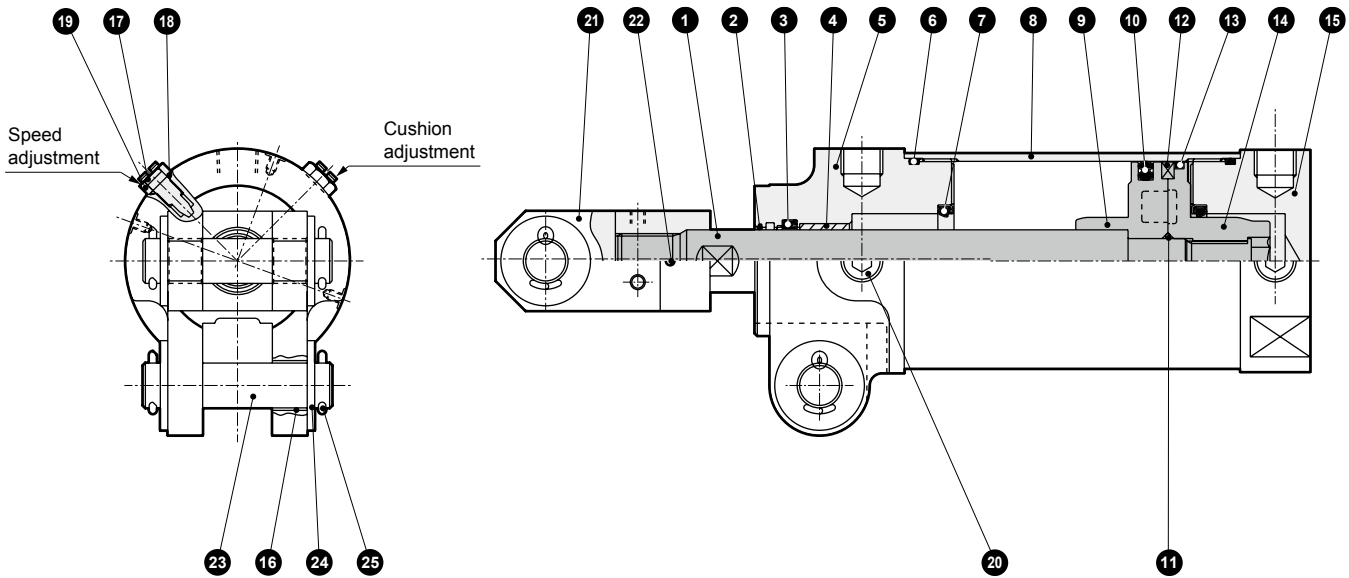

Note) Cushion packing 7 is attached to the rod side only when both sides are cushioned.

Parts list

No.	Part name	Material	Remarks	No.	Part name	Material	Remarks
1	Piston rod	Steel	Industrial chrome plating	14	Piston (H)	Aluminum alloy die-casting	
2	Metal scraper	Copper alloy		15	Head cover	Aluminum alloy	Chromate
3	Rod packing	Nitrile rubber		16	Bush for clevis	Steel, copper	
4	Bush	Copper alloy		17	Needle	Steel	Chromate
5	Rod cover	Aluminum alloy	Chromate	18	Needle gasket	Nitrile rubber	
6	Cylinder gasket	Nitrile rubber		19	Hexagon nut	Steel	Chromate
7	Cushion packing	Nitrile rubber, steel	Chromate	20	Hexagon socket plug	Steel	Black finish
8	Cylinder tube	Aluminum alloy	Hard alumite	21	Rod clevis	Steel	Black finish
9	Piston (R)	Aluminum alloy die-casting		22	Spring pin	Steel	Black finish
10	Piston packing	Nitrile rubber		23	Clevis pin	Steel	Black finish
11	Piston gasket	Nitrile rubber		24	Plain washer	Steel	Chromate
12	Magnet	Plastic		25	Split pin	Steel	Chromate
13	Wear ring	Polyacetal resin					

Repair parts list

Part name	Repair parts No.
Kit No. CAC4-80K	2 3 6 7 10 13 18

Both sides cushioned

Part name	Repair parts No.
Kit No. CAC4-80BK	2 3 6 7 10 13 18

LCM
LCR
LCG
LCW
LCX
STM
STG
STS/STL
STR2
UCA2
ULK*
JSK/M2
JSG
JSC3/JSC4
USSD
UFCD
USC
UB
JSB3
LMB
LML
HCM
HCA
LBC
CAC4
UCAC2
CAC-N
UCAC-N
RCS2
RCC2
PCC
SHC
MCP
GLC
MFC
BBS
RRC
GRC
RV3*
NHS
HRL
LN
Hand
Chuk
MechHnd/Chuk
ShkAbs
FJ
FK
SpdContr
Ending

CAC4 Series



Dimensions (ø40/ø50/ø63)

● Without rod eye

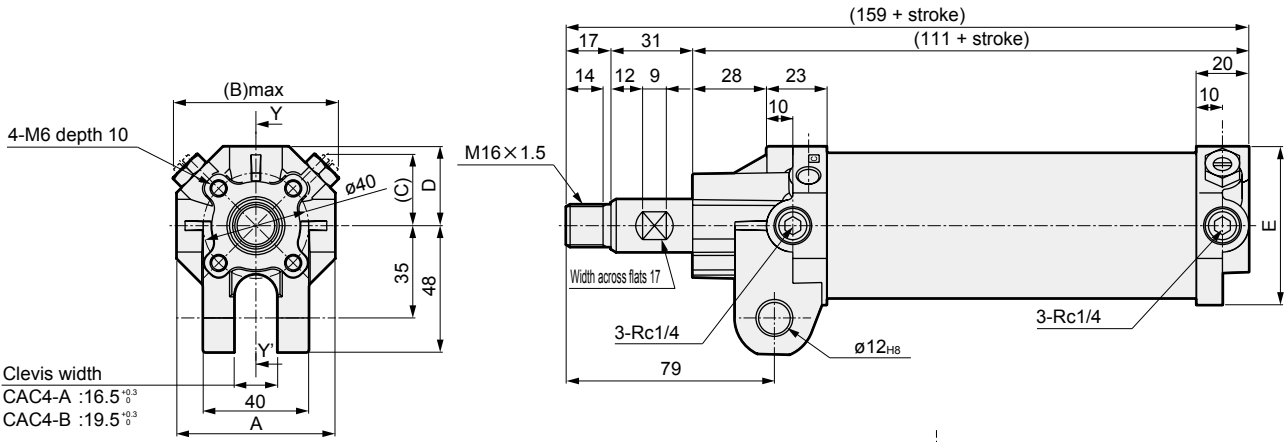

Clevis width
CAC4-A : $16.5^{+0.3}$
CAC4-B : $19.5^{+0.3}$

Code	A	(B)	(C)	D	E
Bore size					
ø40	60	63	27	30	60
ø50	60	63	27	30	60
ø63	70	66	33	35	70

Dimensions of units with T*H/V and T2YD (Switch mounting: Tie rod)

● CAC4

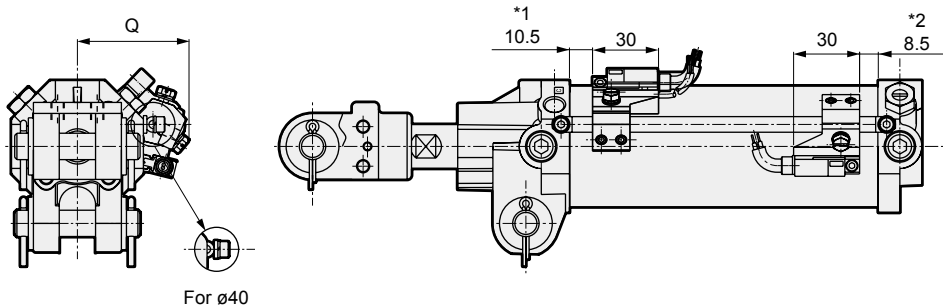

Code	Q
Bore size	
ø40	46
ø50	50
ø63	56

*1 : 5.5 for switch T8H/V and 13.5 for switch T2/3W
*2 : 3.5 for switch T8H/V and 11.5 for switch T2/3W
* Pay attention to the direction when mounting the tie rod.

H0Y mounted dimensions

● CAC4-L2

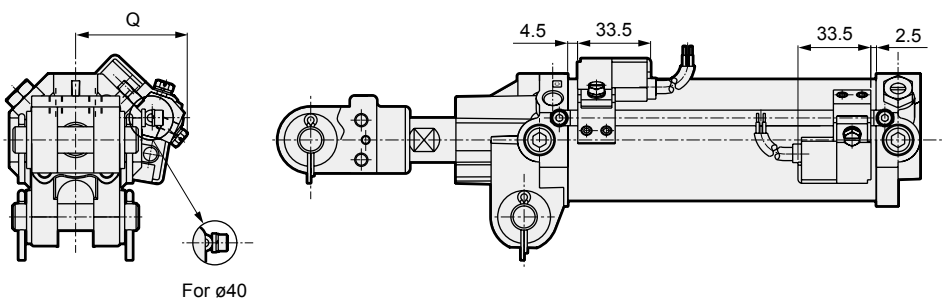

Code	Q
Bore size	
ø40	46
ø50	50
ø63	56

- LCM
- LCR
- LCG
- LCW
- L CX
- STM
- STG
- STS/STL
- STR2
- UCA2
- ULK*
- JSK/M2
- JSG
- JSC3/JSC4
- USSD
- UFCD
- USC
- UB
- JSB3
- LMB
- LML
- HCM
- HCA
- LBC
- CAC4**
- UCAC2
- CAC-N
- UCAC-N
- RCS2
- RCC2
- PCC
- SHC
- MCP
- GLC
- MFC
- BBS
- RRC
- GRC
- RV3*
- NHS
- HRL
- LN
- Hand
- Chuk
- MecHnd/Chuk
- ShkAbs
- FJ
- FK
- SpdContr
- Ending

Dimensions (ø40/ø50/ø63)



- With rod clevis (Y)

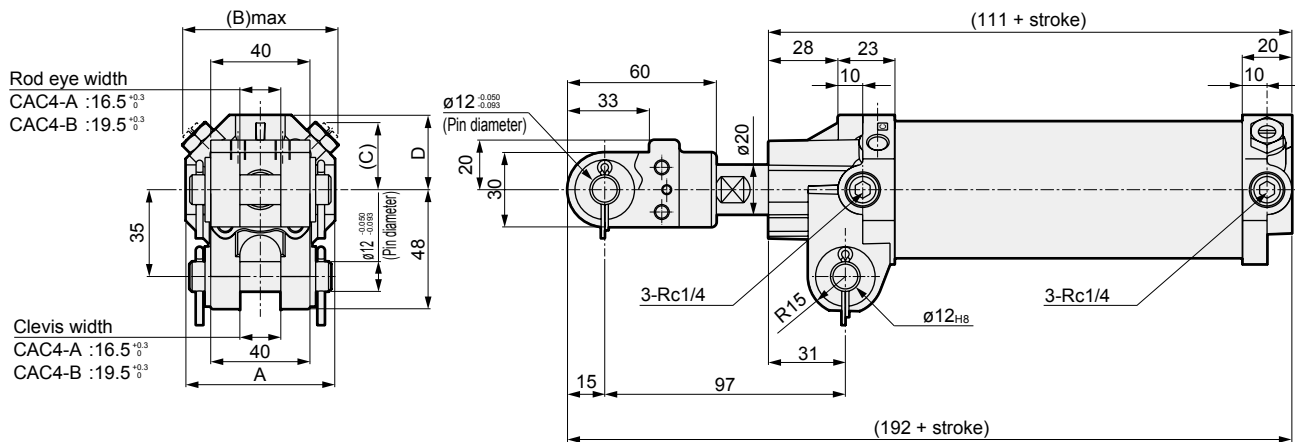

Code	A	(B)	(C)	D	E
ø40	60	63	27	30	60
ø50	60	63	27	30	60
ø63	70	66	33	35	70

- Clevis pin, rod eye pin, split pin and plain washer are attached.

- With bellows (K)

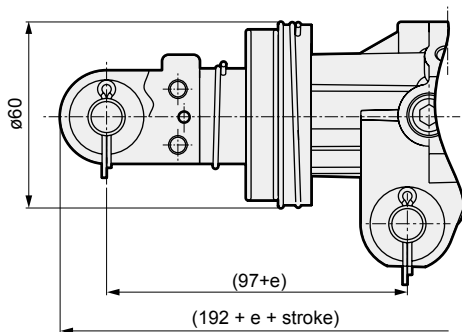

- Dimensions for units with bellows

Stroke length	With rod clevis and bellows					
	Code	50	51 to 75	76 to 100	101 to 125	126 to 150
e		0	10	18	31	31

- Axial foot
For ø40 to ø63

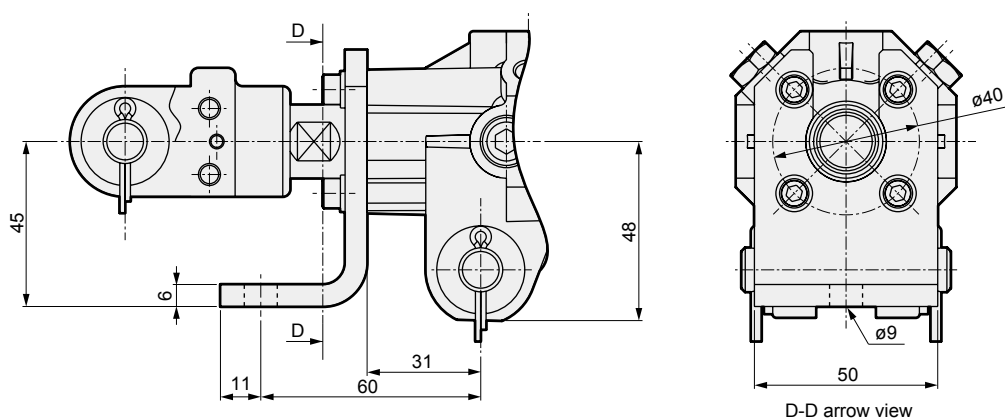

- LCM
- LCR
- LCG
- LCW
- LCX
- STM
- STG
- STS/STL
- STR2
- UCA2
- ULK*
- JSK/M2
- JSG
- JSC3/JSC4
- USSD
- UFCD
- USC
- UB
- JSB3
- LMB
- LML
- HCM
- HCA
- LBC**
- CAC4**
- UCAC2
- CAC-N
- UCAC-N
- RCS2
- RCC2
- PCC
- SHC
- MCP
- GLC
- MFC
- BBS
- RRC
- GRC
- RV3*
- NHS
- HRL
- LN
- Hand
- Chuk
- MechHnd/Chuk
- ShkAbs
- FJ
- FK
- SpdContr
- Ending



Dimensions (ø80)

● Without rod eye

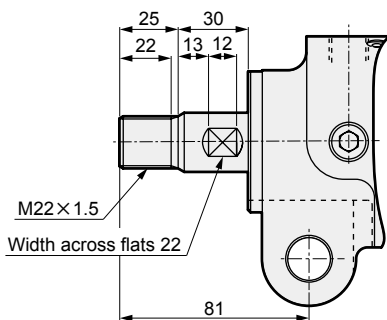

● With rod clevis (Y1), T*H/V (switch mounting: tie rod type)

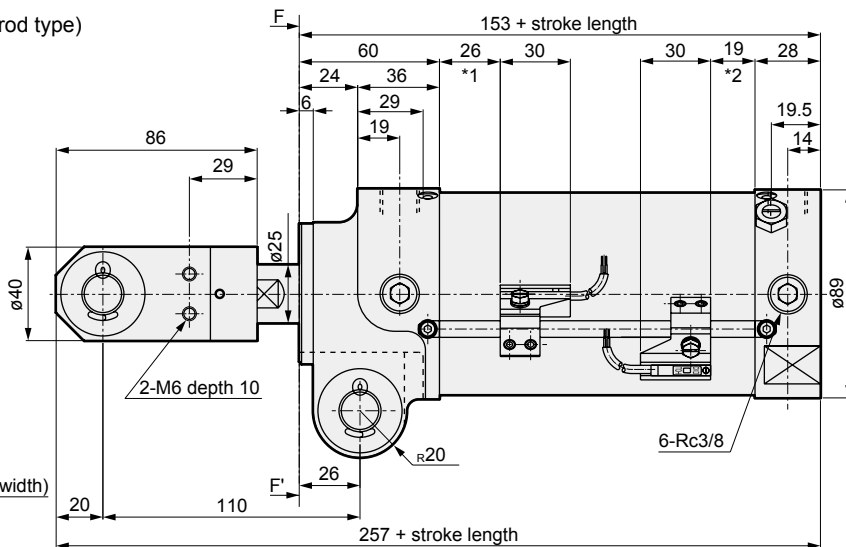
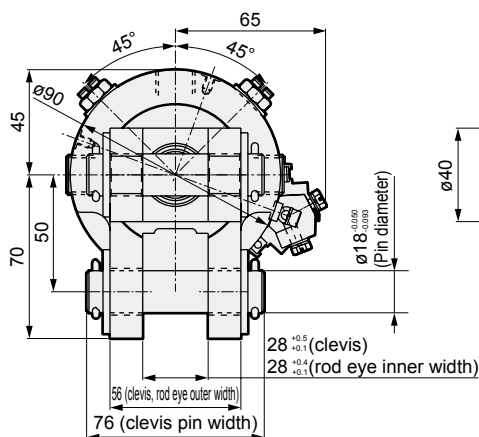

*1: 17.5 for switch T8H/V and 26 for switch T2/3W
 *2: 10.5 for switch T8H/V and 19 for switch T2/3W

F arrow view

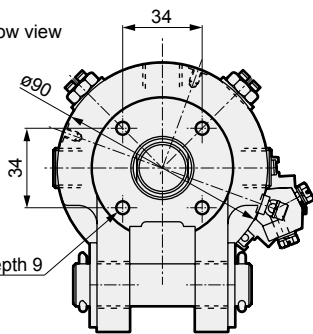

F-F' arrow view

● HOY mounted (CAC4-L2)

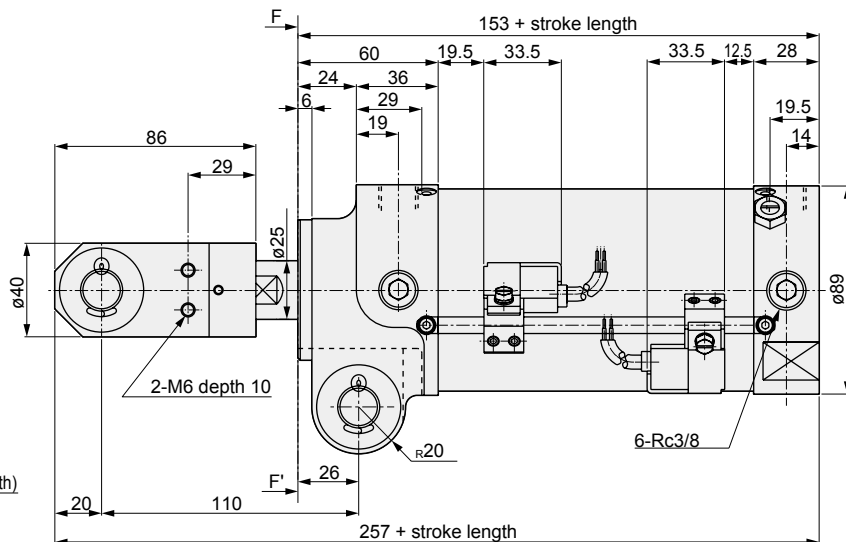
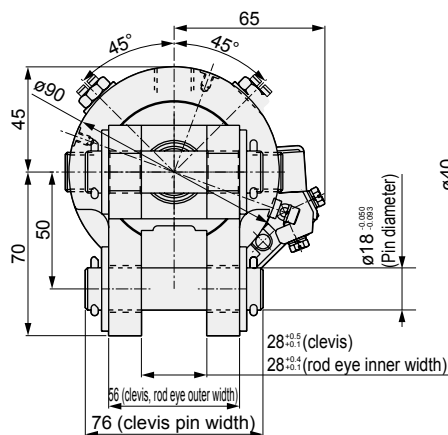

LCM
LCR
LCG
LCW
L CX
STM
STG
STS/STL
STR2
UCA2
ULK*
JSK/M2
JSG
JSC3/JSC4
USSD
UFCD
USC
UB
JSB3
LMB
LML
HCM
HCA
LBC
CAC4
UCAC2
CAC-N
UCAC-N
RCS2
RCC2
PCC
SHC
MCP
GLC
MFC
BBS
RRC
GRC
RV3*
NHS
HRL
LN
Hand
Chuk
MecHnd/Chuk
ShkAbs
FJ
FK
SpdContr
Ending

Dimensions (switch mounting: band)

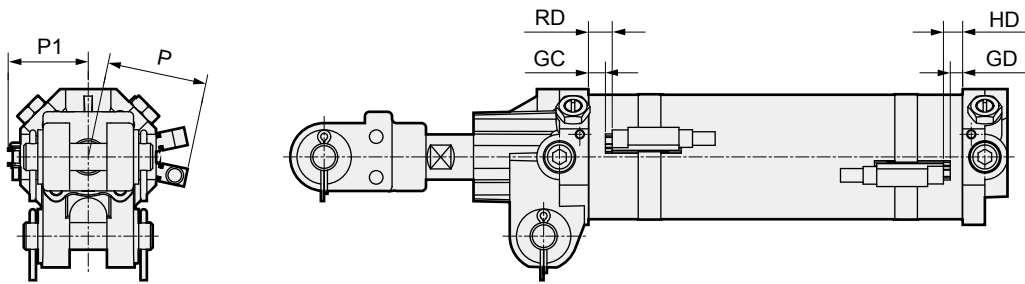

Code	T0, T5, T2, T3						T1, T2YD, T2YDT						T2Y, T3Y, T2J					
	GC	GD	RD	HD	P	P1	GC Note	GD Note	RD	HD	P	P1	GC Note	GD Note	RD	HD	P	P1
ø40	6.5	4.5	10.5	8.5	30	31	-	-	10.5	8.5	41	31	-	-	10.5	8.5	36	31
ø50	6.5	4.5	10.5	8.5	34.5	36	-	-	10.5	8.5	45.5	36	-	-	10.5	8.5	40	36
ø63	6.5	4.5	10.5	8.5	41	42.5	-	-	10.5	8.5	52	42.5	-	-	10.5	8.5	46.5	42.5
ø80	19	12	23	16	50	52	-	-	23	16	61	52	-	-	23	16	56	52

Code	T8						T2W, T3W					
	GC Note	GD Note	RD	HD	P	P1	GC	GD	RD	HD	P	P1
ø40	-	-	5.5	3.5	36	31	9.5	7.5	13.5	11.5	30	31
ø50	-	-	5.5	3.5	40	36	9.5	7.5	13.5	11.5	34.5	36
ø63	-	-	5.5	3.5	46.5	42.5	9.5	7.5	13.5	11.5	41	42.5
ø80	-	-	18	11	56	52	22	15	26	19	50	52

Note: Because the rail and the end face of the switch are on the same surface, the dimensions of GC and GD will be the same as those of RD and HD.

Dimensions: Clamp bracket (ø40 to ø63)

- Clamp bracket

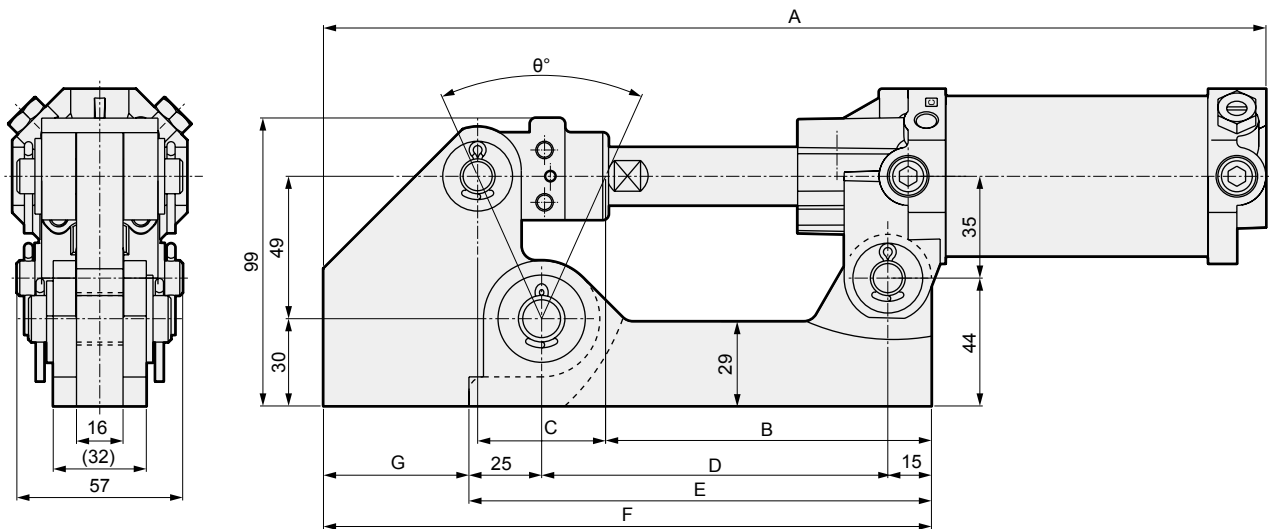

- The projection dimension of rod is different from the standard. This cannot be mounted on the standard.
- The figure is the projection dimensions. Dimension B represents the center position of the rod eye pin when the rod is retracted.
- Dimensions with bellows are the same.
- This product is mounted by welding.
- There is no ø80.
- Figure is dimensions with CAC4-A-50-Q. Configuration varies depending on the stroke.

Code	Stroke length	A	B	C	D	E	F	G	θ°
CAC4-A-50-Q	50	324	97	44	119	159	209	50	48
CAC4-A-75-Q	75	372	107	70	142	182	232	50	71
CAC4-A-100-Q	100	415	115	90	160	200	250	50	85
CAC4-A-125-Q	125	468	128	120	188	228	278	50	101
CAC4-A-150-Q	150	513	128	140	198	238	298	60	110

- LCM
- LCR
- LCG
- LCW
- LCX
- STM
- STG
- STS/STL
- STR2
- UCA2
- ULK*
- JSK/M2
- JSG
- JSC3/JSC4
- USSD
- UFCD
- USC
- UB
- JSB3
- LMB
- LML
- HCM
- HCA
- LBC
- CAC4**
- UCAC2
- CAC-N
- UCAC-N
- RCS2
- RCC2
- PCC
- SHC
- MCP
- GLC
- MFC
- BBS
- RRC
- GRC
- RV3*
- NHS
- HRL
- LN
- Hand
- Chuk
- MechHnd/Chuk
- ShkAbs
- FJ
- FK
- SpdContr
- Ending

Accessory dimensions

- Rod eye dimensions
For $\phi 40$ to $\phi 63$

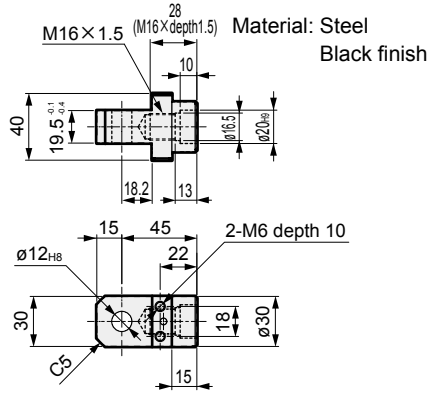

* Spring pin is attached.

Model No.	A	Applicable clamp	Weight (kg)
CAC4-IB	19.5 ^{-0.1} _{0.4}	CAC4-A, CAC4-B	0.27

- Rod clevis steel (Y1) dimensions
For $\phi 40$ to $\phi 63$

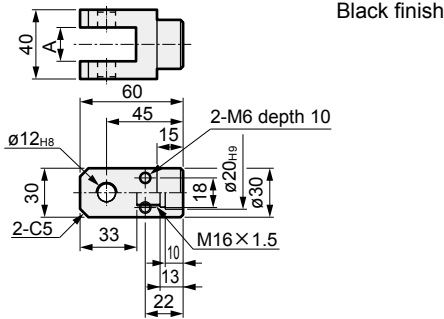

* Pin, split pin, spring pin and plain washer are attached.

Model No.	A	Applicable clamp	Weight (kg)
CAC4-Y1A	16.5 ^{+0.3} ₀	CAC4-A	0.37
CAC4-Y1B	19.5 ^{+0.3} ₀	CAC4-B	0.37

- Clevis pin dimensions
For $\phi 40$ to $\phi 63$

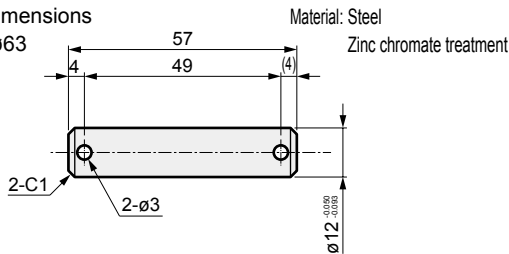

* A split pin and flat washer are attached.

Model No.	Applicable clamp	Weight (kg)
CAC4-P	CAC4-A, CAC4-B	0.05

- Limit switch mounting base dimensions

Material: Steel, black finish

- Dog bracket dimensions
For $\phi 40$ to $\phi 63$

Material: Steel, black finish

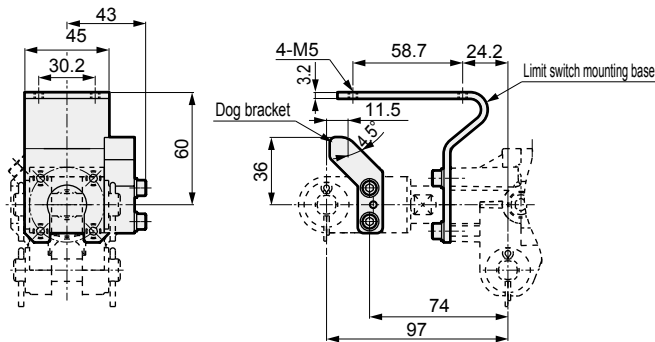

● Use WLH2 limit switch [OMRON] or equivalent.

Model No.	Part name	Applicable clamp	Weight (kg)
CAC4-L	Limit switch mounting base	CAC4-A, CAC4-B	0.18
CAC4-D	Dog bracket	CAC4-A, CAC4-B	0.08

- Rod clevis steel (Y) dimensions
For $\phi 40$ to $\phi 63$

Material: Cast iron
Black finish

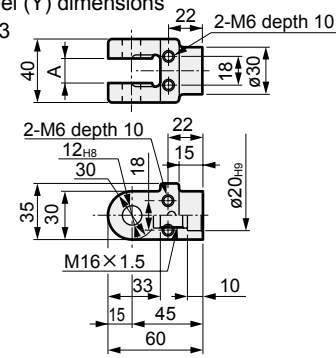

* Pin, split pin, spring pin and plain washer are attached.

Model No.	A	Applicable clamp	Weight (kg)
CAC4-YA	16.5 ^{+0.3} ₀	CAC4-A	0.37
CAC4-YB	19.5 ^{+0.3} ₀	CAC4-B	0.37

For $\phi 80$

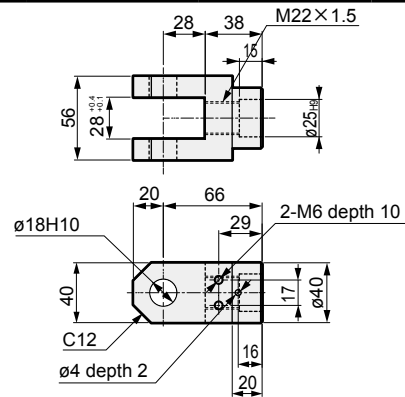

* Pin, split pin, spring pin and plain washer are attached.

Model No.	Applicable clamp	Weight (kg)
CAC4-Y1-80	CAC4-A, CAC4-B	0.95

For $\phi 80$

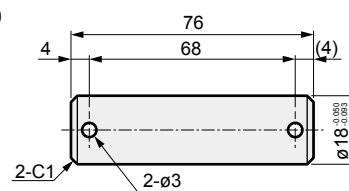

* A split pin and flat washer are attached.

Model No.	Applicable clamp	Weight (kg)
CAC4-P-80	CAC4-A, CAC4-B	0.15

- AL, BL axial foot bracket

Material: Steel, black finish

For $\phi 40$ to $\phi 63$

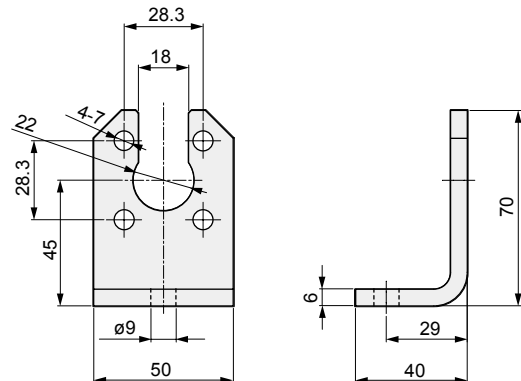

* 4 hexagon socket head cap screws and disc spring washers are attached.

Model No.	Applicable clamp	Weight (kg)
CAC4-F	CAC4-A, CAC4-B	0.21

MEMO

LCM
LCR
LCG
LCW
LCX
STM
STG
STS/STL
STR2
UCA2
ULK*
JSK/M2
JSG
JSC3/JSC4
USSD
UFCD
USC
UB
JSB3
LMB
LML
HCM
HCA
LBC
CAC4
UCAC2
CAC-N
UCAC-N
RCS2
RCC2
PCC
SHC
MCP
GLC
MFC
BBS
RRC
GRC
RV3*
NHS
HRL
LN
Hand
Chuk
MechHnd/Chuk
ShkAbs
FJ
FK
SpdContr
Ending

LCM
LCR
LCG
LCW
LCX
STM
STG
STS/STL
STR2
UCA2
ULK*
JSK/M2
JSG
JSC3/JSC4
USSD
UFCD
USC
UB
JSB3
LMB
LML
HCM
HCA
LBC
CAC4
UCAC2
CAC-N
UCAC-N
RCS2
RCC2
PCC
SHC
MCP
GLC
MFC
BBS
RRC
GRC
RV3*
NHS
HRL
LN
Hand
Chuk
MechHnd/Chuk
ShkAbs
FJ
FK
SpdContr
Ending

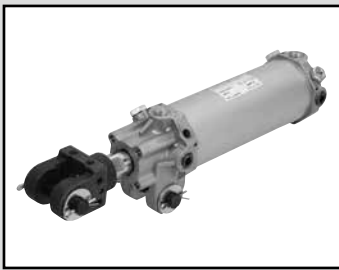

Clamp cylinder/anti-spatter adherence CAC4-G4 Series

● Bore size: ø40/ø50/ø63/ø80

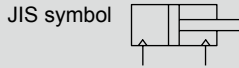

Specifications

Item	CAC4-G4/CAC4-G4L2			
Bore size mm	ø40	ø50	ø63	ø80
Actuation	Double acting			
Working fluid	Compressed air			
Max. working pressure MPa	1.0 (≈150 psi, 10 bar)			
Min. working pressure MPa	0.1 (≈15 psi, 1 bar)			
Proof pressure MPa	1.6 (≈230 psi, 16 bar)			
Ambient temperature °C	-10 (14°F) to 60 (140°F) (no freezing)			
Port size	Rc1/4			Rc3/8
Standard stroke length mm	50, 75, 100, 125, 150			
Working piston speed mm/s	50 to 500	50 to 400	50 to 300	
Cushion	Head side air cushioned			
Effective air cushion length mm	13.5			15.4
Lubrication	Not required (use turbine oil ISO VG32 if necessary for lubrication)			
Mounting	Clevis bracket			

* Operate within the absorbed energy. Refer to table below.

Stroke length

Bore size (mm)	Standard stroke length (mm)	Max. stroke length (mm)	Min. stroke length (mm)	Min. stroke with switch (mm)
ø40	50, 75	150	50	50
ø50	100, 125			
ø63	150			
ø80				

Note: Products other than standard stroke length are made-to-order products.

Cushion characteristics table

Bore size (mm)	Effective cushion length (mm)	Allowable energy (J)	
		With cushion	Without cushion
ø40	13.5	5.14	0.137
ø50	13.5	6.41	0.137
ø63	13.5	11.37	0.205
ø80	15.4	25.4	0.360

● Cushion

The purpose of the cushion is to absorb the piston's kinetic energy with air compressibility, preventing the piston and cover from colliding at the stroke end. Therefore, the cushion itself does not reduce the piston speed at the stroke end.

Note that the left table shows the kinetic energy which can be absorbed by the cushion. If the kinetic energy exceeds these values, or if bouncing caused by the air compressibility is to be avoided, consider using another shock absorber.

$$\text{Kinetic energy (J)} = \frac{1}{2} \times \text{load weight (kg)} \times [\text{speed (m/s)}]^2$$

Cylinder weight

(Unit: kg)

Bore size (mm)	Product weight / 0 mm stroke	Additional weight per 100 mm stroke length	Accessory weight					Switch weight	Mounting bracket weight			Tie rod weight at 0 mm stroke	Additional weight of tie rod per S = 10 mm
			Axial foot	Rod clevis	Rod eye	Limit switch mounting base	Dog bracket		T type		H type		
									Tie rod mount	Band mounting			
ø40	0.75	0.34	0.21	0.37	0.27	0.18	0.08	Refer to the weight in the switch specifications.	0.021	0.007	0.024	0.019	0.003
ø50	0.82	0.36								0.008			
ø63	1.03	0.39								0.009			
ø80	2.80	0.60								-			

(Example) Product weight of CAC4-G4-A-40-150-Y

- Product weight for stroke length 0 mm ... 0.75 kg
- Additional weight for stroke length 150 mm ... $0.34 \times \frac{150}{100} = 0.51$ kg
- Accessory weight (rod clevis) 0.37 kg
- Product weight $0.75 + 0.51 + 0.37 = 1.63$ kg

Switch specifications

- Proximity switch for AC magnetic field

Item	Proximity 2-wire	
	T2YD, T2YDT (*4)	T2YDU (Made to order)
Applications	Dedicated for programmable controller	
Indicator lamp	Red/green LED (Lit when ON)	
Load voltage	24 VDC ±10%	
Load current	5 to 20 mA	
Internal voltage drop	6V or less	
Leakage current	1.0 mA or less	
Output delay time *1 (ON Delay, OFF delay)	60 ms or less	
Lead wire length	1 m (oil resistant vinyl cabtyre cable ø 6, 0.5 mm ² x 2-conductor) *2, *3	0.3 m (flame-resistant cabtyre cable with cable connector, 0.5 mm ² , 2-conductor)
Insulation resistance	100 MΩ and over with 500 VDC megger	
Withstand voltage	No failure after 1 minute of 1,000 VAC.	
Shock resistance	980 m/s ²	
Ambient temperature	-10 to +60°C	
Degree of protection	JIS C0920 (water-tight), IEC standards IP67, oil resistance	
Weight g	1 m:61 3 m:166 5 m:272	35

- *1: Indicates the time from magnetic sensor detection of the piston magnet until switch output.
- *2: 3 m and 5 m lead wires are available as options.
- *3: Flame-resistant lead wires are available as options.
- *4: Switch for AC magnetic field (T2YD, T2YDT) cannot be used in DC magnetic field.
- *5: Refer to Ending Page 1 for detailed switch specifications and dimensions.

- Strong magnetic field proof reed switch

Item	Reed 2-wire		
	HO	HOY (2-color display)	
Applications	For programmable controller, relay	Dedicated for programmable controller	
Load voltage	12/24 VDC	110 VAC	24 VDC
Load current	5 to 50 mA	7 to 20 mA	5 to 20 mA (*1)
Internal voltage drop	5V or less		6V or less
Leakage current	10 μA or less		10 μA or less
Indicator lamp	Green LED (Lit when ON)		Red/green LED (Lit when ON)
Lead wire (standard)	1 m (flame-resistant cabtyre cable ø6, 0.5 mm ² x 2-conductor)		
Insulation resistance	100 MΩ and over with 500 VDC megger		
Withstand voltage	No failure after 1 minute of 1,000 VAC application.		
Shock resistance	294 m/s ²		
Ambient temperature	-10 to +60°C		
Degree of protection	IEC Standard IP67, JIS C9020 (water-tight), oil resistance		
Weight g	1 m:76 3 m:181 5 m:289		

- *1: The above max. load current is 20 mA at 25°C. The current is lower than 20 mA if the operating ambient temperature around the switch is higher than 25°C. (5 to 10 mA at 60°C)

Theoretical thrust table

(Unit: N)

Bore size (mm)	Operating direction	Working pressure MPa										
		0.1	0.15	0.2	0.3	0.4	0.5	0.6	0.7	0.8	0.9	1.0
ø40	Push	1.26 × 10 ²	1.88 × 10 ²	2.51 × 10 ²	3.77 × 10 ²	5.03 × 10 ²	6.28 × 10 ²	7.54 × 10 ²	8.80 × 10 ²	1.01 × 10 ³	1.13 × 10 ³	1.26 × 10 ³
	Pull	94.2	1.41 × 10 ²	1.88 × 10 ²	2.83 × 10 ²	3.77 × 10 ²	4.71 × 10 ²	5.65 × 10 ²	6.60 × 10 ²	7.54 × 10 ²	8.48 × 10 ²	9.42 × 10 ²
ø50	Push	1.96 × 10 ²	2.95 × 10 ²	3.93 × 10 ²	5.89 × 10 ²	7.85 × 10 ²	9.82 × 10 ²	1.18 × 10 ³	1.37 × 10 ³	1.57 × 10 ³	1.77 × 10 ³	1.96 × 10 ³
	Pull	1.65 × 10 ²	2.47 × 10 ²	3.30 × 10 ²	4.95 × 10 ²	6.60 × 10 ²	8.25 × 10 ²	9.90 × 10 ²	1.15 × 10 ³	1.32 × 10 ³	1.48 × 10 ³	1.65 × 10 ³
ø63	Push	3.12 × 10 ²	4.68 × 10 ²	6.23 × 10 ²	9.35 × 10 ²	1.25 × 10 ³	1.56 × 10 ³	1.87 × 10 ³	2.18 × 10 ³	2.49 × 10 ³	2.81 × 10 ³	3.12 × 10 ³
	Pull	2.80 × 10 ²	4.20 × 10 ²	5.61 × 10 ²	8.41 × 10 ²	1.12 × 10 ³	1.40 × 10 ³	1.68 × 10 ³	1.96 × 10 ³	2.24 × 10 ³	2.52 × 10 ³	2.80 × 10 ³
ø80	Push	5.03 × 10 ²	7.54 × 10 ²	1.01 × 10 ³	1.51 × 10 ³	2.01 × 10 ³	2.51 × 10 ³	3.02 × 10 ³	3.52 × 10 ³	4.02 × 10 ³	4.52 × 10 ³	5.03 × 10 ³
	Pull	4.54 × 10 ²	6.80 × 10 ²	9.07 × 10 ²	1.36 × 10 ³	1.81 × 10 ³	2.27 × 10 ³	2.72 × 10 ³	3.17 × 10 ³	3.63 × 10 ³	4.08 × 10 ³	4.54 × 10 ³

- LCM
- LCR
- LCG
- LCW
- LCX
- STM
- STG
- STS/STL
- STR2
- UCA2
- ULK*
- JSK/M2
- JSG
- JSC3/JSC4
- USSD
- UFCD
- USC
- UB
- JSB3
- LMB
- LML
- HCM
- HCA
- LBC
- CAC4**
- UCAC2
- CAC-N
- UCAC-N
- RCS2
- RCC2
- PCC
- SHC
- MCP
- GLC
- MFC
- BBS
- RRC
- GRC
- RV3*
- NHS
- HRL
- LN
- Hand
- Chuk
- MechHnd/Chuk
- ShkAbs
- FJ
- FK
- SpdContr
- Ending

CAC4-G4 Series

How to order

Without switch (built-in magnet for switch)

CAC4-G4 - A - 40 B - 50 R - Y1

With switch (built-in magnet for switch)

CAC4-G4 - A - 40 B - 50 R - T2YD - R B - Y1

With strong magnetic field proof (for H0, HOY switches) switch (built-in magnet for switch)

CAC4-G4L2 - A - 40 B - 50 R - H0 - R B - Y1

A Clevis width
*1

B Bore size **C** Port thread

D Cushion

E Stroke length

F Speed adjustment
Needle

G Switch model No.
*3
* indicates the lead wire length.

H Switch quantity

I Switch mounting position
and mounting
*5

J Accessory
*6
*7
*8

⚠ Precautions for model No. selection

*1: A clevis pin, split pin, and plain washer are attached with A, B, AL and BL.

The clevis width and rod clevis width are the same.

*2: If blank is selected for **C** Port thread, the head side cushion comes with "Blank" for **D** Cushion and "H" for all other options.

*3: T2YD, T2YDT, T2YDU, HO and HOY are strong magnetic field proof switches.

*4: Cannot be selected with **G** Switch model No. "HO*", "HOY**".

*5: For the mounting band, a switch body + mounting bracket set + band are shipped with the product.

*6: A pin, split pin, and plain washer are attached with Y and Y1.

*7: For Q, piston rod protruding length is different from the standard. This cannot be mounted on the standard.

*8: When selecting "Q", only "A" can be selected for **A** Clevis width.

[Example of model No.]

CAC4-G4-A-40B-50R-T2YD-RB-Y1

Models: Clamp cylinder/anti-spatter adherence

- A** Clevis width : 16.5 mm
- B** Bore size : $\varnothing 40$ mm
- C** Port thread : Rc thread
- D** Cushion : With both sides
- E** Stroke length : 50 mm
- F** Speed adjustment needle : With rod side
- G** Switch model No. : Proximity switch T2YD, Lead wire length 1 m
- H** Switch quantity : 1 on rod side
- I** Switch mounting position and mounting : B
- J** Accessory : Rod clevis (SS400)

Code	Description				
A Clevis width (mm)					
	Bore size (\varnothing)	$\varnothing 40$	$\varnothing 50$	$\varnothing 63$	$\varnothing 80$
Blank	28				●
A	16.5	●	●	●	
B	19.5	●	●	●	
AL	16.5 (Axial foot)	●	●	●	
BL	19.5 (Axial foot)	●	●	●	

B Bore size (mm)	
40	$\varnothing 40$
50	$\varnothing 50$
63	$\varnothing 63$
80	$\varnothing 80$

C Port thread	
Blank	Rc thread
N	NPT thread
G	G thread

D Cushion	
Blank / H *2	Head side cushioned
B	Both sides cushioned
N	Without cushion

E Stroke length (mm)	
50, 75, 100, 125, 150	

F Speed adjustment needle	
Blank	With both sides
R	With rod side
H	With head side
N	None

G Switch model No.					
Lead wire	Lead wire	Contact	Voltage	Display	Lead wire
Straight	L-shaped		AC DC		
T2YD*	-	Proximity	●	2-color display for AC magnetic field	2-wire
T2YDT*	-		●		
T2YDU	-	Reed	●	Switch with connector (AC magnetic field)	
H0*	-		●		
HOY*	-		●	Strong magnetic field 2-color display	

* Lead wire length	
Blank	1 m (standard)
3	3 m (option)
5	5 m (option)

H Switch quantity	
R	1 on rod side
H	1 on head side
D	2

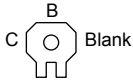
I Switch mounting position and mounting		
Blank		
B	Tie rod mounting	
C		
Z *4	Band mounting	

* Selectable only when the switch model No. is not specified	
Tie rod mounting position	
Blank	Without tie rod
A	
B	
C	

J Accessory					
	Bore size	$\varnothing 40$	$\varnothing 50$	$\varnothing 63$	$\varnothing 80$
Blank	Without accessory (rod eye)	●	●	●	●
Y	Rod clevis Cast iron	●	●	●	
Y1	Rod clevis Steel	●	●	●	●
I	Rod eye Steel	●	●	●	
D	With dog Limit switch	●	●	●	
D1	Without dog mounting base	●	●	●	
Q	Clamp bracket	●	●	●	

How to order switch

● T2YD* type switch

A) Switch body + mounting bracket set
(=B+C+D)

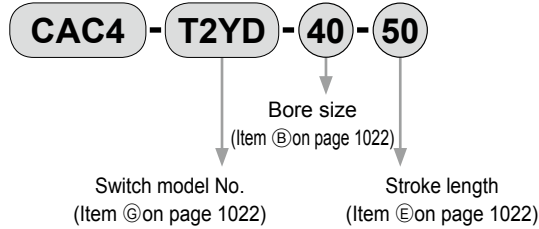

B) Switch body only

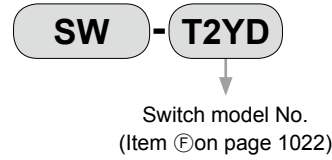

C) Mounting bracket kit

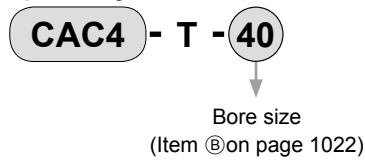

D) Mounting tie rod kit

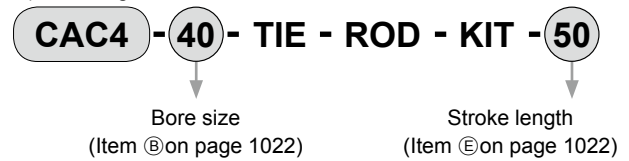

● H type switch

A) Switch body + mounting bracket set
(=B+C+D)

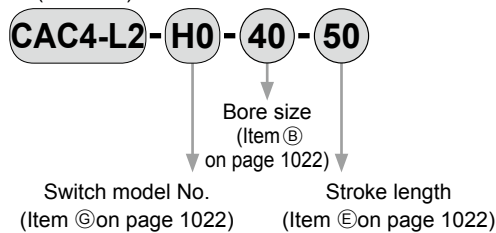

B) Switch body only

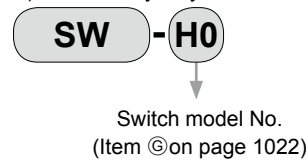

C) Mounting bracket kit

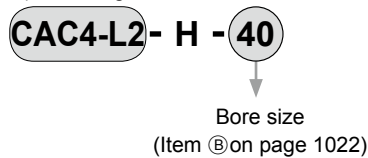

D) Mounting tie rod kit

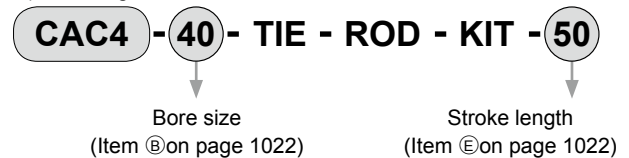

[Switch mounting: Band]

A) Switch body + mounting bracket set + band
(=B+C)

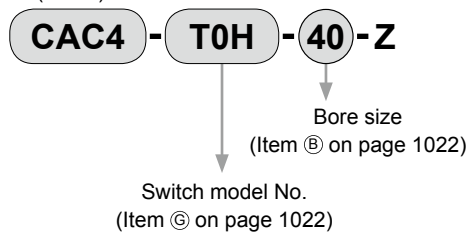

B) Switch body only

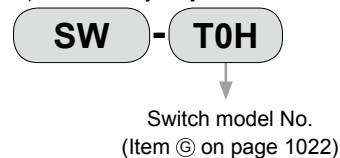

C) Mounting bracket set + band

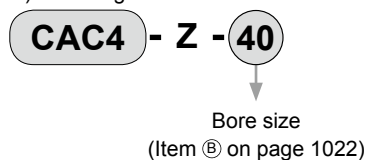

LCM
LCR
LCG
LCW
LCX
STM
STG
STS/STL
STR2
UCA2
ULK*
JSK/M2
JSG
JSC3/JSC4
USSD
UFCD
USC
UB
JSB3
LMB
LML
HCM
HCA
LBC
CAC4
UCAC2
CAC-N
UCAC-N
RCS2
RCC2
PCC
SHC
MCP
GLC
MFC
BBS
RRC
GRC
RV3*
NHS
HRL
LN
Hand
Chuk
MechHnd/Chuk
ShkAbs
FJ
FK
SpdContr
Ending

CAC4-G4 Series

Internal structure and parts list (ø40 to ø63)

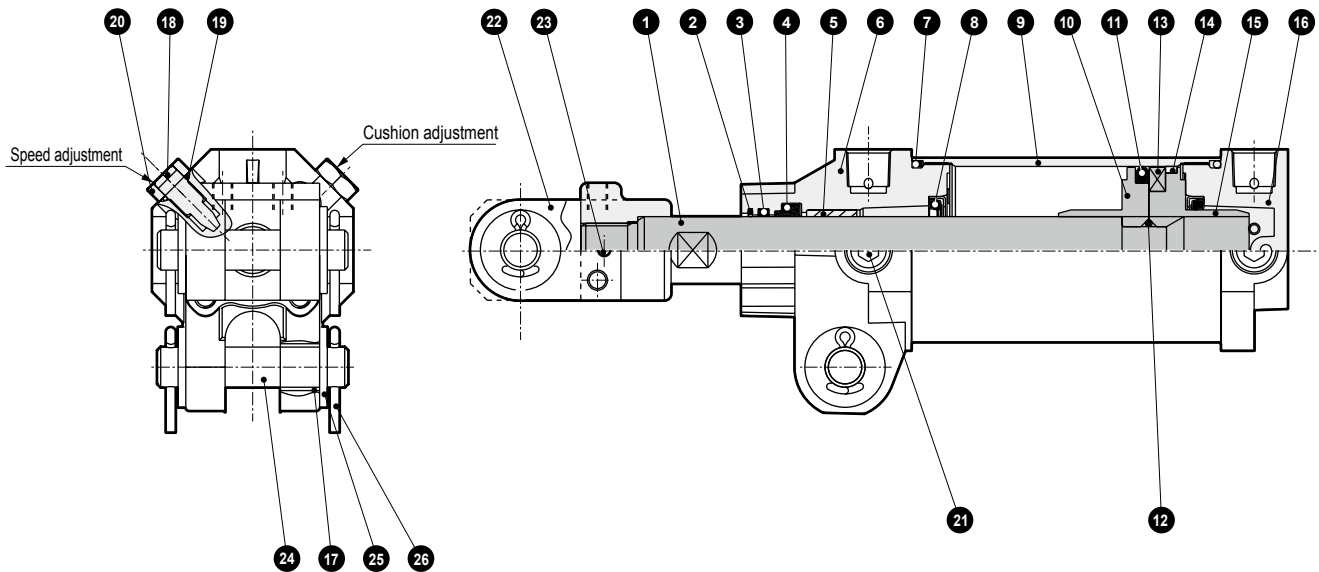

Note) Cushion packing ⑧ is attached to the rod side only when both sides are cushioned.

No.	Part name	Material	Remarks	No.	Part name	Material	Remarks
1	Piston rod	Steel	Industrial chrome plating	14	Wear ring	Polyacetal resin	
2	Metal scraper	Copper alloy		15	Piston (H)	Aluminum alloy die-casting	ø40: Aluminum alloy
3	Lube keeping structure	Special rubber		16	Head cover	Aluminum alloy die-casting	Chromate
4	Rod packing	Nitrile rubber		17	Bush for clevis	Steel, copper	
5	Bush	Copper alloy		18	Needle	Copper alloy	
6	Rod cover	Aluminum alloy die-casting	Chromate	19	Needle gasket	Nitrile rubber	
7	Cylinder gasket	Nitrile rubber		20	Hexagon nut	Steel	Chromate
8	Cushion packing	Nitrile rubber, steel	Chromate	21	Hexagon socket plug	Steel	Black finish
9	Cylinder tube	Aluminum alloy	Hard alumite treatment	22	Rod clevis	Cast iron	Manganese phosphate
10	Piston (R)	Aluminum alloy die-casting	ø40: Aluminum alloy	23	Spring pin	Steel	Black finish
11	Piston packing	Nitrile rubber		24	Clevis pin	Steel	Black finish
12	Piston gasket	Nitrile rubber		25	Plain washer	Steel	Chromate
13	Magnet	Plastic		26	Split pin	Steel	Chromate

Internal structure and parts list (ø80)

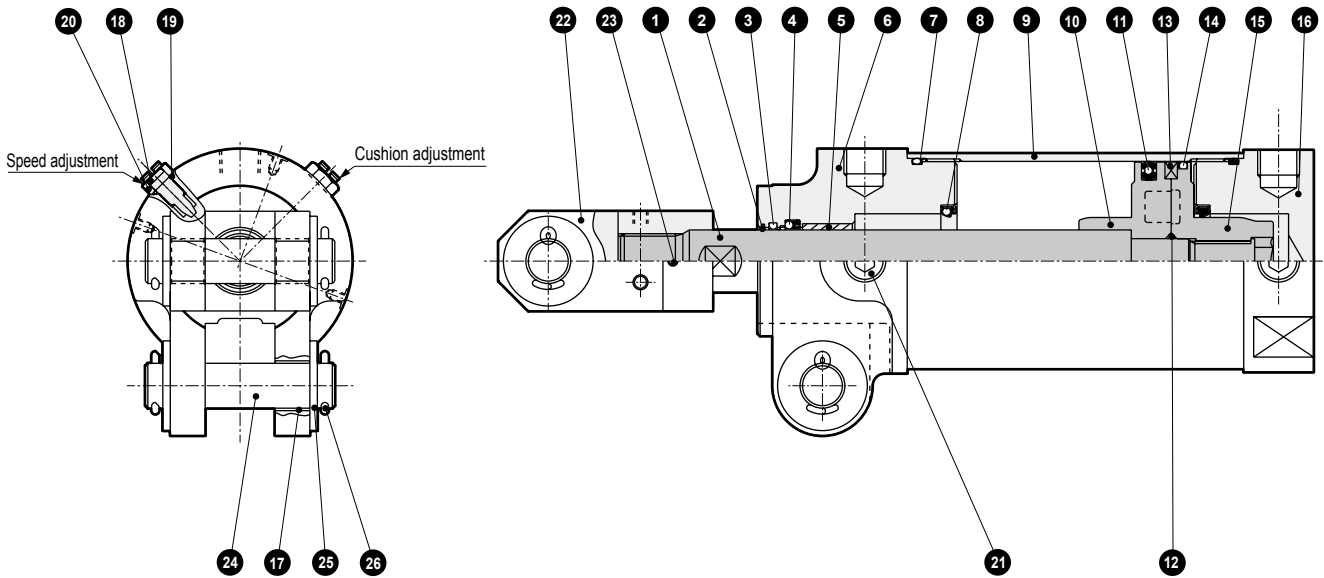

Note) Cushion packing ⑧ is attached to the rod side only when both sides are cushioned.

No.	Part name	Material	Remarks	No.	Part name	Material	Remarks
1	Piston rod	Steel	Industrial chrome plating	14	Wear ring	Polyacetal resin	
2	Metal scraper	Copper alloy		15	Piston (H)	Aluminum alloy die-casting	
3	Lube keeping structure	Special rubber		16	Head cover	Aluminum alloy	Chromate
4	Rod packing	Nitrile rubber		17	Bush for clevis	Steel, copper	
5	Bush	Copper alloy		18	Needle	Steel	Chromate
6	Rod cover	Aluminum alloy casting	Chromate	19	Needle gasket	Nitrile rubber	
7	Cylinder gasket	Nitrile rubber		20	Hexagon nut	Steel	Chromate
8	Cushion packing	Nitrile rubber, steel	Chromate	21	Hexagon socket plug	Steel	Black finish
9	Cylinder tube	Aluminum alloy	Hard alumite treatment	22	Rod clevis	Steel	Black finish
10	Piston (R)	Aluminum alloy die-casting		23	Spring pin	Steel	Black finish
11	Piston packing	Nitrile rubber		24	Clevis pin	Steel	Black finish
12	Piston gasket	Nitrile rubber		25	Plain washer	Steel	Chromate
13	Magnet	Plastic		26	Split pin	Steel	Chromate

Dimensions

Same as double acting/single rod. Refer to pages 1014 to 1017.

For accessories, refer to page 1018.

- LCM
- LCR
- LCG
- LCW
- LCX
- STM
- STG
- STS/STL
- STR2
- UCA2
- ULK*
- JSK/M2
- JSG
- JSC3/JSC4
- USSD
- UFCD
- USC
- UB
- JSB3
- LMB
- LML
- HCM
- HCA
- LBC
- CAC4**
- UCAC2
- CAC-N
- UCAC-N
- RCS2
- RCC2
- PCC
- SHC
- MCP
- GLC
- MFC
- BBS
- RRC
- GRC
- RV3*
- NHS
- HRL
- LN
- Hand
- Chuk
- MechHnd/Chuk
- ShkAbs
- FJ
- FK
- SpdContr
- Ending

T2YDU Series

LCM
LCR
LCG
LCW
LCX
STM
STG
STS/STL
STR2
UCA2
ULK*
JSK/M2
JSG
JSC3/JSC4
USSD
UFCD
USC
UB
JSB3
LMB
LML
HCM
HCA
LBC
CAC4
UCAC2
CAC-N
UCAC-N
RCS2
RCC2
PCC
SHC
MCP
GLC
MFC
BBS
RRC
GRC
RV3*
NHS
HRL
LN
Hand
Chuk
MecHnd/Chuk
ShkAbs
FJ
FK
SpdContr
Ending

Specifications

Model No.	T2YDU (Made to order)
Item	
Applications	Dedicated for DC programmable controller
Switch polarity	No polarity
Indicator lamp	Red/green LED (Lit when ON) (Refer to Fig.1)
Load voltage	24 VDC \pm 10%
Load current	DC5 to 20 mA
Internal voltage drop	6V or less
Leakage current	1.0 mA or less
Lead wire	Flame-resistant cabtyre cable with cable connector, 0.5 mm ² , 2-conductor
Insulation resistance	100 M Ω and over with 500 VDC megger
Withstand voltage	No failure after 1 minute of 1,000 VAC.
Shock resistance	980 m/s ²
Output delay time (ON Delay, OFF delay)	60 ms or less
Operating ambient temperature	-10 to +60°C
Storage ambient temperature	-20 to +80°C
Degree of protection	JIS C0920 (water-tight), IP67, oil resistance

Operation chart

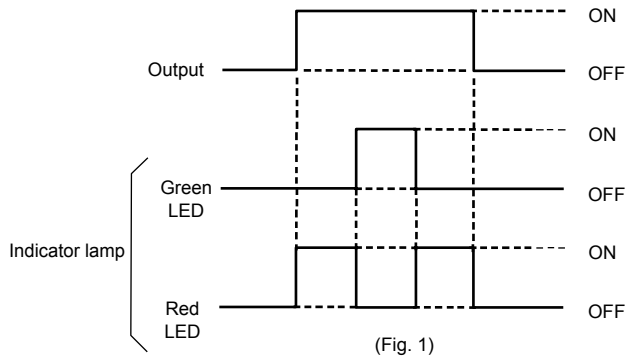

Internal circuit diagram

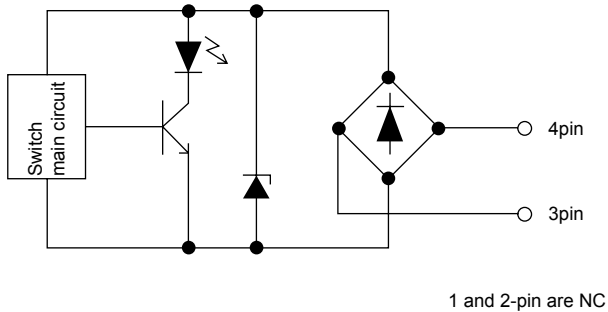

Dimensions

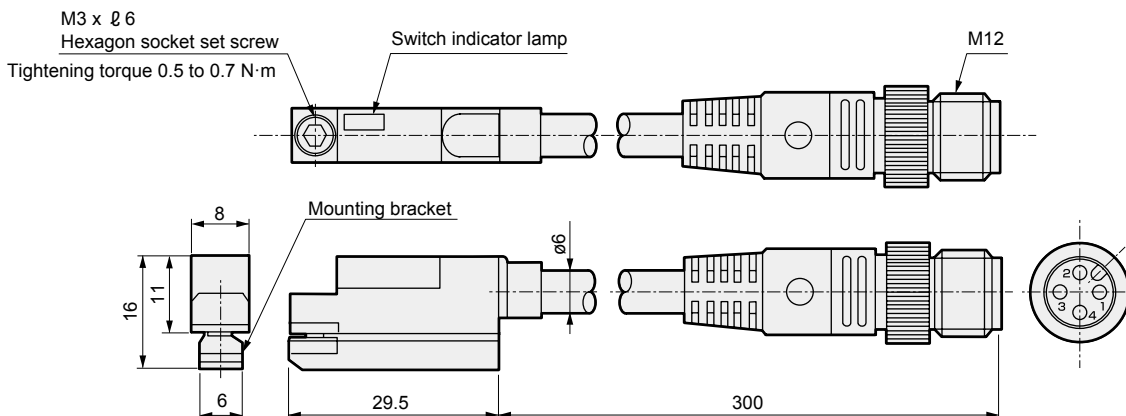

T type switch mounting and travel method

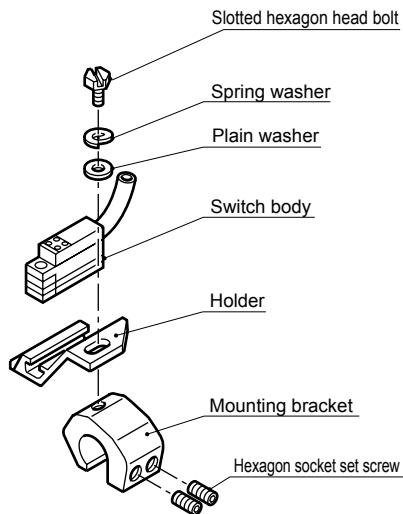

Mounting method

- (1) Pass the plain and spring washers through the slotted hexagon head bolt, and fit it onto the holder.
- (2) Fit the bracket onto the cylinder tie rod and tighten the hexagon socket head cap screw. Tightening torque is 0.5 to 0.7 N·m.
- (3) Lastly, tighten the hexagon socket set screw. Tightening torque is 1.7 to 2.0N·m.

Travel method

- (1) Fine adjustment
Loosen the slotted hex socket bolt, move only the switch body, and fix at the required position. Tightening torque is 0.5 to 0.7 N·m.
- (2) Rough adjustment
Completely loosen the slotted bolt and set screws, and move the entire mounting bracket to the required position. Tighten the slotted bolt. Tightening torque is 0.5 to 0.7 N·m.
Then tighten the set screw. Tightening torque is 1.7 to 2.0N·m.

H type switch mounting and travel method

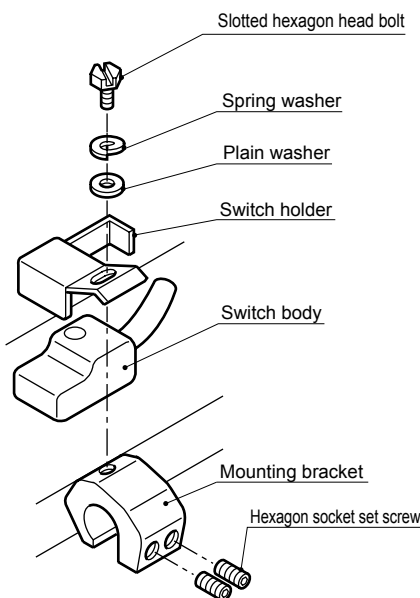

Mounting method

- (1) Pass the plain and spring washers through the slotted hexagon head bolt, and fit the bracket onto the switch holder slot.
- (2) Fit the bracket onto the cylinder tie rod and tighten the hexagon socket head cap screw. Tightening torque is 1.5 to 1.9N·m.
- (3) Lastly, tighten the set screw. Tightening torque is 1.7 to 2.0N·m.

Travel method

- (1) Fine adjustment
Loosen the slotted hex socket bolt of the switch holder, move only the switch body, and fix at the required position. Tightening torque is 1.5 to 1.9N·m.
- (2) Rough adjustment
Completely loosen the slotted bolt and set screws, and move the entire mounting bracket to the required position. Tighten the slotted bolt. Then tighten the set screw. Tightening torque is 1.7 to 2.0N·m.

LCM
LCR
LCG
LCW
LCX
STM
STG
STS/STL
STR2
UCA2
ULK*
JSK/M2
JSG
JSC3/JSC4
USSD
UFCD
USC
UB
JSB3
LMB
LML
HCM
HCA
LBC
CAC4
UCAC2
CAC-N
UCAC-N
RCS2
RCC2
PCC
SHC
MCP
GLC
MFC
BBS
RRC
GRC
RV3*
NHS
HRL
LN
Hand
Chuk
MechHnd/Chuk
ShkAbs
FJ
FK
SpdContr
Ending