



Moisture indicator

6119-2C Series

For dew point monitor of desiccant air dryer.

● Port size: Rc 1/4



Specifications

Item	6119-2C	
Max. working pressure	MPa	1.0 (≈150 psi, 10 bar)
Proof pressure	MPa	1.5 (≈220 psi, 15 bar)
Fluid temperature	°C	5 (41°F) to 65 (149°F)
Max. inlet air temperature	°C	32 (89.6°F)
Max. flow rate	ℓ /min(ANR)	50
Port size	Rc	1/4
Weight	kg	0.2

Internal structure and parts list

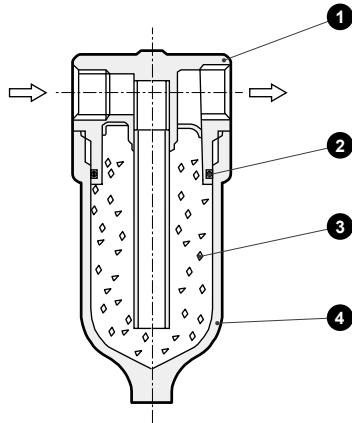

No.	Main part	6119
1	Body	Zinc die casting

Parts list

No.	Part name	Material	Model No.
2	O-ring	Special nitrile rubber	A1019-ORING
3	Silica gel	Silica gel	6119-SILICA-GEL(20g)
4	Bowl	Polycarbonate	A3019-BOWL

Dimensions

6119-2C

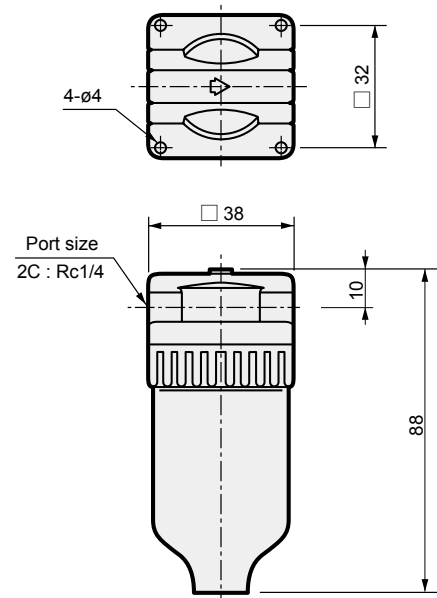

● Wall bracket: 6506

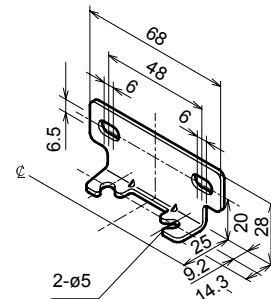

* Tapping screw attached

Operational principle

Through the moisture indicator, the dew point of ultra-dry air is monitored using the chemical properties of silica gel whose color changes from blue to pink after moisture is absorbed. If relative humidity in compressed air reaches 50%, the color changes to orange, so maintenance of the desiccant air dryer is easy.

⚠ Safety precautions

Avoid using in a place where the working air flow can increase or decrease vigorously or where the max. flow rate is exceeded.

The silica gel could flow to the secondary side.

F.R.L.
F.R.
F (Filtr)
R (Reg)
L (Lub)
Drain Separ
Mech Press SW
Res press exh valve
SlowStart
Anti-bac/Bac-remove Filtr
Film Resist FR
Oil-ProhR
Med Press FR
No Cu/ PTFE FRL
Outdrs FRL
Adapter Joiner
Press Gauge
CompFRL
LgFRL
PrecsR
VacF/R
Clean FR
ElecPneuR
AirBoost
Speed Ctrl
Silncr
CheckV/ other
Fit/Tube
Nozzle
Air Unit
PrecsCompn
Electro Press SW
ContactSW
AirSens
PresSW Cool
Air Flo Sens/Ctrl
WaterRISens
TotAirSys (Total Air)
TotAirSys (Gamma)
Gas generator
RefrDry
DesicDry
HiPolymDry
MainFiltr
Dischrg etc
Ending