



Air tank (related products)

AT Series

JIS symbol



Features

Air tank directly connected to air booster ABP-12 with compact body.

Specifications

Item	AT
Working fluid	Compressed air
Max. working pressure MPa	0.99 (≈140 psi, 9.9 bar)
Water pressure test pressure MPa	1.5 (≈220 psi, 15 bar)
Ambient temperature °C	0 (32°F) to 50 (122°F) (no freezing)
Internal capacity m ³	0.024
Port size	Rc1/2
Material	Steel
Weight kg	17.5

Note: O-ring, hexagon head bolt and spring washer are included for air booster mounting.

How to order

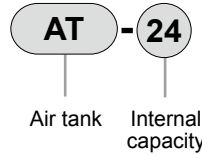

- Part model No.
- AT-K1 (O-ring, hex head bolt, spring washer)

Dimensions

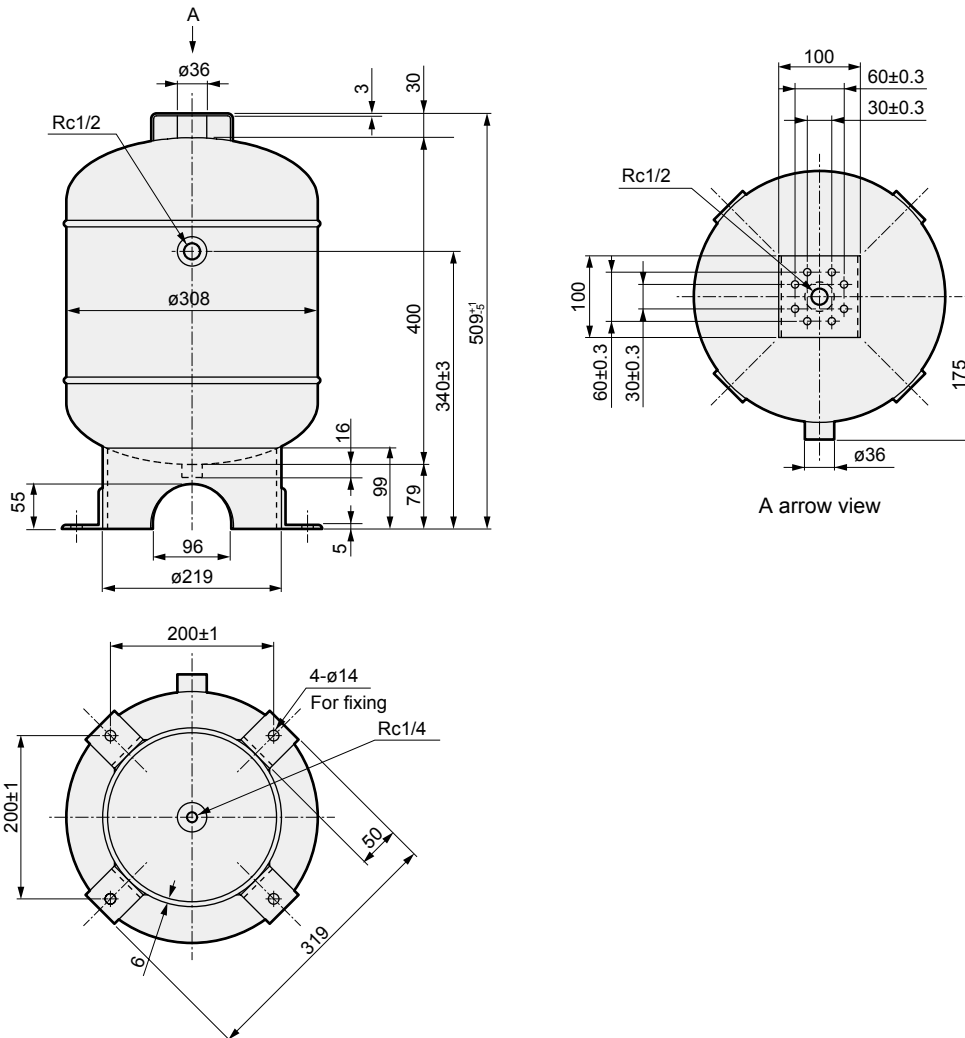

- F.R.L.
- F.R.
- F (Filtr)
- R (Reg)
- L (Lub)
- Drain Separ
- Mech Press SW
- Res press exh valve
- SlowStart
- Anti-bac/Bac-remove Filtr
- Film Resist FR
- Oil-ProhR
- Med Press FR
- No Cu/ PTFE FRL
- Outdrs FRL
- Adapter Joiner Press Gauge
- CompFRL
- LgFRL
- PreclsR
- VacF/R
- Clean FR
- ElecPneuR
- AirBoost**
- Speed Ctrl
- Silncr
- CheckV/ other
- Fit/Tube
- Nozzle
- Air Unit
- PreclsCompn
- Electro Press SW
- ContactSW
- AirSens
- PresSW Cool
- Air Flo Sens/Ctrl
- WaterRISens
- TotAirSys (Total Air)
- TotAirSys (Gamma)
- Gas generator
- RefrDry
- DesicDry
- HiPolymDry
- MainFiltr Dischrg etc
- Ending