

Air booster(Air booster)

ABP2-HP1 Series

JISCode

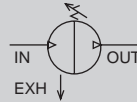

Specifications

Item	ABP2-HP1
Working fluid	Compressed air
Max. working pressure MPa	0.99
Min. working pressure MPa	0.2
Set pressure MPa	From a primary pressure of +0.1MPa to twice the primary pressure (max. 0.99MPa)
Proof pressure MPa	1.5
Flow rate m ³ /min(ANR)	Refer to the flow characteristics in the graph on the right
Boosting ratio	Max. twice (or equivalent)
Ambient temperature°C	0 to 50 (no freezing)
Lubrication	Not available
Port size	Rc1/4 (bottom, back Rc1/8)
Weight kg	2.0
Durability	10 million cycles(Nominal) (Refer to page 2)

[Example of model No.]

ABP2-02R-GSN-HP1

Model: Air booster

- **A** Body piping thread: Rc thread
- **B** Pressure gauge option: Pressure gauge (2 included)
- **C** Silencer option: Silencer (2 pcs. included)
- **D** Bracket option: None

How to order

ABP2-02R-N-N-N-HP1

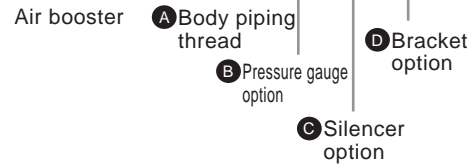

Code	Description
A Body port thread	
R	Rc thread
N	NPT thread (made to order) *1
G	G thread (made to order) *1

B Pressure gauge option	
N	No
G	Pressure gauge (2 included)

C Silencer option	
N	No
S	Silencer (2 pcs. included)
H	High performance silencer (2 pcs. included)

D Bracket option	
N	No
B	Foot bracket (2 included)
T	Tank mounting base (included)

*1: IN, OUT gauge port, and EXH port are Rc threads

Functions

- Primary pressure from IN passes through the check valve on IN side, and flows into booster chambers A and B. The primary pressure passes through the pressure adjustment section and switching valve, and flows into the driving chamber A. The piston moves to the left due to the pressure of the driving chamber A. Air in booster chamber A is compressed, passes through the check valve on the OUT side, and goes to the OUT side.
- When the piston reaches the stroke end, the changeover switch will be pushed, causing compressed air to be supplied to the switching valve pilot chamber and causing the switching valve to change over. Then the air in drive chamber A is exhausted, and the air is delivered to drive chamber B.
- Therefore, the piston moves to the right and air in booster chamber B is compressed, then passes through the check valve at the OUT side and moves OUT.
- If the above operations are repeated, pressure will be increased on the OUT side. Feedback pressure is transmitted to the pressure adjustment section due to the OUT side pressure, and boosting is continued until the pressure adjustment spring pressure is balanced.

Internal air circuit diagram

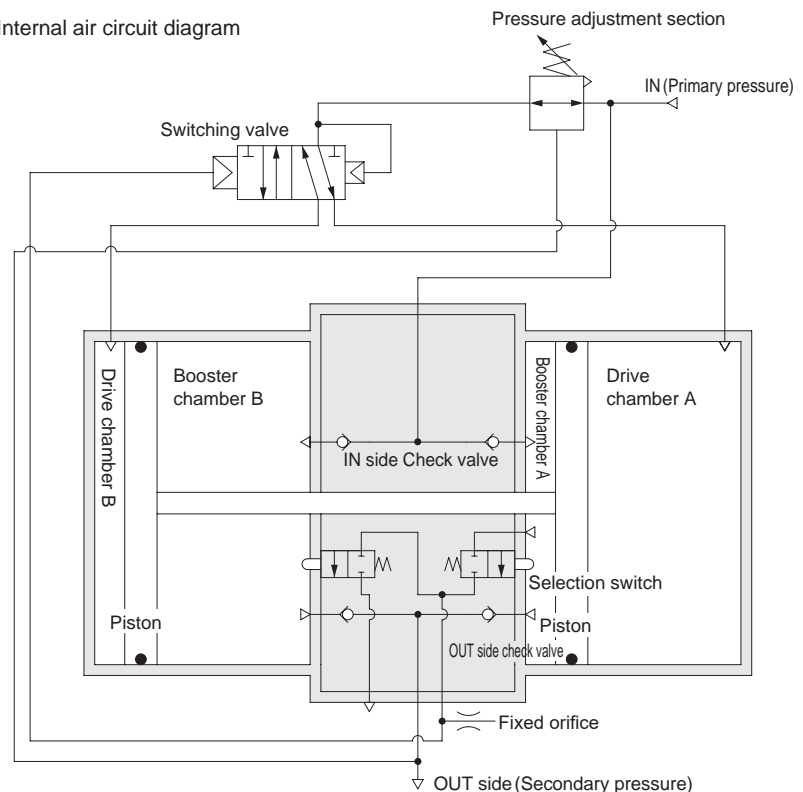

Flow characteristics

(with the 5 L air tank, equivalent to double the pressure increase)

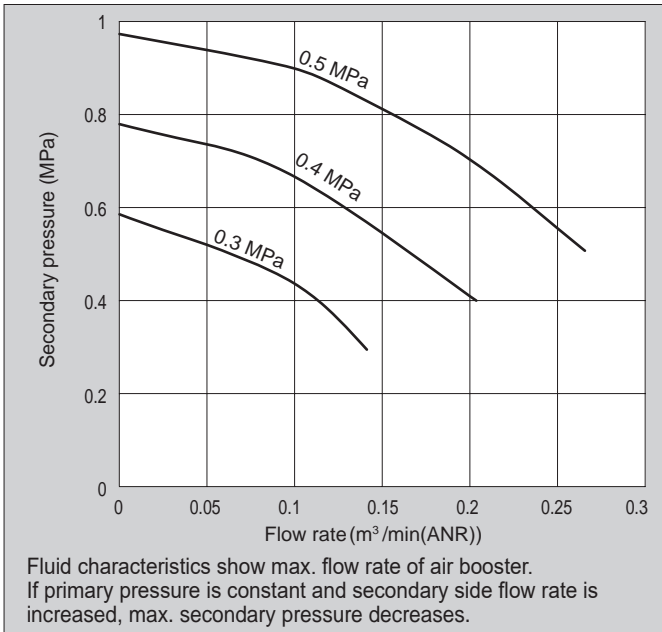

Pressure characteristics

(Setting: Primary pressure: 0.7MPa Secondary pressure: 0.99MPa Flow rate: 0.02m³/min (ANR))

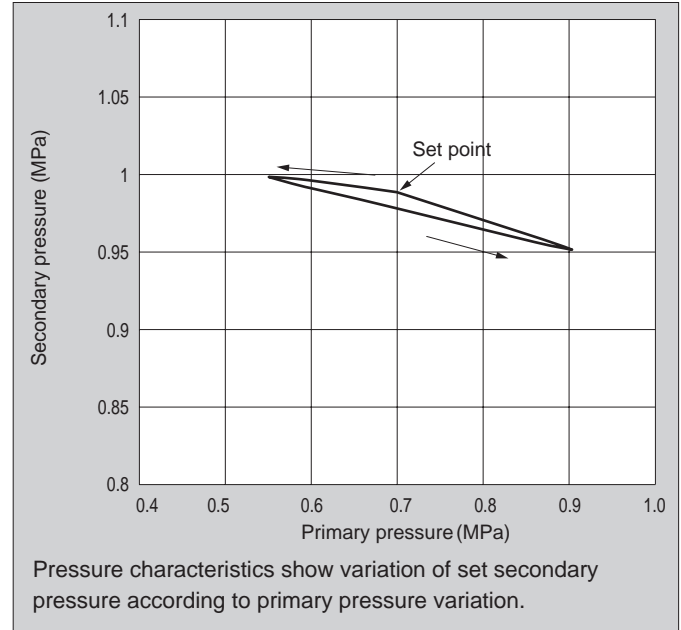

Note: Air booster needs approx. twice secondary side flow rate (max.) for primary side due to structure. Confirm that the instantaneous flow rate is within the curve.

Filling characteristics (when the boosting ratio is equivalent to twice)

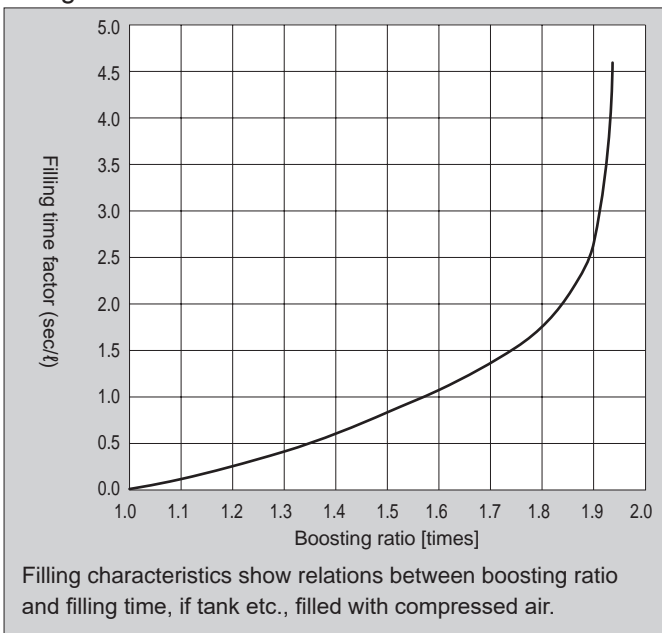

Pulsation

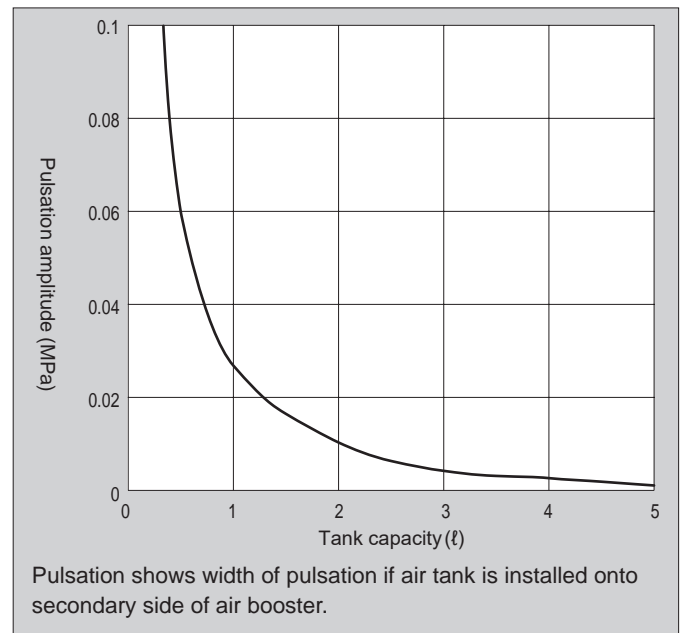

The time required to fill the tank with air can be calculated as follows. With the primary side pressure P_0 , inner tank pressure before filling P_1 , inner tank pressure after filling P_2 , pre-filling ratio between primary side pressure and inner tank pressure k_1 , and post-filling ratio between primary side pressure and inner tank pressure k_2 , the formula will be $k_1 = \frac{P_1}{P_0}$, $k_2 = \frac{P_2}{P_0}$. Calculate k_1 and k_2 , find the filling time factors t_1 and t_2 at the boosting ratio points k_1 and k_2 in the graph and substitute the values into $t = (t_2 - t_1)A$ to obtain the filling time t of the tank capacity A (l).

Formula for air booster operational cycle

$$N = \frac{Q \times 10^3}{0.95P + 0.096}$$

N: Operational cycle
Q: Required flow rate (m³/min(ANR))
P: Primary pressure (MPa)

Formula for air booster service life

The nominal life of the operational cycle is, in 10 million cycles

$$T = \frac{10,000,000}{N \times 60}$$

T: Service life (Time)

The characteristics above are typical examples, not guaranteed values.

ABP2-HP1 Series

Internal structure

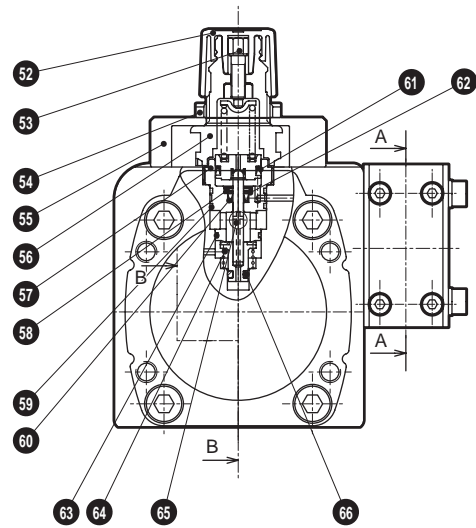
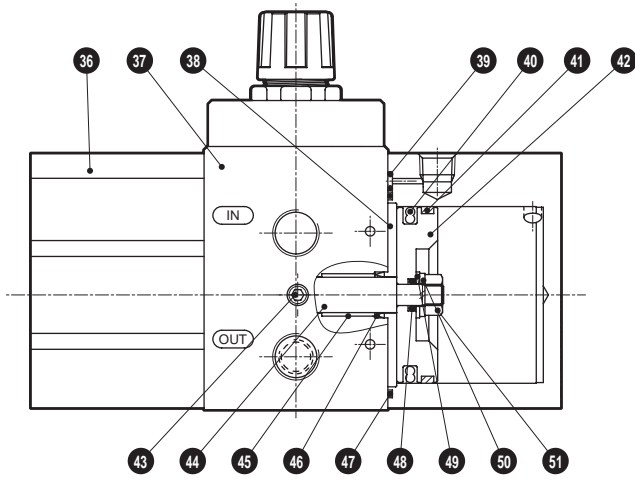
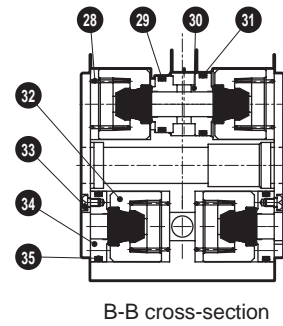
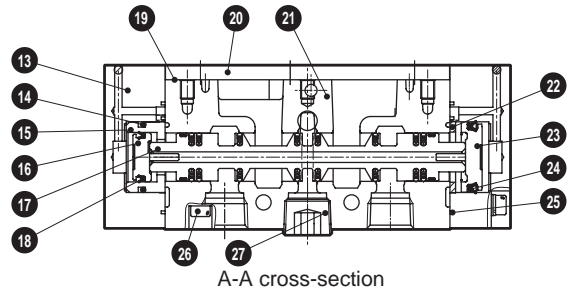
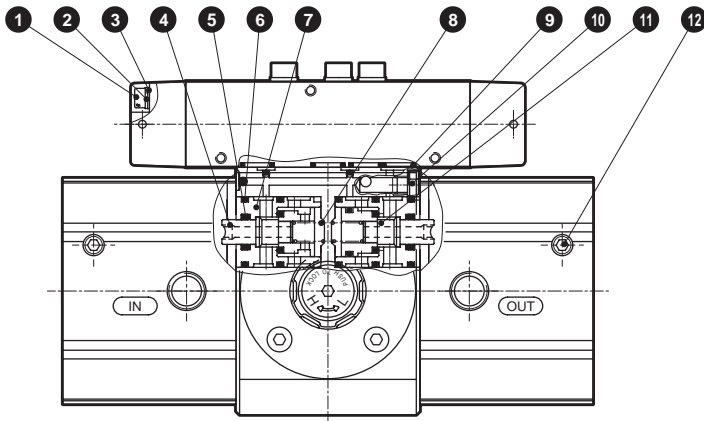

Parts list

Part number	Part name	Material	Part number	Part name	Material
1	Hexagon socket head cap screw	Stainless steel	34	Valve seat	Aluminum alloy
2	Spring washer	Stainless steel	35	O-ring	Nitrile rubber
3	Flat washer	Stainless steel	36	Cylinder body	Aluminum alloy
4	Valve bar	Stainless steel	37	Body	Aluminum alloy
5	Packing	Nitrile rubber	38	Side plate	Aluminum alloy
6	O-ring	Nitrile rubber	39	O-ring	Nitrile rubber
7	Detection valve body	Aluminum alloy	40	Packing	Nitrile rubber
8	Spring	Steel	41	Wear ring	Resin
9	O-ring	Nitrile rubber	42	Piston	Aluminum alloy
10	Fixed orifice	Aluminum alloy	43	Hexagon socket set screw	Stainless steel
11	Valve bar	Stainless steel	44	Piston rod	Stainless steel
12	Hexagon socket set screw	Stainless steel	45	Bush	Oiles drymet
13	Pilot cap	Resin	46	Packing	Nitrile rubber
14	O-ring	Nitrile rubber	47	O-ring	Nitrile rubber
15	Valve piston spacer	Aluminum alloy	48	O-ring	Nitrile rubber
16	Piston	Resin	49	Flat washer	Stainless steel
17	Spool assembly	-	50	Spring washer	Stainless steel
18	Packing	Nitrile rubber	51	Hexagon nut	Stainless steel
19	Adaptor gasket	Nitrile rubber	52	Knob	Resin
20	Adapter	Aluminum alloy	53	Regulator piston assembly	-
21	Valve body	Aluminum alloy	54	Nut	Resin
22	Valve piston spacer	Aluminum alloy	55	Cover holder	Aluminum alloy
23	Piston	Resin	56	Cover	Aluminum alloy
24	Packing	Nitrile rubber	57	Stem holder	Aluminum alloy
25	Gasket	Nitrile rubber	58	CR ring	Stainless steel
26	Hexagon socket head cap screw	Stainless steel	59	O-ring	Nitrile rubber
27	Plug	Steel	60	Packing	Nitrile rubber
28	Spring	Steel	61	Packing	Nitrile rubber
29	O-ring	Nitrile rubber	62	Cap	Stainless steel
30	Valve seat	Aluminum alloy	63	O-ring	Nitrile rubber
31	O-ring	Nitrile rubber	64	Spring	Steel
32	Check valve assembly	-	65	Valve assembly	-
33	Cross-recessed pan head machine screw	Stainless steel	66	O-ring	Nitrile rubber

Optional parts individual list

Part name	Model No.	Remarks
Bracket	ABP2-02-B	Qty per unit
Base for mounting tank	ABP2-02-T	Hexagon socket head cap screw for tank mounting, O-ring included
Pressure gauge	G29D-6-P15	Pressure gauge x 1
Silencer	SLW-8S-2PC	Silencer x 2
High performance silencer	SLW-8A-H-2PC	Silencer x 2

ABP2-HP1 Series

Dimensions



● ABP2-02-HP1

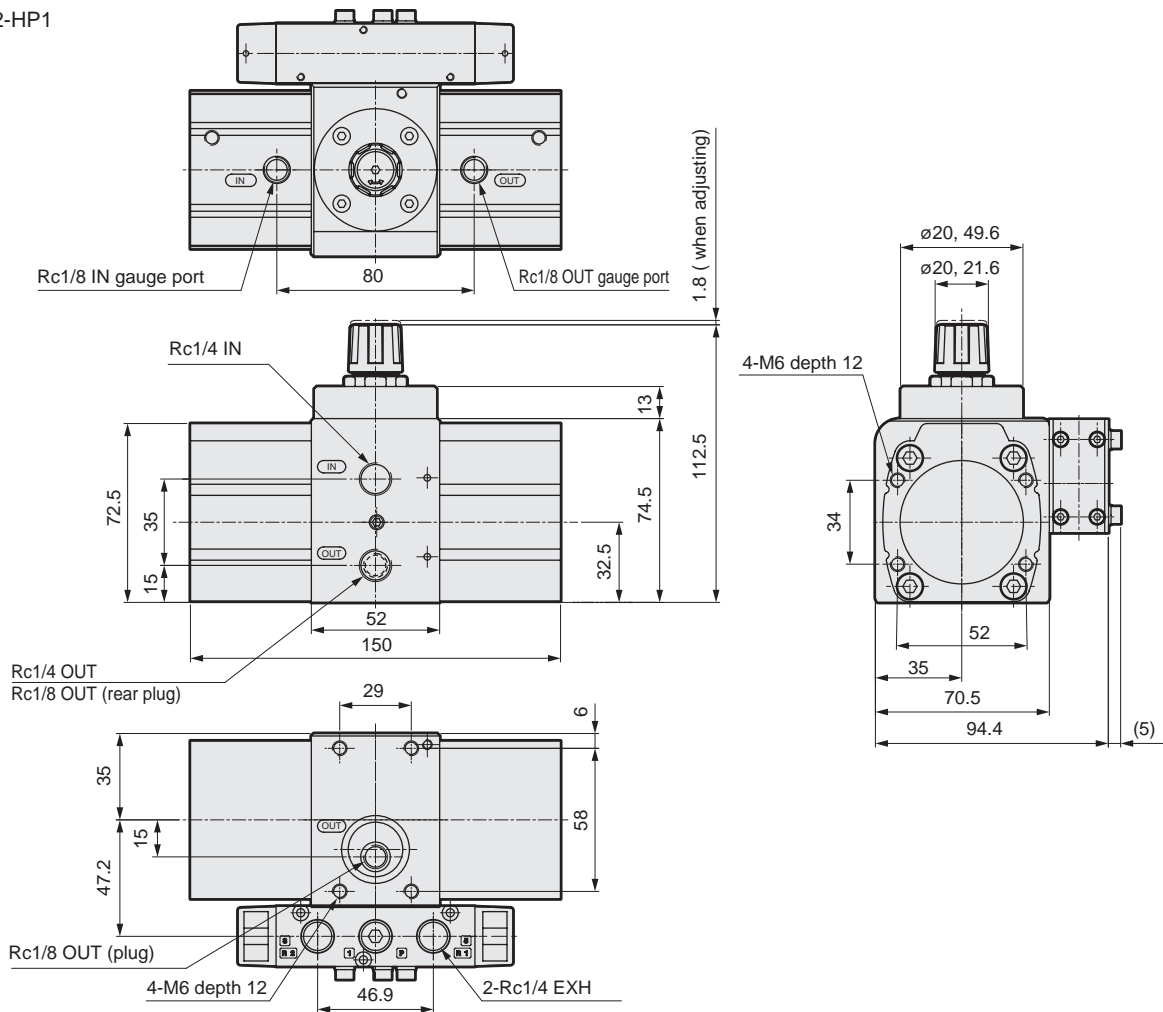

Optional dimensions

● When mounting pressure gauge/silencer/bracket

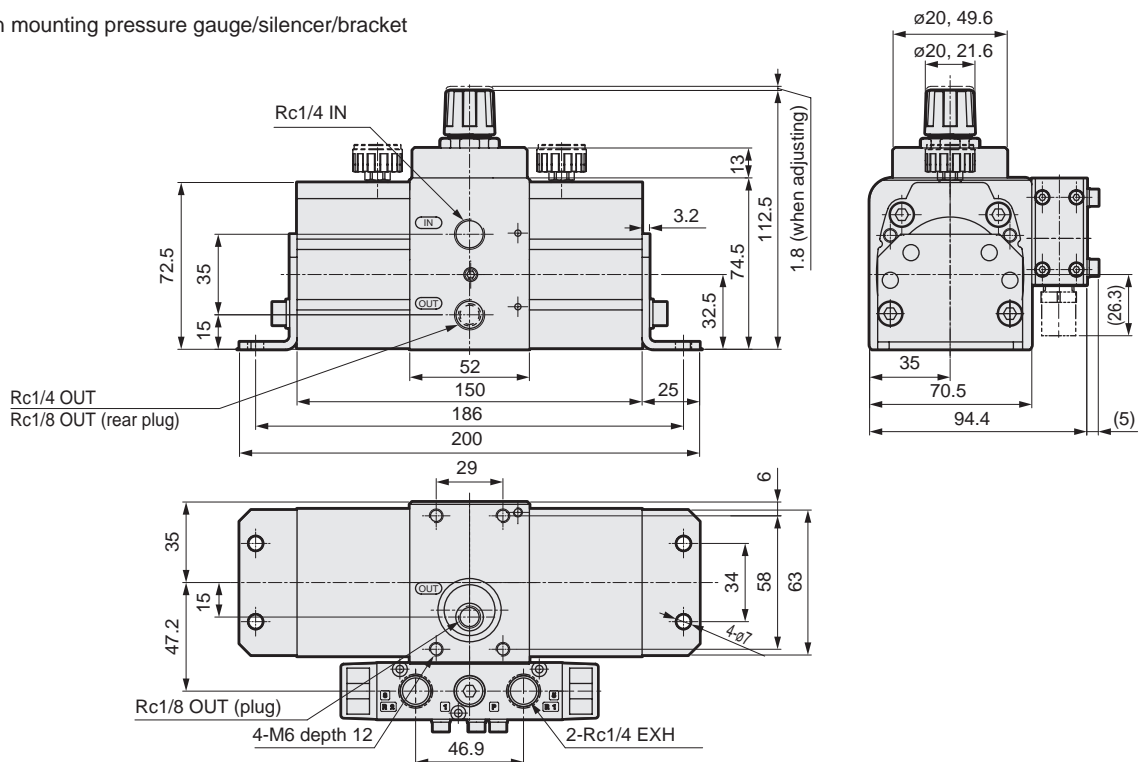

Optional dimensions



- When mounting pressure gauge, high noise reduction silencer and bracket

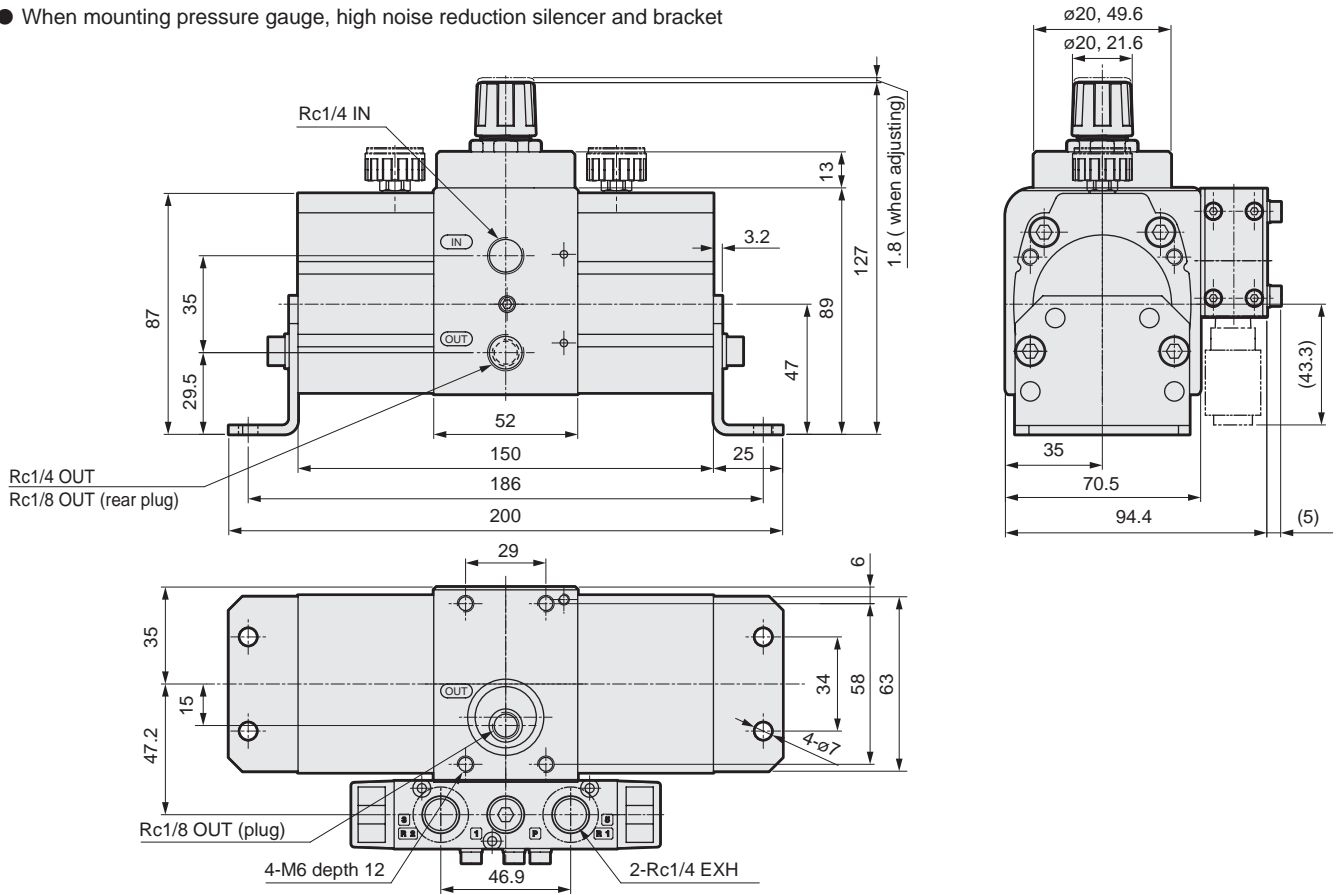

Optional dimensions

- When mounted on the back of the bracket

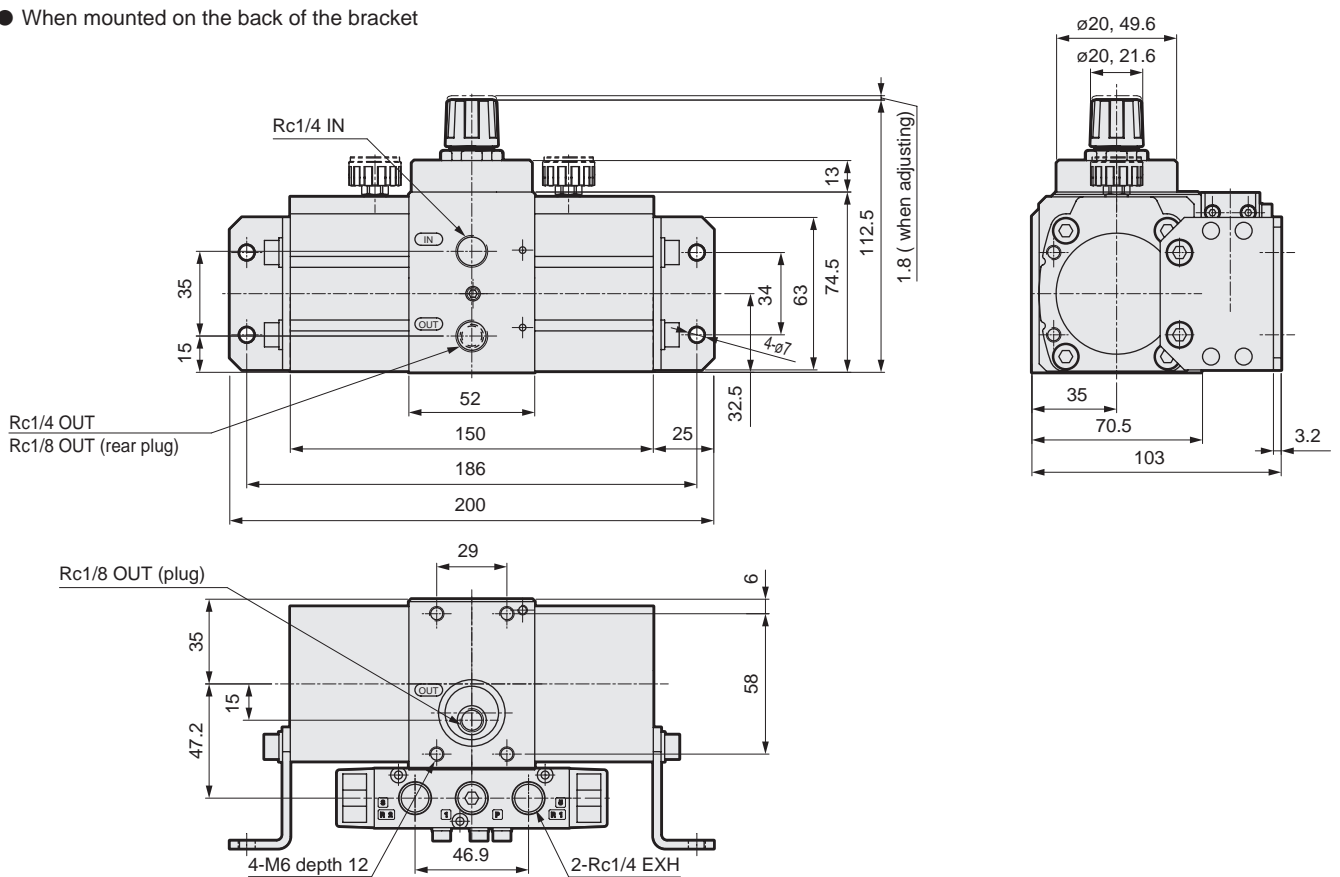

ABP2-HP1 Series

Optional dimensions



- When mounting the tank mounting base

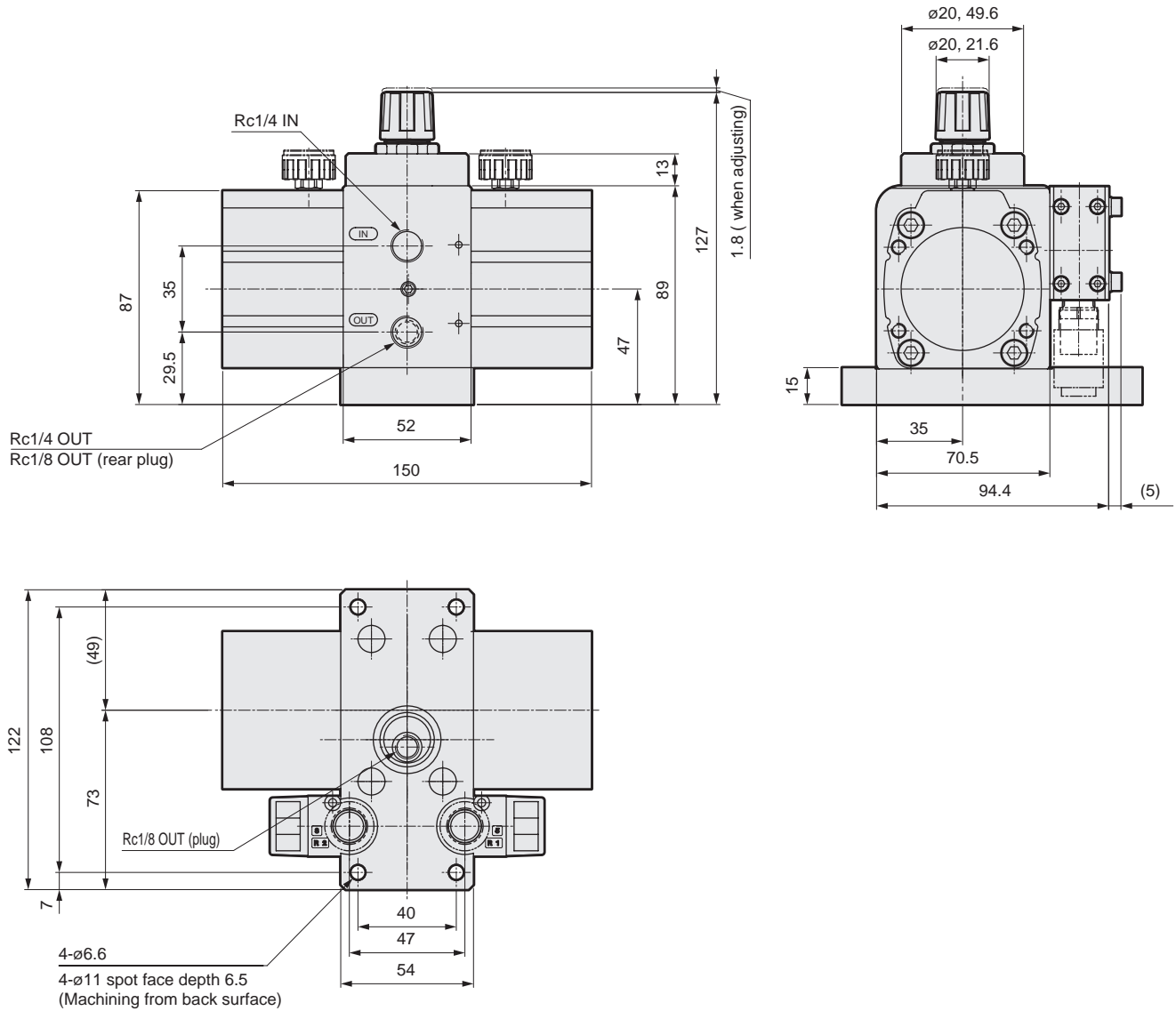

Optional dimensions

- Pressure gauge (G29D-6-P15)

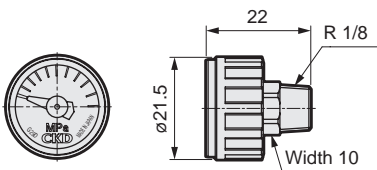

- Silencer (SLW-8S)

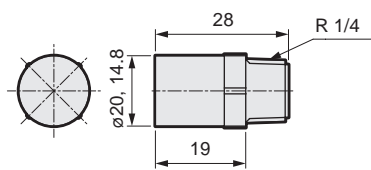

- High noise reduction silencer (SLW-8A-H)

