

LCM
LCR
LCG
LCW
LCX
STM
STG
STS/STL
STR2
UCA2
ULK*
JSK/M2
JSG
JSC3/JSC4
USSD
UFCD
USC
UB
JSB3
LMB
LML
HCM
HCA
LBC
CAC4
UCAC2
CAC-N
UCAC-N
RCS2
RCC2
PCC
SHC
MCP
GLC
MFC
BBS
RRC
GRC
RV3*
NHS
HRL
LN
Hand
Chuk
MecHnd/Chuk
ShkAbs
FJ
FK
SpdContr
Ending
LSH-HP
LSH
FH100
BSA2
BHA/BHG
LHA
LHAG
HAP
HKP
HCP
HGP
HLF2
HLA/HLB
HLAG/HLBG
HLC
HLD
HMF
HMF-G
HMFB
HFP
FH500
HBL
HJL
HMD
HDL
HJD
BHE

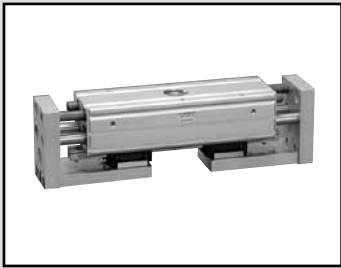

Linear guided large wide parallel hand
(Long stroke 1/long stroke 2)

HMFB Series

● Operational stroke length: Long stroke 1 100, 120, 160
Long stroke 2 120, 160, 200

Double acting



Specifications

Item	HMFB					
	25CS		32CS		40CS	
Size	L1	L2	L1	L2	L1	L2
Bore size mm	ø25×2		ø32×2		ø40×2	
Working fluid	Compressed air					
Max. working pressure MPa	0.7 (≈100 psi, 7 bar)					
Min. working pressure MPa	0.3 (≈44 psi, 3 bar)					
Ambient temperature °C	5 (41°F) to 60 (140°F)					
Port size	M5			Rc1/8		
Operating stroke length mm	100	120	120	160	160	200
Rod diameter mm	ø12		ø16		ø20	
Volumetric capacity (reciprocating) cm ³	75.4	90.5	145	193	301	377
Repeatability mm	±0.1					
Weight kg	4.06	4.13	5.97	7.2	10.05	11.8
Lubrication	Not required (use turbine oil class 1 ISO VG32 if necessary for lubrication)					

Switch specifications

Item	Proximity 2-wire	Proximity 3-wire
	T2H/T2V	T3H/T3V
Applications	Dedicated for programmable controller	For programmable controller, relay
Output method	-	NPN output
Power supply voltage	-	10 to 28 VDC
Load voltage/current	10 to 30 VDC, 5 to 20 mA (*1)	30 VDC, 100 mA or less
Indicator lamp	LED (Lit when ON)	
Leakage current	1 mA or less	10 µA or less
Weight	1 m:18 g 3 m:49 g 5 m:80 g	

*1 : The above max. load current is 20 mA at 25°C.

The current is lower than 20 mA if the operating ambient temperature around the switch is higher than 25°C. (5 to 10 mA at 60°C)

*2 : Refer to Ending Page 1 for detailed switch specifications and dimensions.

How to order

Without switch (built-in magnet for switch)

HMFB - 25CS - L1

With switch (built-in magnet for switch)

HMFB - 25CS - L1 - T2H - R

A Size

B Option

C Switch model No.
* indicates the lead wire length.

D Switch quantity

Code	Description				
A Size					
25CS					
32CS					
40CS					
B Option					
L1	Long stroke 1				
L2	Long stroke 2				
C Switch model No.					
Axial lead wire	Radial lead wire	Contact	Voltage	Display	Lead wire
			AC	DC	
T2H*	T2V*	Proximity	●	1-color	2-wire
T3H*	T3V*		●	display	3-wire
* Lead wire length					
Blank	1 m (standard)				
3	3 m (option)				
5	5 m (option)				
D Switch quantity					
R	1 on open side				
H	1 on closed side				
D	2				

[Example of model No.]

HMFB-25CS-L1-T2H-R

Model: Linear guided large wide parallel hand

- A** Size : 25CS
- B** Option : Long stroke 1
- C** Switch model No.: Proximity T2H switch, lead wire 1 m
- D** Switch quantity : 1 on open side

How to order switch

SW - T2H

Switch model No.
(Item **C** above)

LCM
LCR
LCG
LCW
LCX
STM
STG
STS/STL
STR2
UCA2
ULK*
JSK/M2
JSG
JSC3/JSC4
USSD
UFCD
USC
UB
JSB3
LMB
LML
HCM
HCA
LBC
CAC4
UCAC2
CAC-N
UCAC-N
RCS2
RCC2
PCC
SHC
MCP
GLC
MFC
BBS
RRC
GRC
RV3*
NHS
HRL
LN
Hand
Chuk
MechHnd/Chuk
ShkAbs
FJ
FK
SpdContr
Ending
LSH-HP
LSH
FH100
BSA2
BHA/BHG
LHA
LHAG
HAP
HKP
HCP
HGP
HLF2
HLA/HLB
HLAG/HLBG
HLC
HLD
HMF
HMFB
HMF-G
HFP
FH500
HBL
HJL
HMD
HDL
HJD
BHE

Internal structure and parts list

- HMFB-25CS to 40CS-L1
- HMFB-25CS to 40CS-L2

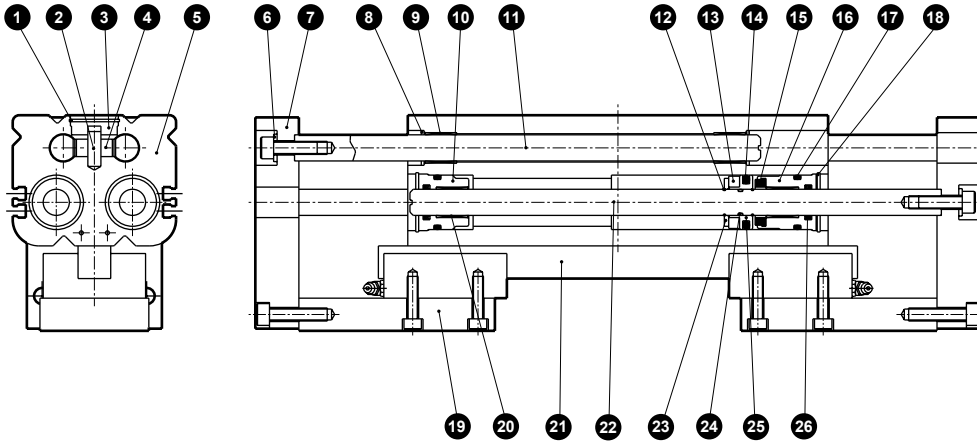

Cannot be disassembled

Parts list

No.	Part name	Material	Remarks	No.	Part name	Material	Remarks
1	C type snap ring	Stainless steel		14	Packing	Nitrile rubber	
2	Pinion gear axis	Stainless steel		15	Cushion	Urethane rubber	
3	Pinion cover	Stainless steel		16	Cylinder guard A	Aluminum alloy	
4	Pinion gear	Carbon steel		17	O-ring	Nitrile rubber	
5	Body	Aluminum alloy		18	C type snap ring	Stainless steel	
6	Plain washer	Stainless steel	32CS-L1, L2 are not available	19	Connection plate	Aluminum alloy	
7	Finger	Aluminum alloy		20	Bush	Sintering oil impregnated alloy	
8	Needle bearing sealant			21	LM guide		
9	Bush	Sintering oil impregnated alloy		22	Piston rod	Stainless steel	
10	Cylinder guard B	Aluminum alloy		23	Magnet holder	Stainless steel	
11	Guide rod	Stainless steel		24	O-ring	Nitrile rubber	
12	Piston fixing spring	Stainless steel		25	Piston	Stainless steel	
13	Magnet			26	Packing	Nitrile rubber	

Gripping power performance data

- Gripping power represents the thrust (per one finger) in the arrow direction shown in the figure.
- The gripping power at a supply pressure 0.3, 0.5, and 0.7 MPa with finger length ℓ of hand is shown.
- Both open direction (←) and closed direction (→) (shown with continuous line)

(Note) When making a selection, read the precautions for design and selection on page 1764.

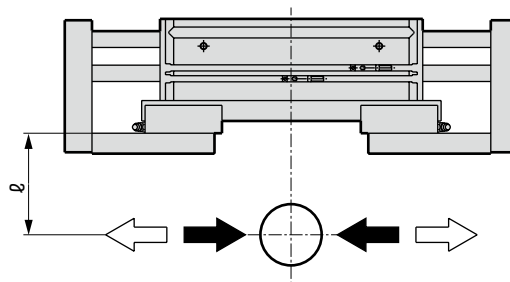

● HMFB-25CS

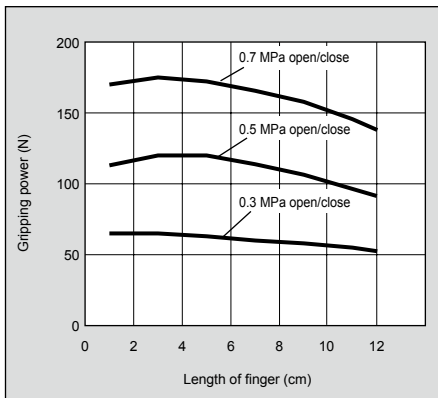

● HMFB-32CS

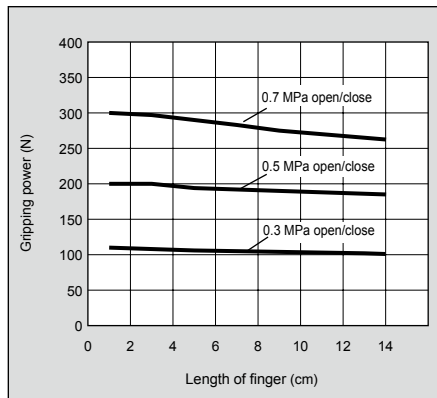

● HMFB-40CS

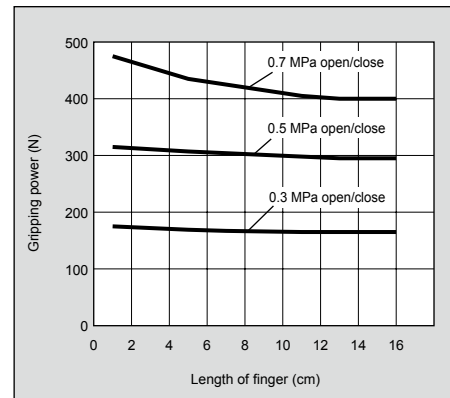

LCM
LCR
LCG
LCW
LCX
STM
STG
STS/STL
STR2
UCA2
ULK*
JSK/M2
JSG
JSC3/JSC4
USSD
UFCD
USC
UB
JSB3
LMB
LML
HCM
HCA
LBC
CAC4
UCAC2
CAC-N
UCAC-N
RCS2
RCC2
PCC
SHC
MCP
GLC
MFC
BBS
RRC
GRC
RV3*
NHS
HRL
LN
Hand
Chuk
MecHnd/Chuk
ShkAbs
FJ
FK
SpdContr
Ending
LSH-HP
LSH
FH100
BSA2
BHA/BHG
LHA
LHAG
HAP
HKP
HCP
HGP
HLF2
HLA/HLB
HLAG/HLBG
HLC
HLD
HMF
HMF-G
HMFB
HFP
FH500
HBL
HJL
HMD
HDL
HJD
BHE

Dimensions



● HMFB-25CS-L1/L2

● With switch

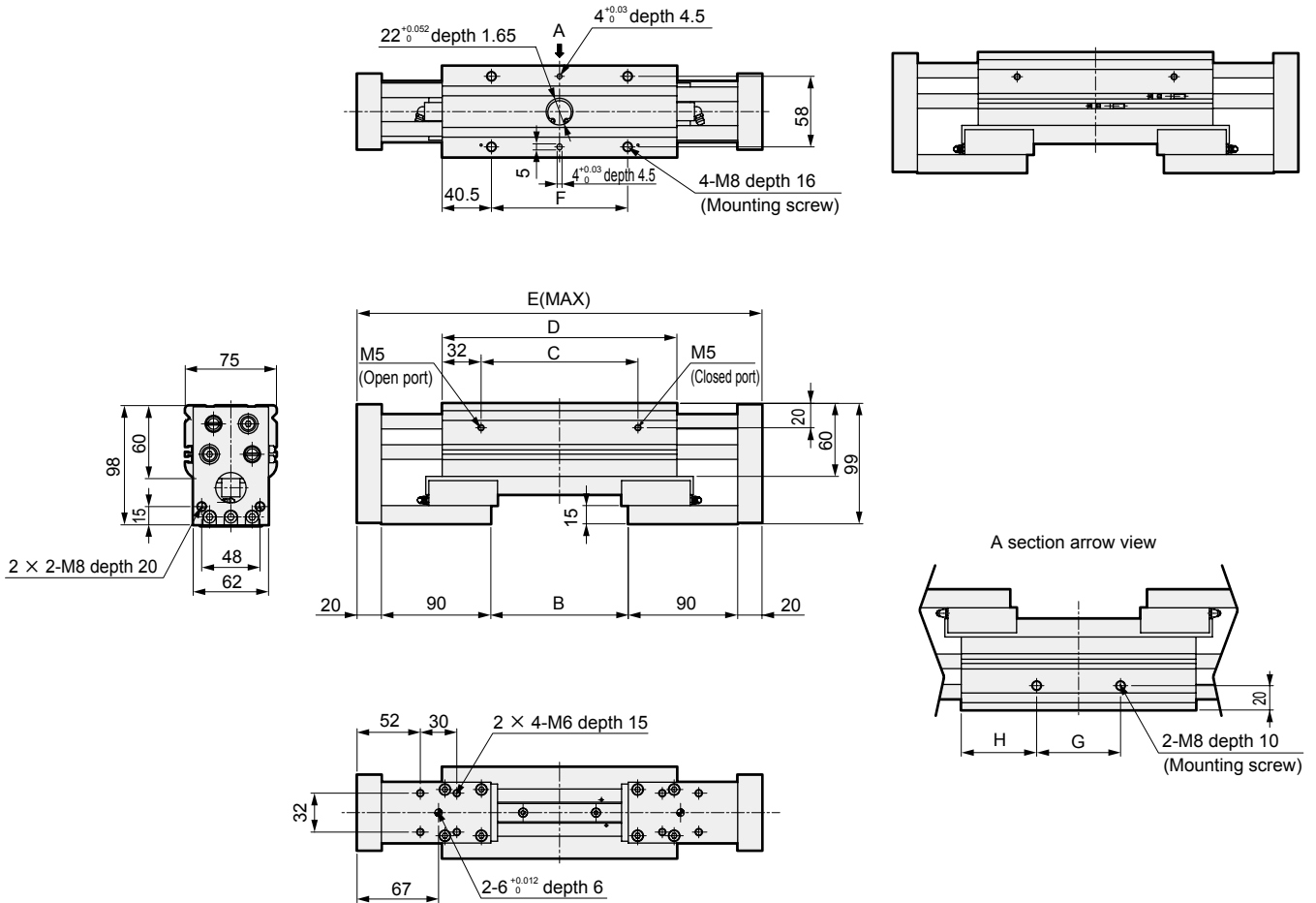

Code	B		C	D	E	F	G	H
	MAX	MIN						
L1	113	13	129	193	333	112	69	62
L2	131	11	127	191	351	110	87	52

LCM
LCR
LCG
LCW
LCX
STM
STG
STS/STL
STR2
UCA2
ULK*
JSK/M2
JSG
JSC3/JSC4
USSD
UFCD
USC
UB
JSB3
LMB
LML
HCM
HCA
LBC
CAC4
UCAC2
CAC-N
UCAC-N
RCS2
RCC2
PCC
SHC
MCP
GLC
MFC
BBS
RRC
GRC
RV3*
NHS
HRL
LN
Hand
Chuk
MechMod/Chuk
ShkAbs
FJ
FK
SpdContr
Ending
LSH-HP
LSH
FH100
BSA2
BHA/BHG
LHA
LHAG
HAP
HKP
HCP
HGP
HLF2
HLA/HLB
HLAG/HLBG
HLC
HLD
HMFB
HFP
FH500
HBL
HJL
HMD
HDL
HJD
BHE

HMFB Series

Dimensions



● HMFB-32CS-L1/L2

● With switch

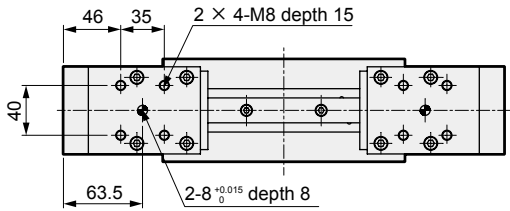
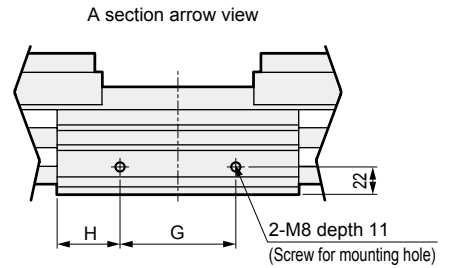
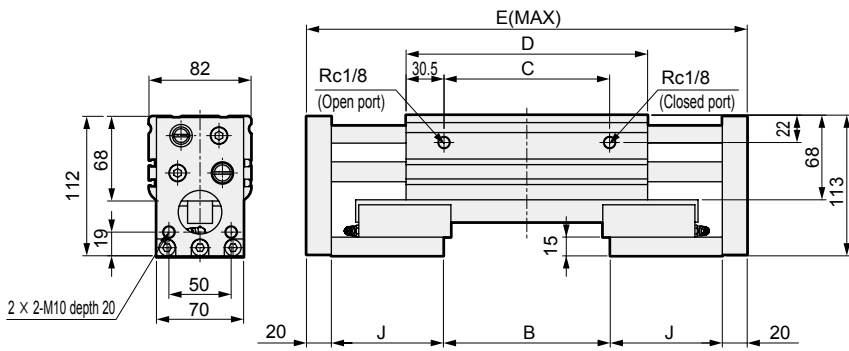
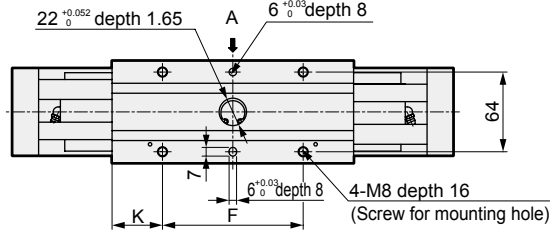

Code	B		C	D	E	F	G	H	J	K
	MAX	MIN								
L1	134	14	133	194	354	113	93	50.5	90	40.5
L2	174	14	193	254	454	167	133	60.5	120	43.5

- LCM
- LCR
- LCG
- LCW
- LCX
- STM
- STG
- STS/STL
- STR2
- UCA2
- ULK*
- JSK/M2
- JSG
- JSC3/JSC4
- USSD
- UFCD
- USC
- UB
- JSB3
- LMB
- LML
- HCM
- HCA
- LBC
- CAC4
- UCAC2
- CAC-N
- UCAC-N
- RCS2
- RCC2
- PCC
- SHC
- MCP
- GLC
- MFC
- BBS
- RRC
- GRC
- RV3*
- NHS
- HRL
- LN
- Hand**
- Chuk
- MecHnd/Chuk
- ShkAbs
- FJ
- FK
- SpdContr
- Ending
- LSH-HP
- LSH
- FH100
- BSA2
- BHA/BHG
- LHA
- LHAG
- HAP
- HKP
- HCP
- HGP
- HLF2
- HLA/HLB
- HLAG/HLBG
- HLC
- HLD
- HMF
- HMF-G
- HMFB**
- HFP
- FH500
- HBL
- HJL
- HMD
- HDL
- HJD
- BHE

Dimensions



● HMFB-40CS-L1/L2

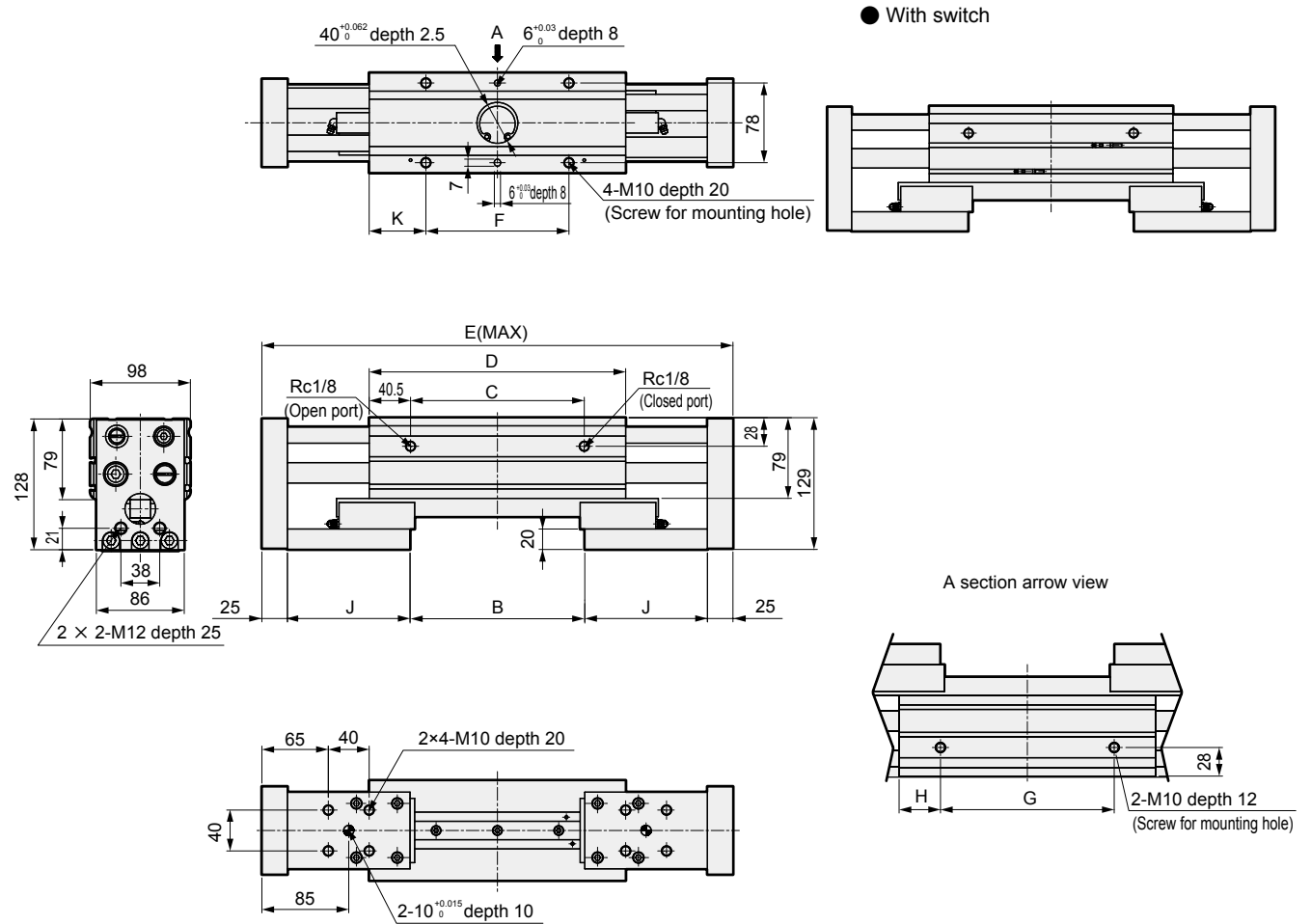

Code	B		C	D	E	F	G	H	J	K
	MAX	MIN								
L1	171	11	170	251	461	140	170	40.5	120	55.5
L2	214	14	233	314	564	202	160	77	150	56

LCM
LCR
LCG
LCW
LCX
STM
STG
STS/STL
STR2
UCA2
ULK*
JSK/M2
JSG
JSC3/JSC4
USSD
UFCD
USC
UB
JSB3
LMB
LML
HCM
HCA
LBC
CAC4
UCAC2
CAC-N
UCAC-N
RCS2
RCC2
PCC
SHC
MCP
GLC
MFC
BBS
RRC
GRC
RV3*
NHS
HRL
LN
Hand
Chuk
MechHnd/Chuk
ShkAbs
FJ
FK
SpdContr
Ending
LSH-HP
LSH
FH100
BSA2
BHA/BHG
LHA
LHAG
HAP
HKP
HCP
HGP
HLF2
HLA/HLB
HLAG/HLBG
HLC
HLD
HMF
HMFB
HMFB-G
HFP
FH500
HBL
HJL
HMD
HDL
HJD
BHE