



Thin long stroke parallel hand Double acting
(Standard/long stroke 1)

HLC Series

- Operating stroke length: Standard 20, 30, 40, 50, 60, 70
Long stroke 1 60, 80, 100, 120, 140

Double acting



Specifications

Item	HLC													
	08CS			12CS			16CS		20CS		25CS		30CS	
Size	Standard			L1			Standard		L1		Standard		L1	
Bore size mm	ø8×2			ø12×2			ø16×2		ø20×2		ø25×2		ø30×2	
Working fluid	Compressed air													
Max. working pressure MPa	0.7 (≈100 psi, 7 bar)													
Min. working pressure MPa	0.2 (≈29 psi, 2 bar)													
Ambient temperature °C	5 (41°F) to 60 (140°F)													
Port size	M3						M5							
Operating stroke length mm	20	30	60	40	80	50	100	60	120	70	140			
Volumetric capacity (reciprocating) cm ³	2.0	6.8	13.6	16.1	32.2	31.4	62.8	58.9	117.8	99	198			
Repeatability mm	±0.01						±0.03							
Weight kg	0.14	0.29	0.44	0.71	0.85	1.03	1.4	1.62	2.23	2.74	3.69			
Lubrication	Not required (use turbine oil class 1 ISO VG32 if necessary for lubrication)													

Switch specifications

Item	Proximity 2-wire	Proximity 3-wire
	T2H/V	T3H/V
Applications	Dedicated for programmable controller	For programmable controller, relay
Output method	-	NPN output
Power supply voltage	-	10 to 28 VDC
Load voltage/current	10 to 30 VDC, 5 to 20 mA (*1)	30 VDC or less, 100 mA or less
Indicator lamp	LED (Lit when ON)	
Leakage current	1 mA or less	10 µA or less
Weight	1 m:18 g 3 m:49 g 5 m:80 g	

*1 : The above max. load current is 20 mA at 25°C. The current is lower than 20 mA if the operating ambient temperature around the switch is higher than 25°C. (5 to 10 mA at 60°C)

*2 : Refer to Ending Page 1 for detailed switch specifications and dimensions.

HLC allowable load and allowable moment

Max load / moment	F	Mx	Mz	My
Model No.	N	N·m	N·m	N·m
HLC-08CS	102	10	8.5	1.6
HLC-12CS	151	11.9	8.2	4.68
HLC-12CS-L1	151	11.9	8.2	4.68
HLC-16CS	325	27.5	25.6	7.96
HLC-16CS-L1	325	27.5	25.6	10.6
HLC-20CS	306	29.9	27	10.6
HLC-20CS-L1	306	29.9	27	11.2
HLC-25CS	423	105.1	96.4	19.7
HLC-25CS-L1	423	105.1	96.4	19.7
HLC-30CS	694	109.3	116.5	33.3
HLC-30CS-L1	694	109.3	116.5	43.1

*The values above are static load and moment.

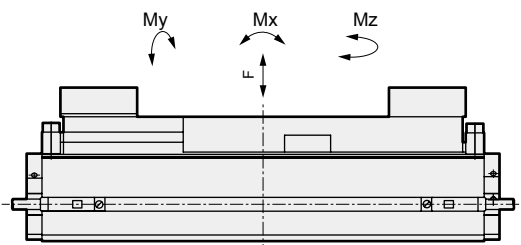

LCM
LCR
LCG
LCW
LCX
STM
STG
STS/STL
STR2
UCA2
ULK*
JSK/M2
JSG
JSC3/JSC4
USSD
UFCD
USC
UB
JSB3
LMB
LML
HCM
HCA
LBC
CAC4
UCAC2
CAC-N
UCAC-N
RCS2
RCC2
PCC
SHC
MCP
GLC
MFC
BBS
RRC
GRC
RV3*
NHS
HRL
LN
Hand
Chuk
MechHnd/Chuk
ShkAbs
FJ
FK
SpdContr
Ending
LSH-HP
LSH
FH100
BSA2
BHA/BHG
LHA
LHAG
HAP
HKP
HCP
HGP
HLF2
HLA/HLB
HLAG/HLBG
HLC
HLD
HMF
HMF-G
HMFB
HFP
FH500
HBL
HJL
HMD
HDL
HJD
BHE

How to order

Without switch (built-in magnet for switch)

HLC - 20CS - L1

With switch (built-in magnet for switch)

HLC - 20CS - L1 - T2H - R

A Size

B Option

C Switch model No.
* indicates the lead wire length.

D Switch quantity

[Example of model No.]

HLC-20CS-L1-T2H-R

Model: Thin long stroke parallel hand

- A** Size : 20CS
- B** Option : Long stroke 1
- C** Switch model No.: Proximity T2H switch, lead wire 1 m
- D** Switch quantity : 1 on open side

Code	Description						
A Size							
08CS							
12CS							
16CS							
20CS							
25CS							
30CS							
B Option							
	Size	08CS	12CS	16CS	20CS	25CS	30CS
Blank	Standard	●	●	●	●	●	●
L1	Long stroke 1		●	●	●	●	●
C Switch model No.							
Axial lead wire	Radial lead wire	Contact	Voltage		Display	Lead wire	
			AC	DC			
T2H*	T2V*	Proximity		●	1-color	2-wire	
T3H*	T3V*			●	display	3-wire	
* Lead wire length							
Blank	1 m (standard)						
3	3 m (option)						
5	5 m (option)						
D Switch quantity							
R	1 on open side						
H	1 on closed side						
D	2						

How to order switch

SW - T2H

Switch model No.
(Item **C** above)

Specifications for rechargeable battery (Catalog No. CC-1226A)

HLC - ... - P4* ● Design compatible with rechargeable battery manufacturing process.

* Contact CKD for details.

LCM
LCR
LCG
LCW
LCX
STM
STG
STS/STL
STR2
UCA2
ULK*
JSK/M2
JSG
JSC3/JSC4
USSD
UFCD
USC
UB
JSB3
LMB
LML
HCM
HCA
LBC
CAC4
UCAC2
CAC-N
UCAC-N
RCS2
RCC2
PCC
SHC
MCP
GLC
MFC
BBS
RRC
GRC
RV3*
NHS
HRL
LN
Hand
Chuk
MechHnd/Chuk
ShkAbs
FJ
FK
SpdContr
Ending
LSH-HP
LSH
FH100
BSA2
BHA/BHG
LHA
LHAG
HAP
HKP
HCP
HGP
HLF2
HLAG/HLBG
HLAG/HLBG
HLC
HLD
HMF
HMF-G
HMFB
HFP
FH500
HBL
HJL
HMD
HDL
HJD
BHE

Internal structure and parts list

● HLC-08CS (Standard)

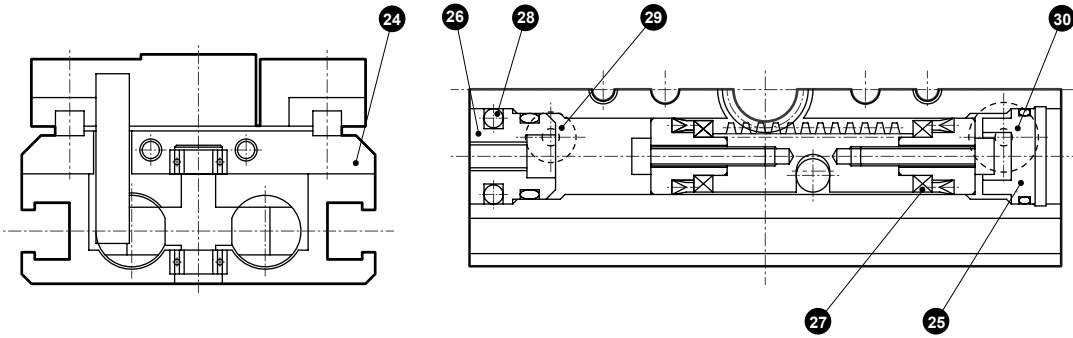

● HLC-12CS to 30CS (Standard)

● HLC-12CS to 30CS-L1

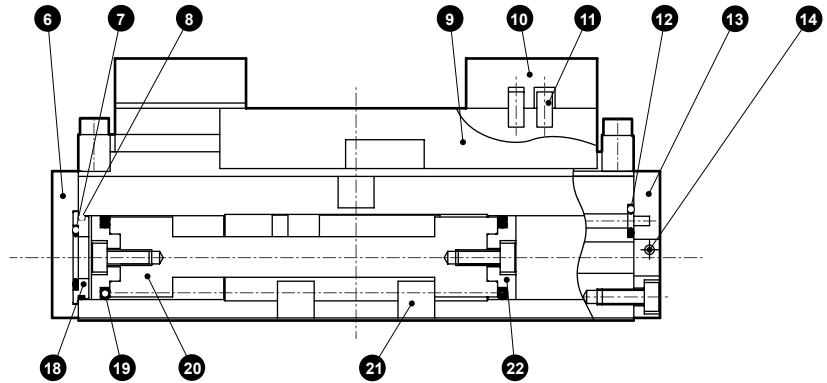
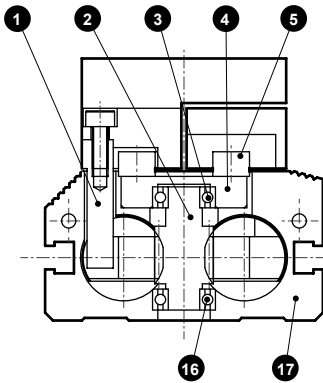
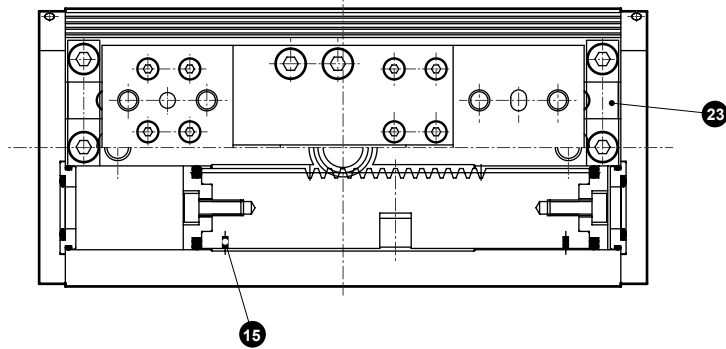

Cannot be disassembled

Parts list

No.	Part name	Material	Remarks	No.	Part name	Material	Remarks
1	Rack joint	Carbon steel		16	Single row deep groove ball bearing		20CS only
2	Pinion	Stainless steel		17	Body	Aluminum alloy	
3	Single row deep groove ball bearing			18	Cylinder guard 1	Aluminum alloy	
4	Bearing holder *1	Aluminum alloy		19	Piston seal	Nitrile rubber	
5	LM guide			20	Rack	Stainless steel	
6	Side plate 2 *1	Aluminum alloy		21	Key *2	16CS to 25CS are carbon steel and 30CS is stainless steel	
7	Cylinder sealant 1	Nitrile rubber		22	Piston	Acetal resin	
8	Cylinder sealant 2	Nitrile rubber		23	Stiffening plate	Stainless steel	16CS, 20CS only
9	LM plate *2	Aluminum alloy		24	Linear guide mounting base	Aluminum alloy	
10	Finger	Aluminum alloy		25	Cylinder guard 2	Acetal resin	
11	Positioning pin			26	Cylinder guard 3	Aluminum alloy	
12	Gasket 1	Nitrile rubber		27	Magnet		
13	Side plate 1 *1	Aluminum alloy		28	Rotation-stop pin	Stainless steel	
14	Steel ball	Stainless steel		29	Gasket 2	Nitrile rubber	
15	Semicircle magnet			30	Gasket 3	Nitrile rubber	

*1: Not supplied with 08CS.

*2: Not supplied with 08CS and 12CS.

- LCM
- LCR
- LCG
- LCW
- LX
- STM
- STG
- STS/STL
- STR2
- UCA2
- ULK*
- JSK/M2
- JSG
- JSC3/USC4
- USSD
- UFCD
- USC
- UB
- JSB3
- LMB
- LML
- HCM
- HCA
- LBC
- CAC4
- UCAC2
- CAC-N
- UCAC-N
- RCS2
- RCC2
- PCC
- SHC
- MCP
- GLC
- MFC
- BBS
- RRC
- GRC
- RV3*
- NHS
- HRL
- LN
- Hand**
- Chuk
- MecHnd/Chuk
- ShkAbs
- FJ
- FK
- SpdContr
- Ending
- LSH-HP
- LSH
- FH100
- BSA2
- BHA/BHG
- LHA
- LHAG
- HAP
- HKP
- HCP
- HGP
- HLF2
- HLA/HLB
- HLAG/HLBG
- HLC**
- HLD
- HMF
- HMF-G
- HMFB
- HFP
- FH500
- HBL
- HJL
- HMD
- HDL
- HJD
- BHE

Gripping power performance data

- Gripping power represents the thrust (per one finger) in the arrow direction shown in the figure.
- The gripping power with finger length L of hand and a supply pressure of 0.3, 0.5 and 0.7 MPa is shown.
- Both open direction (◁▷) and closed direction (◼◻) (shown with continuous line)

(Note) When making a selection, read the precautions for design and selection on page 1764.

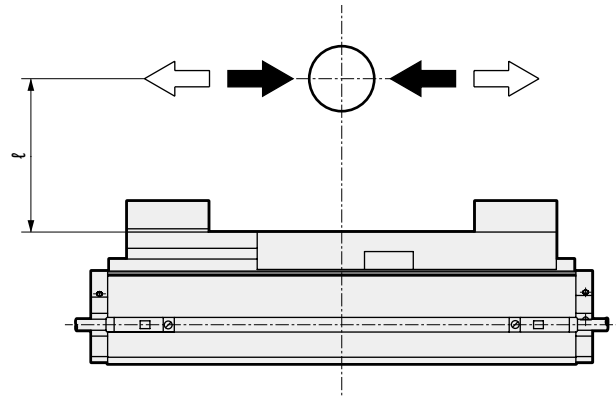

● HLC-08CS

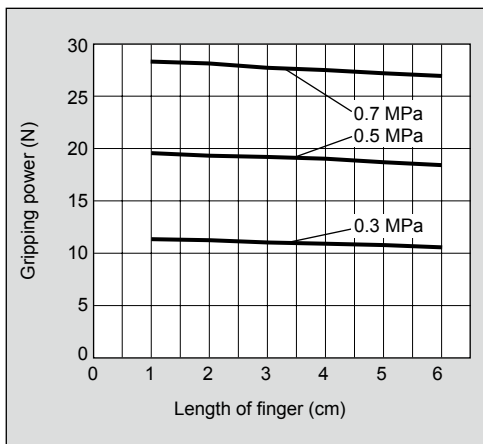

● HLC-12CS

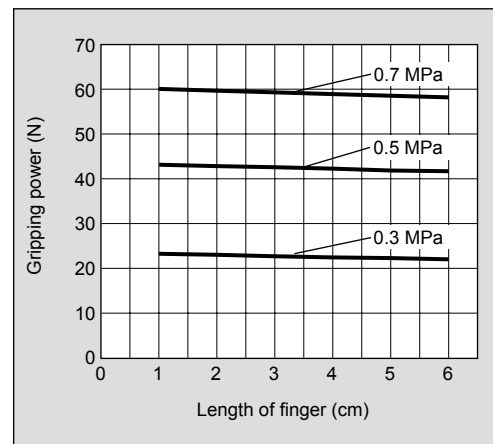

● HLC-16CS

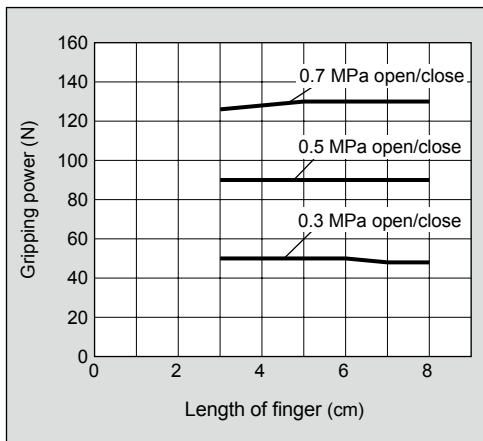

● HLC-20CS

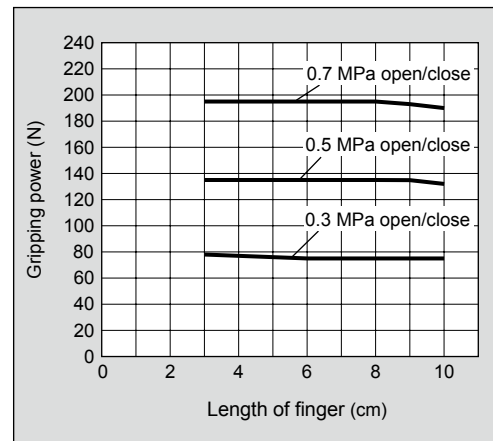

● HLC-25CS

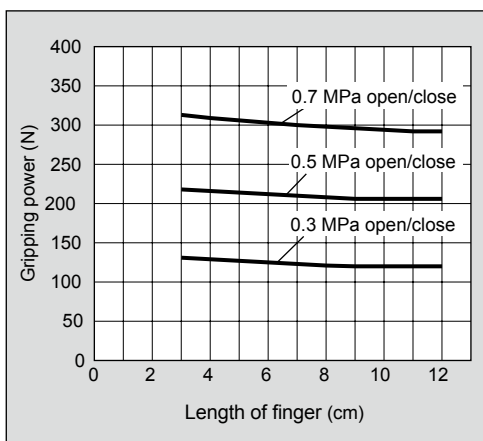

● HLC-30CS

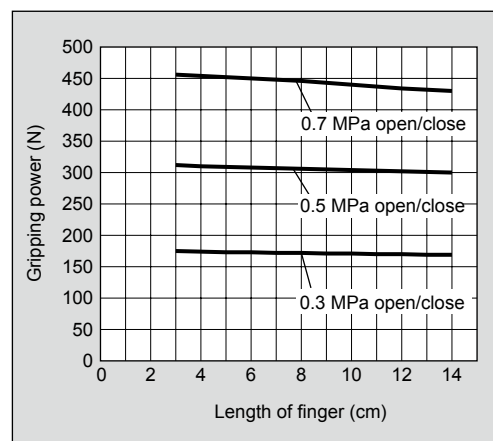

LCM
LCR
LCG
LCW
LCX
STM
STG
STS/STL
STR2
UCA2
ULK*
JSK/M2
JSG
JSC3/JSC4
USSD
UFCD
USC
UB
JSB3
LMB
LML
HCM
HCA
LBC
CAC4
UCAC2
CAC-N
UCAC-N
RCS2
RCC2
PCC
SHC
MCP
GLC
MFC
BBS
RRC
GRC
RV3*
NHS
HRL
LN
Hand
Chuk
MechHnd/Chuk
ShkAbs
FJ
FK
SpdContr
Ending
LSH-HP
LSH
FH100
BSA2
BHA/BHG
LHA
LHAG
HAP
HKP
HCP
HGP
HLF2
HLAG/HLBG
HLAG/HLBG
HLC
HLD
HMF
HMF-G
HMFB
HFP
FH500
HBL
HJL
HMD
HDL
HJD
BHE

Dimensions



● HLC-08CS Standard

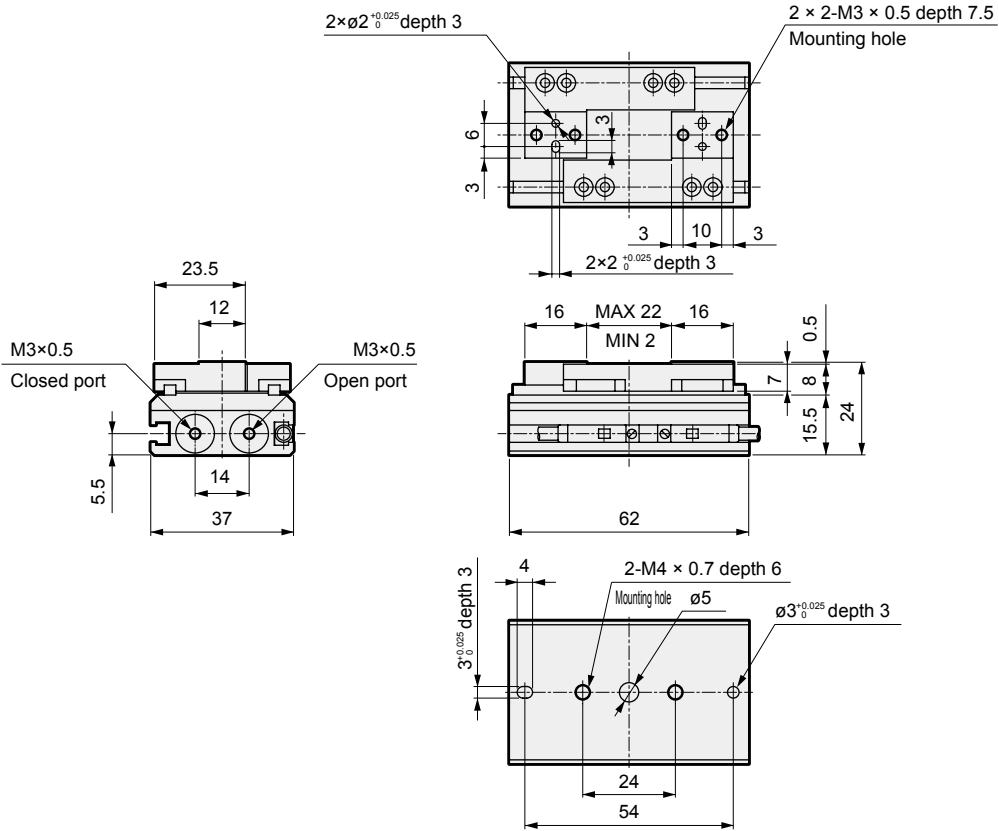

● HLC-12CS Standard/L1

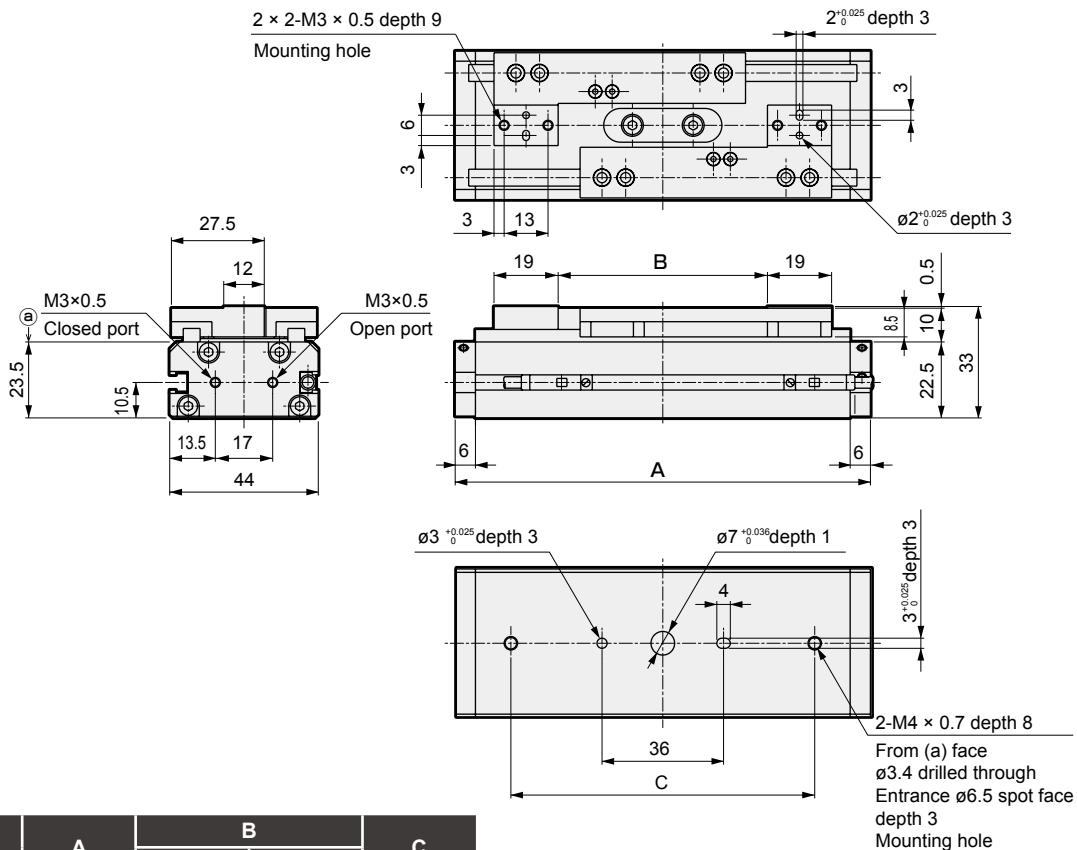

Code	A	B		C
		MAX	MIN	
Standard	78	32	2	54
L1	123	62	2	90

- LCM
- LCR
- LCG
- LCW
- LCX
- STM
- STG
- STS/STL
- STR2
- UCA2
- ULK*
- JSK/M2
- JSG
- JSC3/JSC4
- USSD
- UFCD
- USC
- UB
- JSB3
- LMB
- LML
- HCM
- HCA
- LBC
- CAC4
- UCAC2
- CAC-N
- UCAC-N
- RCS2
- RCC2
- PCC
- SHC
- MCP
- GLC
- MFC
- BBS
- RRC
- GRC
- RV3*
- NHS
- HRL
- LN
- Hand**
- Chuk
- MecHnd/Chuk
- ShkAbs
- FJ
- FK
- SpdContr
- Ending
- LSH-HP
- LSH
- FH100
- BSA2
- BHA/BHG
- LHA
- LHAG
- HAP
- HKP
- HCP
- HGP
- HLF2
- HLA/HLB
- HLAG/HLBG
- HLC**
- HLD
- HMF
- HMF-G
- HMFB
- HFP
- FH500
- HBL
- HJL
- HMD
- HDL
- HJD
- BHE

Dimensions

● HLC-16CS Standard/L1

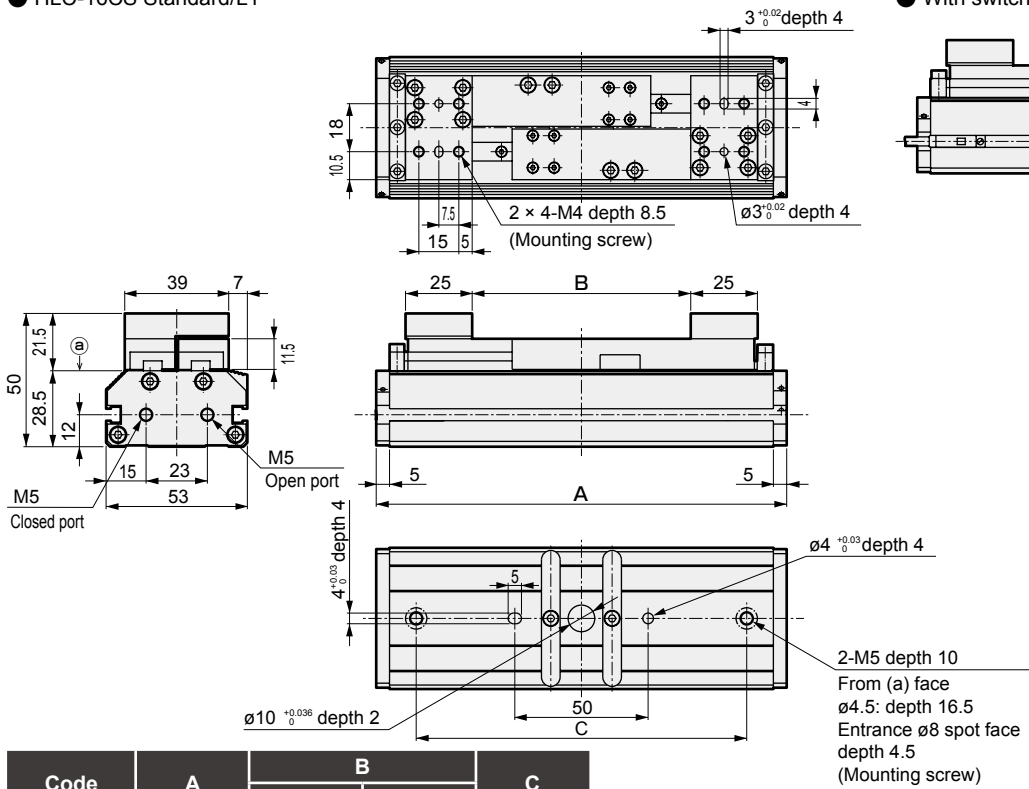

Code	A	B		C
		MAX	MIN	
Standard	116	42	2	86
L1	154	82	2	124

● HLC-20CS Standard/L1

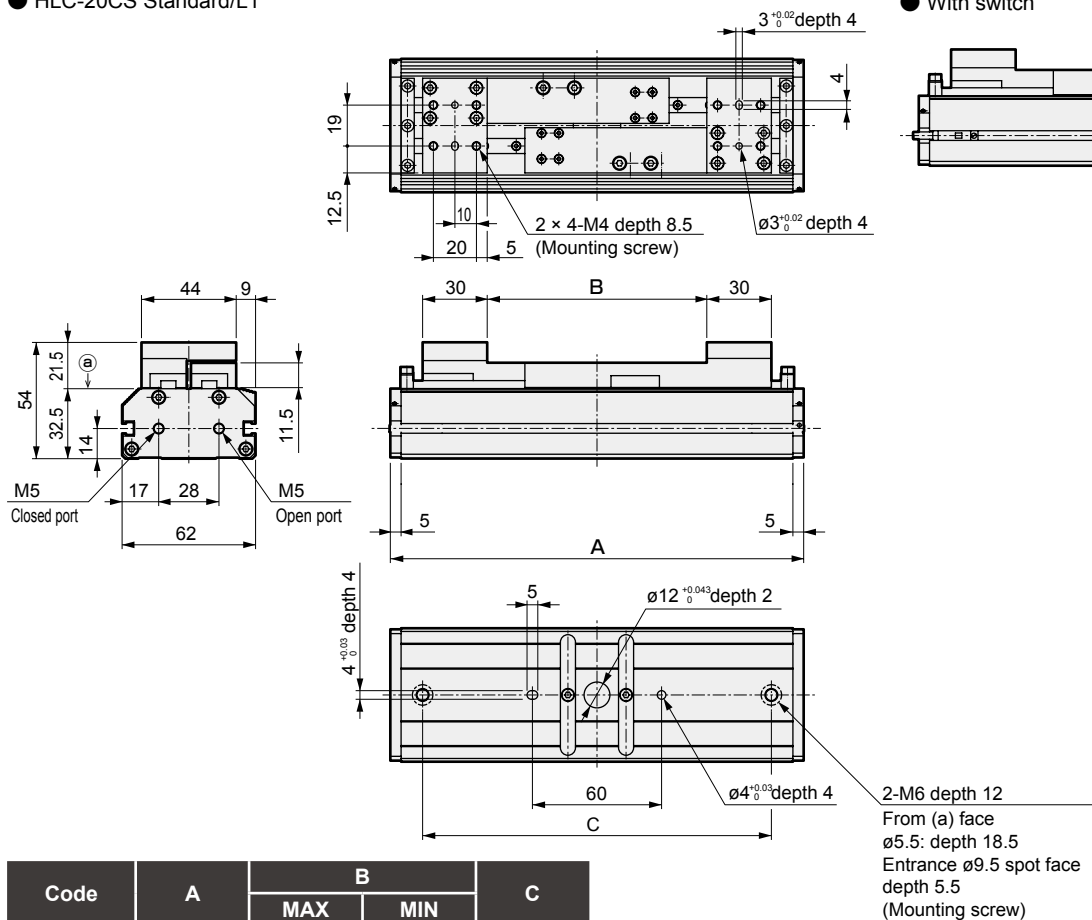

Code	A	B		C
		MAX	MIN	
Standard	132	52	2	102
L1	192	102	2	162

● With switch



● With switch



LCM
LCR
LCG
LCW
LCX
STM
STG
STS/STL
STR2
UCA2
ULK*
JSK/M2
JSG
JSC3/JSC4
USSD
UFCD
USC
UB
JSB3
LMB
LML
HCM
HCA
LBC
CAC4
UCAC2
CAC-N
UCAC-N
RCS2
RCC2
PCC
SHC
MCP
GLC
MFC
BBS
RRC
GRC
RV3*
NHS
HRL
LN
Hand
Chuk
MechHnd/Chuk
ShkAbs
FJ
FK
SpdContr
Ending
LSH-HP
LSH
FH100
BSA2
BHA/BHG
LHA
LHAG
HAP
HKP
HCP
HGP
HLF2
HLAG/HLBG
HLAG/HLBG
HLC
HLD
HMF
HMF-G
HMFB
HFP
FH500
HBL
HJL
HMD
HDL
HJD
BHE

Dimensions



● HLC-25CS Standard/L1

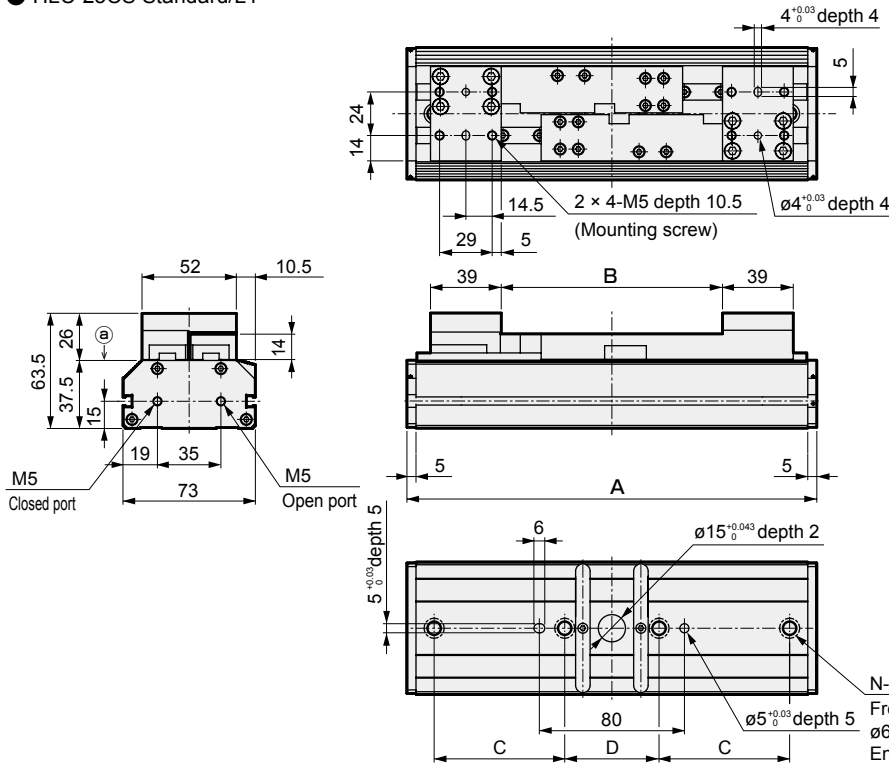

● With switch



Code	A	B		C	D	N
		MAX	MIN			
Standard	152	62	2	0	122	2
L1	226	122	2	72	52	4

● HLC-30CS Standard/L1

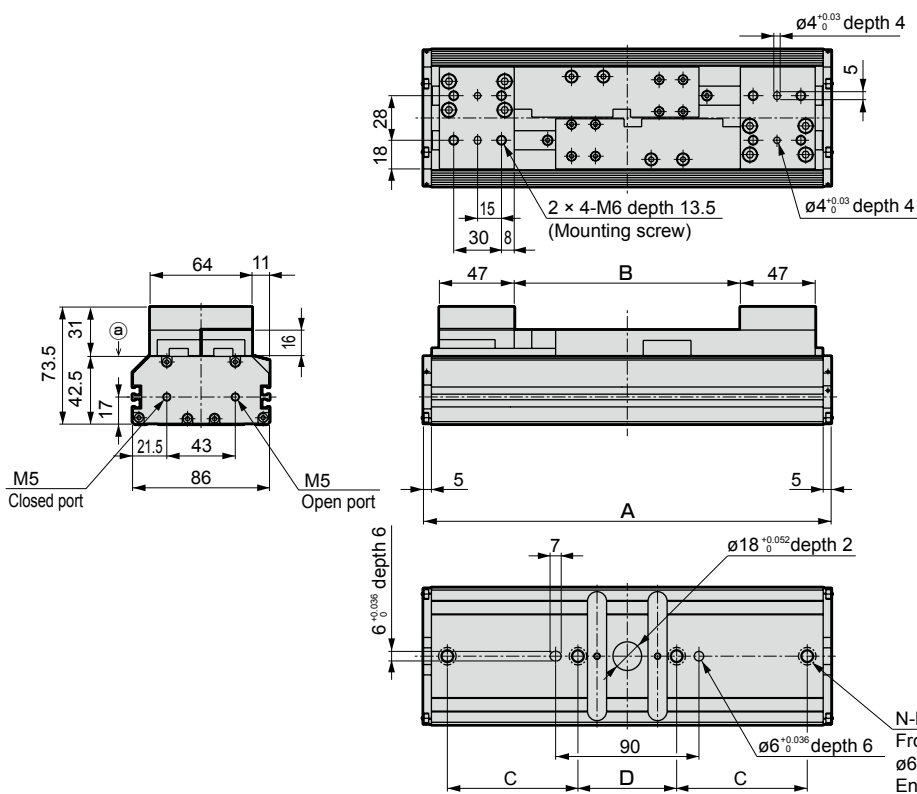

● With switch

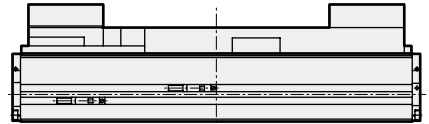

Code	A	B		C	D	N
		MAX	MIN			
Standard	174	72	2	0	144	2
L1	256	142	2	82	62	4

- LCM
- LCR
- LCG
- LCW
- L CX
- STM
- STG
- STS/STL
- STR2
- UCA2
- ULK*
- JSK/M2
- JSG
- JSC3/JSC4
- USSD
- UFCD
- USC
- UB
- JSB3
- LMB
- LML
- HCM
- HCA
- LBC
- CAC4
- UCAC2
- CAC-N
- UCAC-N
- RCS2
- RCC2
- PCC
- SHC
- MCP
- GLC
- MFC
- BBS
- RRC
- GRC
- RV3*
- NHS
- HRL
- LN
- Hand**
- Chuk
- MecHnd/Chuk
- ShkAbs
- FJ
- FK
- SpdContr
- Ending
- LSH-HP
- LSH
- FH100
- BSA2
- BHA/BHG
- LHA
- LHAG
- HAP
- HKP
- HCP
- HGP
- HLF2
- HLA/HLB
- HLAG/HLBG
- HLC**
- HLD
- HMF
- HMF-G
- HMFB
- HFP
- FH500
- HBL
- HJL
- HMD
- HDL
- HJD
- BHE