

180 degree open/close thin wide angle hand

HMD Series

● Open/close angle: -4° to 184°

Double acting



Specifications

Item	HMD			
	12CS	16CS	20CS	25CS
Size	12CS	16CS	20CS	25CS
Bore size mm	$\varnothing 12$	$\varnothing 16$	$\varnothing 20$	$\varnothing 25$
Actuation	Double acting			
Working fluid	Compressed air			
Max. working pressure MPa	0.7 (≈ 100 psi, 7 bar)			
Min. working pressure MPa	0.3 (≈ 44 psi, 3 bar)			
Ambient temperature $^{\circ}\text{C}$	5 (41°F) to 60 (140°F)			
Port size	M3		M5	
Open and close angle $^{\circ}$	-4 to 184			
Rod diameter mm	$\varnothing 6$		$\varnothing 8$	
Volumetric capacity (reciprocating) cm^3	2.3	5.8	8.7	19.4
Repeatability mm	± 0.2			
Weight kg	0.074	0.13	0.26	0.38
Lubrication	Not required (use turbine oil class 1 ISO VG32 if necessary for lubrication)			

Switch specifications

Item	Proximity 2-wire	Proximity 3-wire
	T2H/V	T3H/V
Applications	Dedicated for programmable controller	For programmable controller, relay
Output method	-	NPN output
Power supply voltage	-	10 to 28 VDC
Load voltage/current	10 to 30 VDC, 5 to 20 mA (*1)	30 VDC or less, 100 mA or less
Indicator lamp	LED (Lit when ON)	
Leakage current	1 mA or less	10 μA or less
Weight	1 m:18 g 3 m:49 g 5 m:80 g	

*1 : The above max. load current is 20 mA at 25°C .

The current is lower than 20 mA if the operating ambient temperature around the switch is higher than 25°C . (5 to 10 mA at 60°C)

*2 : Refer to Ending Page 1 for detailed switch specifications and dimensions.

- LCM
- LCR
- LCG
- LCW
- LCX
- STM
- STG
- STS/STL
- STR2
- UCA2
- ULK*
- JSK/M2
- JSG
- JSC3/JSC4
- USSD
- UFCD
- USC
- UB
- JSB3
- LMB
- LML
- HCM
- HCA
- LBC
- CAC4
- UCAC2
- CAC-N
- UCAC-N
- RCS2
- RCC2
- PCC
- SHC
- MCP
- GLC
- MFC
- BBS
- RRC
- GRC
- RV3*
- NHS
- HRL
- LN
- Hand
- Chuk
- MecHnd/Chuk
- ShkAbs
- FJ
- FK
- SpdContr
- Ending
- LSH-HP
- LSH
- FH100
- BSA2
- BHA/BHG
- LHA
- LHAG
- HAP
- HKP
- HCP
- HGP
- HLF2
- HLA/HLB
- HLAG/HLBG
- HLC
- HLD
- HMF
- HMF-G
- HMFB
- HFP
- FH500
- HBL
- HJL
- HMD**
- HDL
- HJD
- BHE

How to order

Without switch (built-in magnet for switch)

HMD - **16CS**

With switch (built-in magnet for switch)

HMD - **16CS** - **T2H** - **R**

Model No.

A Size

B Switch model No.

* indicates the lead wire length.

C Switch quantity

[Example of model No.]

HMD-16CS-T2H-R

Model : Thin wide angle hand

A Size : 16CS

B Switch model No. : Proximity T2H switch, lead wire 1 m

C Switch quantity : 1 on open side

Code	Description
A Size	
12CS	
16CS	
20CS	
25CS	
B Switch model No.	
Axial lead wire	Radial lead wire
T2H*	T2V*
T3H*	T3V*
* Lead wire length	
Blank	1 m (standard)
3	3 m (option)
5	5 m (option)
C Switch quantity	
R	1 on open side
H	1 on closed side
D	2

How to order switch

SW - **T2H***

Switch model No.
(Item **B** above)

Specifications for rechargeable battery (Catalog No. CC-1226A)

HMD - ... - **P4*** ● Design compatible with rechargeable battery manufacturing process.

* Contact CKD for details.

Internal structure and parts list

● HMD-12CS to 25CS

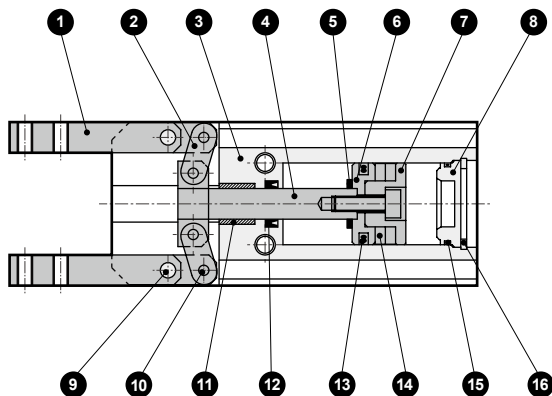

Cannot be disassembled

No.	Part name	Material	Remarks
1	Finger	Steel	
2	Link	Steel	
3	Body	Aluminum alloy	
4	Piston A	Stainless steel	
5	Cushion	Urethane rubber	
6	Piston B	Copper alloy	
7	Piston C	Copper alloy	
8	Cylinder guard	Acetal resin	
9	Fulcrum axis	Alloy steel	
10	Operation shaft	Alloy steel	
11	Bush	Sintering oil impregnated alloy	
12	Rod sealant	Nitrile rubber	
13	Piston seal	Nitrile rubber	
14	Magnet		
15	Cylinder sealant	Nitrile rubber	
16	Snap ring	Stainless steel	

- LCM
- LCR
- LCG
- LCW
- LCX
- STM
- STG
- STS/STL
- STR2
- UCA2
- ULK*
- JSK/M2
- JSG
- JSC3/JSC4
- USSD
- UFCD
- USC
- UB
- JSB3
- LMB
- LML
- HCM
- HCA
- LBC
- CAC4
- UCAC2
- CAC-N
- UCAC-N
- RCS2
- RCC2
- PCC
- SHC
- MCP
- GLC
- MFC
- BBS
- RRC
- GRC
- RV3*
- NHS
- HRL
- LN
- Hand**
- Chuk
- MechHnd/Chuk
- ShkAbs
- FJ
- FK
- SpdContr
- Ending
- LSH-HP
- LSH
- FH100
- BSA2
- BHA/BHG
- LHA
- LHAG
- HAP
- HKP
- HCP
- HGP
- HLF2
- HLA/HLB
- HLA/HLBG
- HLC
- HLD
- HMF
- HMF-G
- HMFB
- HFP
- FH500
- HBL
- HJL
- HMD**
- HDL
- HJD
- BHE

Gripping power performance data

- Gripping power represents the thrust (per one finger) in the arrow direction shown in the figure.
- The gripping power with finger length L of hand and a supply pressure of 0.3, 0.5 and 0.7 MPa is shown.

• Closed direction (➡) (shown with continuous line)

(Note) When making a selection, read the precautions for design and selection on page 1764.

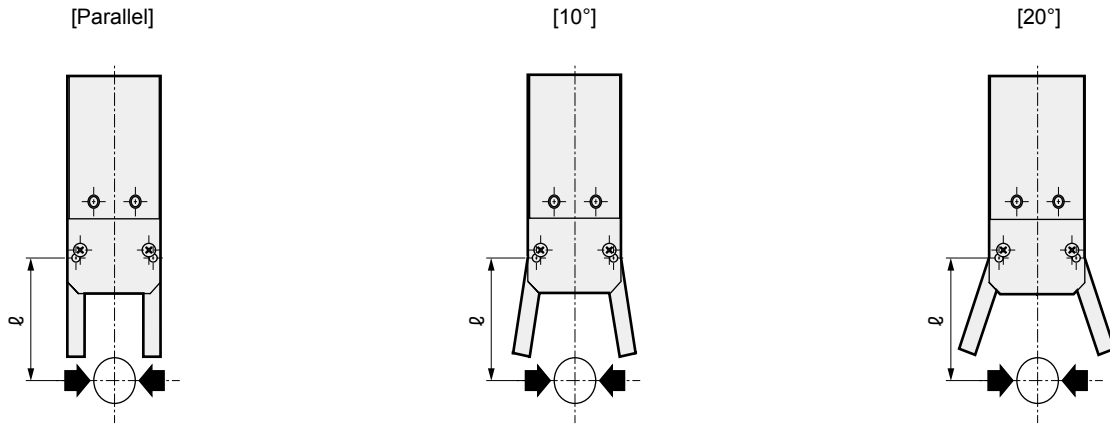

● HMD-12CS

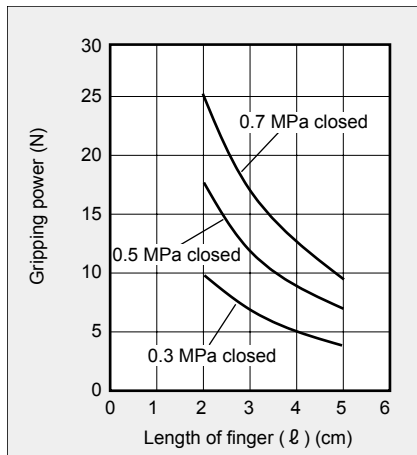

● HMD-12CS

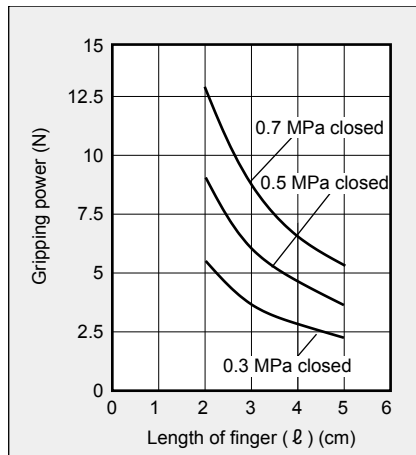

● HMD-12CS

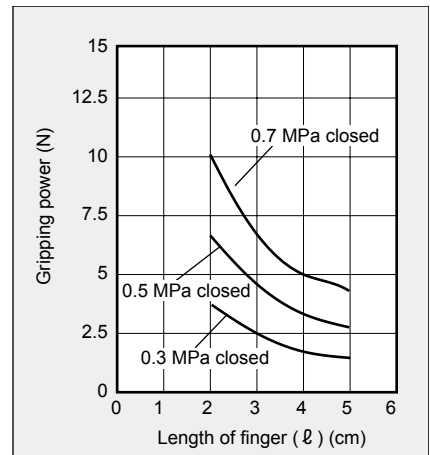

● HMD-16CS

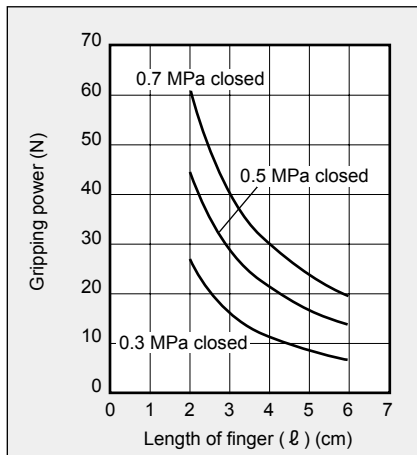

● HMD-16CS

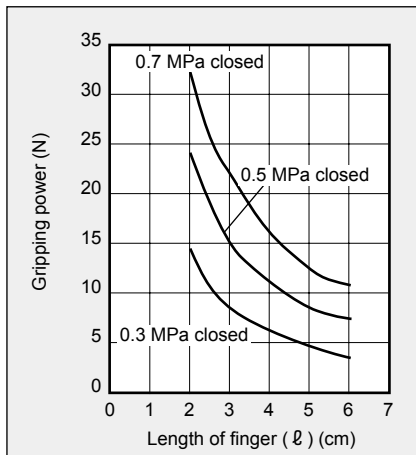

● HMD-16CS

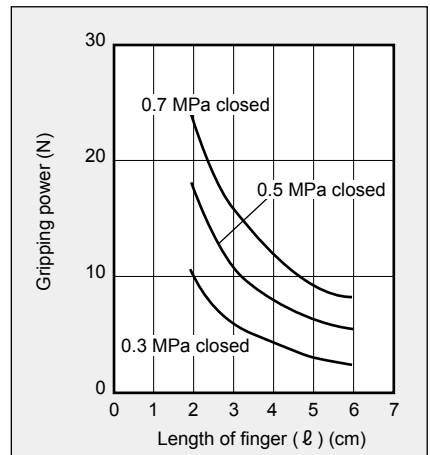

Gripping power performance data

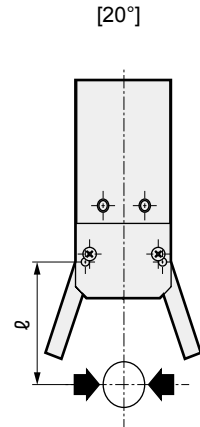
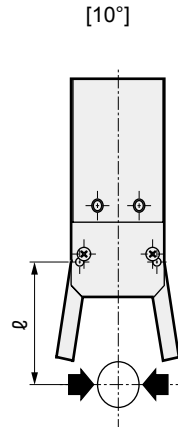
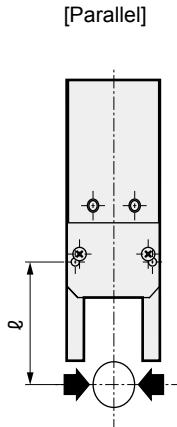

● HMD-20CS

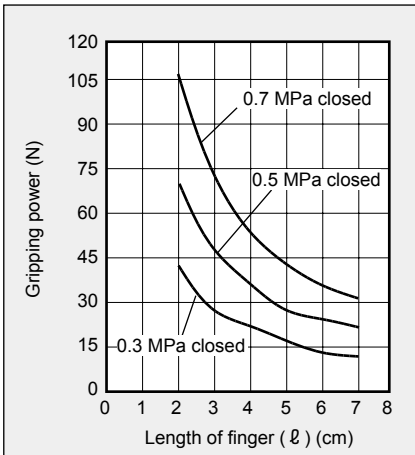

● HMD-20CS

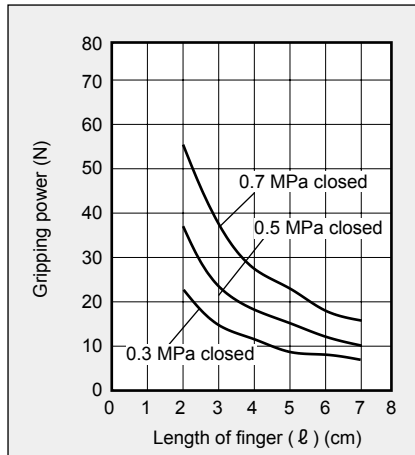

● HMD-20CS

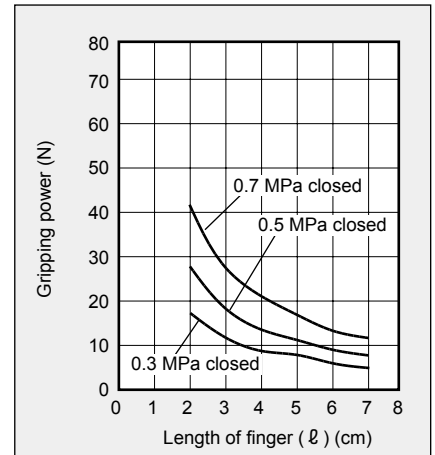

● HMD-25CS

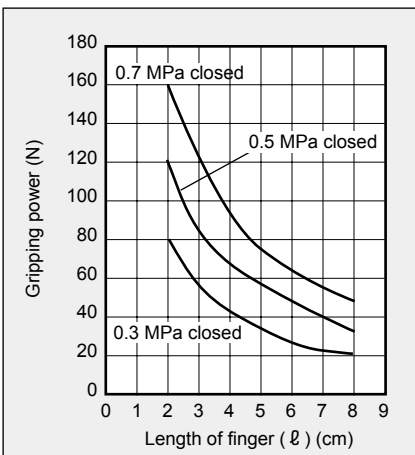

● HMD-25CS

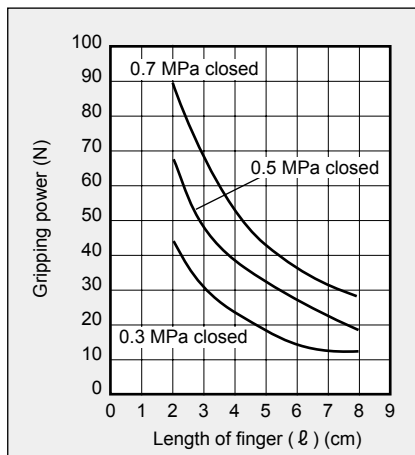

● HMD-25CS

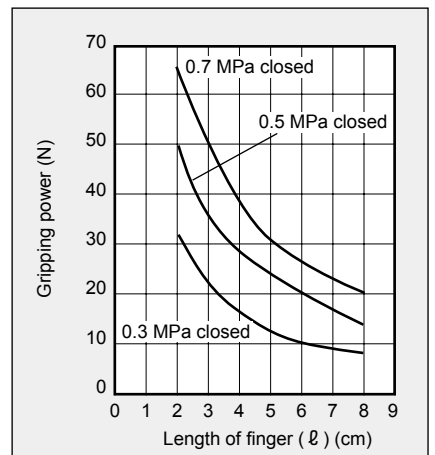

LCM
LCR
LCG
LCW
LCX
STM
STG
STS/STL
STR2
UCA2
ULK*
JSK/M2
JSG
JSC3/JSC4
USSD
UFCD
USC
UB
JSB3
LMB
LML
HCM
HCA
LBC
CAC4
UCAC2
CAC-N
UCAC-N
RCS2
RCC2
PCC
SHC
MCP
GLC
MFC
BBS
RRC
GRC
RV3*
NHS
HRL
LN
Hand
Chuk
MechHnd/Chuk
ShkAbs
FJ
FK
SpdContr
Ending

LSH-HP
LSH
FH100
BSA2
BHA/BHG
LHA
LHAG
HAP
HKP
HCP
HGP
HLF2
HLA/HLB
HLA/HLBG
HLC
HLD
HMF
HMF-G
HMFB
HFP
FH500
HBL
HJL
HMD
HDL
HJD
BHE



LCM
LCR
LCG
LCW
LCX
STM
STG
STS/STL
STR2
UCA2
ULK*
JSK/M2
JSG
JSC3/JSC4
USSD
UFCD
USC
UB
JSB3
LMB
LML
HCM
HCA
LBC
CAC4
UCAC2
CAC-N
UCAC-N
RCS2
RCC2
PCC
SHC
MCP
GLC
MFC
BBS
RRC
GRC
RV3*
NHS
HRL
LN
Hand
Chuk
MecHnd/Chuk
ShkAbs
FJ
FK
SpdContr
Ending
LSH-HP
LSH
FH100
BSA2
BHA/BHG
LHA
LHAG
HAP
HKP
HCP
HGP
HLF2
HLA/HLB
HLAG/HLBG
HLC
HLD
HMF
HMF-G
HMFB
HFP
FH500
HBL
HJL
HMD
HDL
HJD
BHE

● HMD-12CS

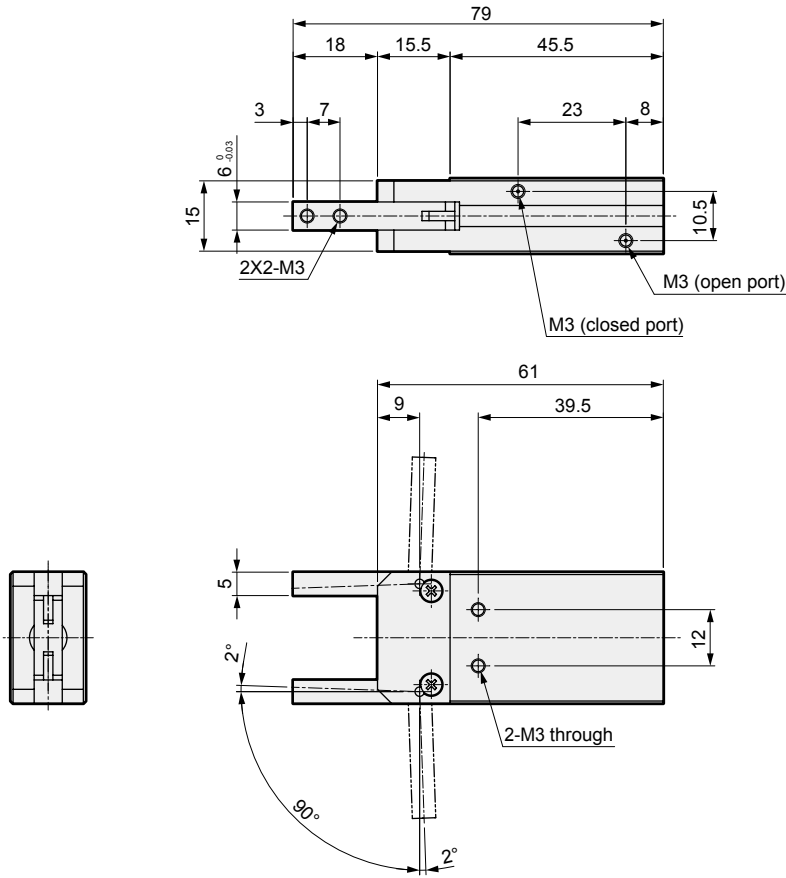

● With switch

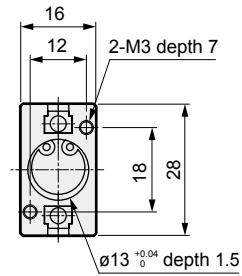
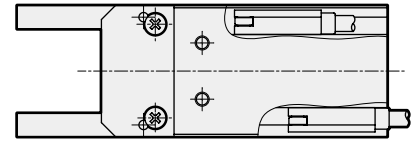

● HMD-16CS

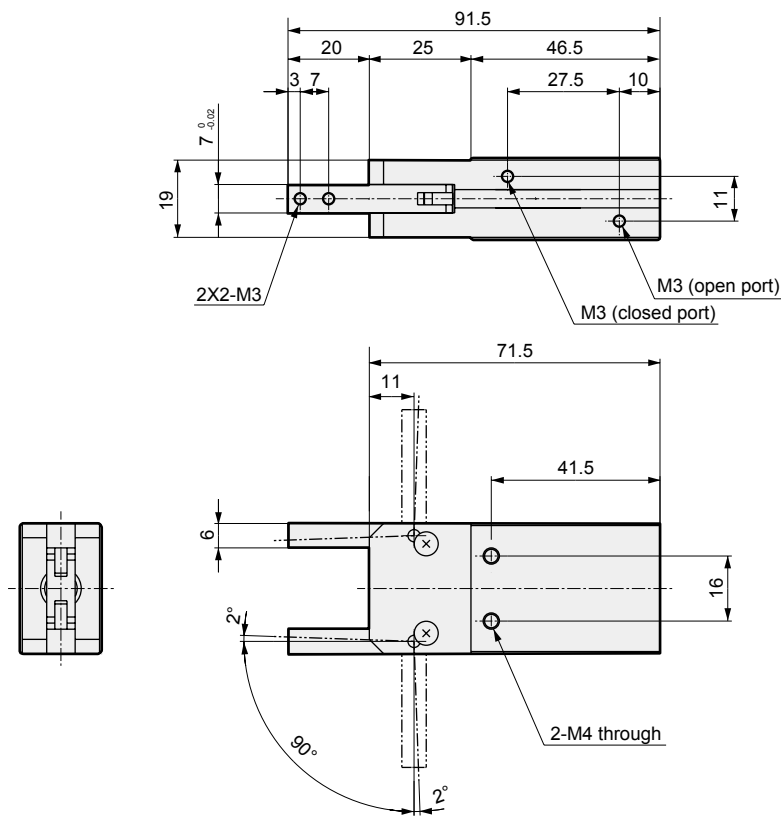

● With switch

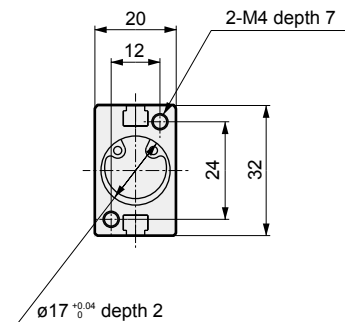
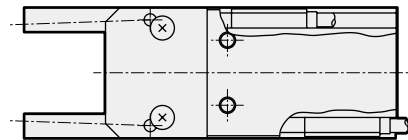

Dimensions

● HMD-20CS

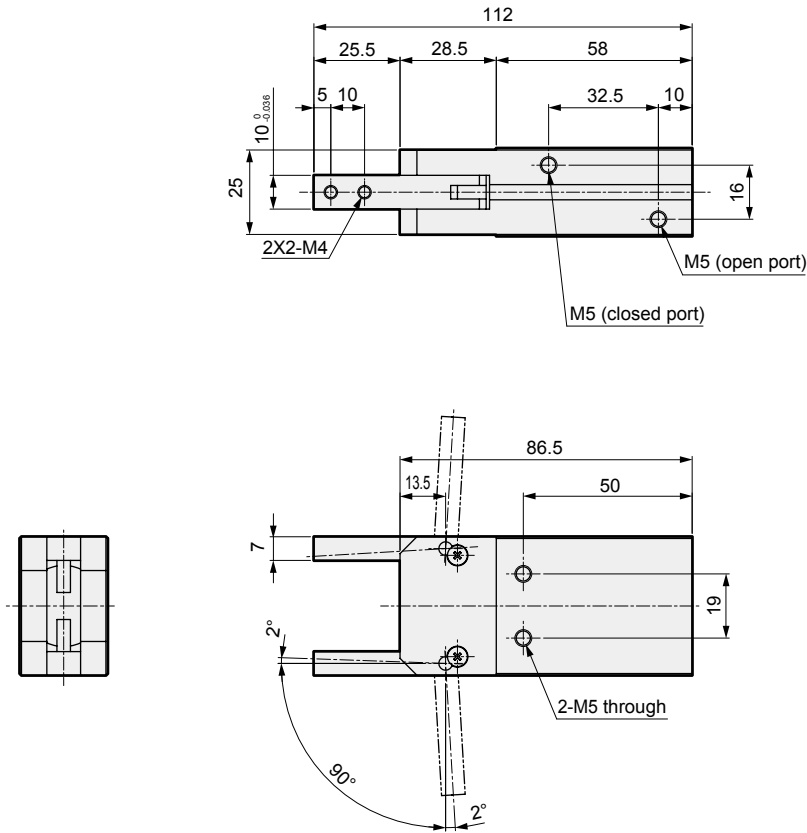

● With switch

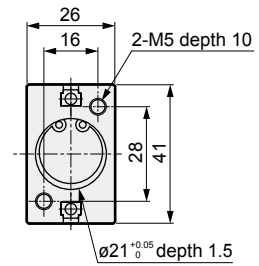
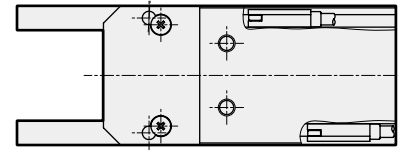

● HMD-25CS

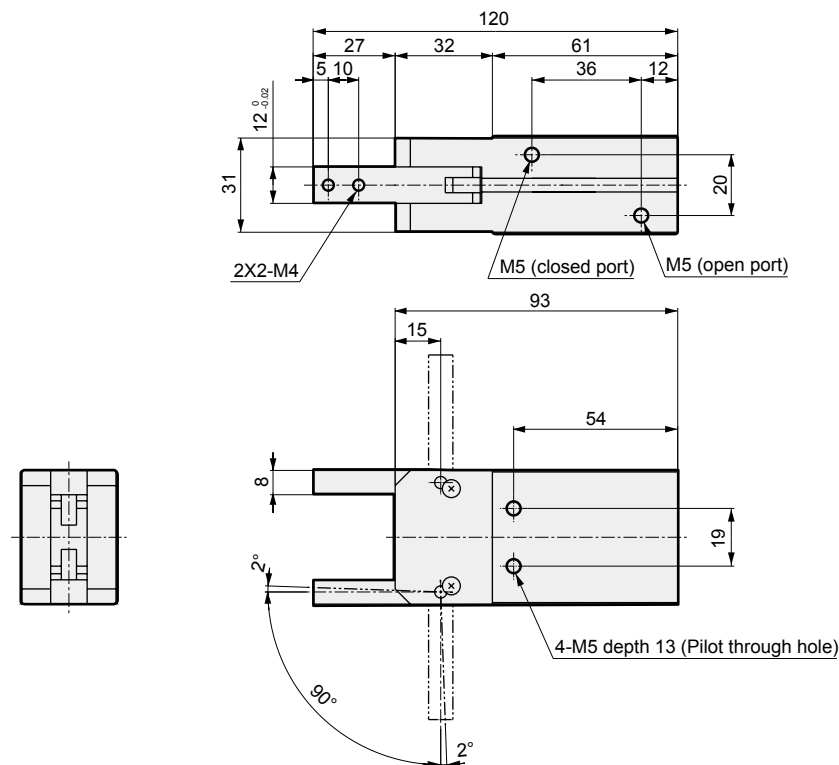

● With switch

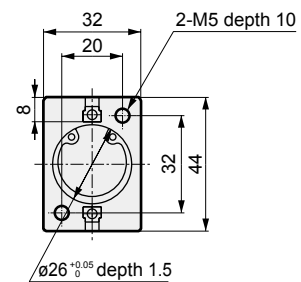
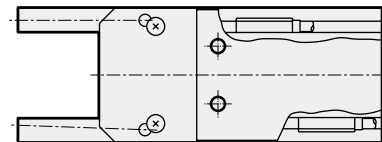

LCM
LCR
LCG
LCW
LCX
STM
STG
STS/STL
STR2
UCA2
ULK*
JSK/M2
JSG
JSC3/JSC4
USSD
UFCD
USC
UB
JSB3
LMB
LML
HCM
HCA
LBC
CAC4
UCAC2
CAC-N
UCAC-N
RCS2
RCC2
PCC
SHC
MCP
GLC
MFC
BBS
RRC
GRC
RV3*
NHS
HRL
LN
Hand
Chuk
MechHnd/Chuk
ShkAbs
FJ
FK
SpdContr
Ending
LSH-HP
LSH
FH100
BSA2
BHA/BHG
LHA
LHAG
HAP
HKP
HCP
HGP
HLF2
HLA/HLB
HLAG/HLBG
HLC
HLD
HMF
HMF-G
HMFB
HFP
FH500
HBL
HJL
HMD
HDL
HJD
BHE