

LCM
 LCR
 LCG
 LCW
 LCX
 STM
 STG
 STS/STL
 STR2
 UCA2
 ULK*
 JSK/M2
 JSG
 JSC3/JSC4
 USSD
 UFCD
 USC
 UB
 JSB3
 LMB
 LML
 HCM
 HCA
 LBC
 CAC4
 UCAC2
 CAC-N
 UCAC-N
 RCS2
 RCC2
 PCC
 SHC
 MCP
 GLC
 MFC
 BBS
 RRC
 GRC
 RV3*
 NHS
 HRL
 LN
 Hand
Chuk
 MechHnd/Chuk
 ShkAbs
 FJ
 FK
 SpdContr
 Ending
 CKL2
 CKLG2
 CKL2-HC
 CKH2
 CKLB2
 CKG
 CK
 CKA
CKS
 CKS-F
 CKF
 CKJ
 CHC

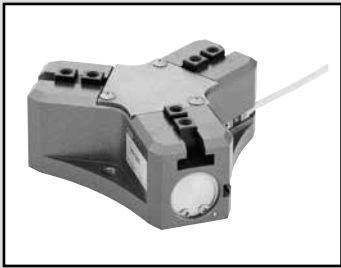

Thin chuck
CKS Series

● Operating stroke length: 10, 12, 16, 20, 28, 32mm
 Double acting



Specifications

Item	CKS						
	08CS	12CS	16CS	20CS	25CS	32CS	
Size							
Actuation	Double acting						
Working fluid	Compressed air						
Max. working pressure MPa	0.7 (≈100 psi, 7 bar)						
Min. working pressure MPa	0.2 (≈29 psi, 2 bar)						
Ambient temperature °C	5 (41°F) to 60 (140°F)						
Port size	M5						
Operating stroke length mm	10	12	16	20	28	32	
Bore size	Open direction	ø6×3	ø10×3	ø12×3	ø16×3	ø20×3	ø25×3
	Closed direction	ø8×3	ø12×3	ø16×3	ø20×3	ø25×3	ø32×3
Volumetric capacity (reciprocating) cm ³	1.2	3.5	7.6	15.5	33.8	62.2	
Repeatability mm	±0.01						
Weight kg	0.16	0.26	0.40	0.63	1.14	1.8	
Lubrication	Not required (use turbine oil class 1 ISO VG32 if necessary for lubrication)						

Switch specifications

Item	Proximity 2-wire	Proximity 3-wire
	T2H/V	T3H/V
Applications	Dedicated for programmable controller	For programmable controller, relay
Output method	-	NPN output
Power supply voltage	-	10 to 28 VDC
Load voltage/current	10 to 30 VDC, 5 to 20 mA (*1)	30 VDC or less, 100 mA or less
Indicator lamp	LED (Lit when ON)	
Leakage current	1 mA or less	10 µA or less
Weight	1 m:18 g 3 m:49 g 5 m:80 g	

*1 : The above max. load current is 20 mA at 25°C.

The current is lower than 20 mA if the operating ambient temperature around the switch is higher than 25°C. (5 to 10 mA at 60°C)

*2 : Refer to Ending Page 1 for detailed switch specifications and dimensions.

How to order

Without switch (built-in magnet for switch)

CKS - **16CS** - **Y1**

With switch (built-in magnet for switch)

CKS - **16CS** - **Y1** - **T2H** - **R**

Model No.

A Size

B Option
*1

C Switch model No.

D Switch quantity

Code	Description					
A Size						
08CS						
12CS						
16CS						
20CS						
25CS						
32CS						
B Option						
Blank	Standard (double acting)					
W	With spring					
Y1	With attachment Material: S50C					
Y2	With attachment Material: MC nylon					
C Switch model No.						
Axial lead wire	Radial lead wire	Contact	Voltage		Display	Lead wire
			AC	DC		
T2H*	T2V*	Proximity		●	1-color display	2-wire
T3H*	T3V*			●		3-wire
* Lead wire length						
Blank	1 m (standard)					
3	3 m (option)					
5	5 m (option)					
D Switch quantity						
R	1 on open side					
H	1 on closed side					
D	2					

⚠ Precautions for model No. selection

*1 : Refer to pages 1868 and 1869 for the dimensions and compatible model of the attachment.
When ordered as an option, three are attached at shipment.

[Example of model No.]

CKS-16CS-Y1-T2H-R

Thin chuck

- A** Size : 16CS
- B** Option : With attachment Material S50C
- C** Switch model No. : Proximity T2H switch, lead wire 1 m
- D** Switch quantity : 1 on open side

How to order switch

SW - **T2H***

Switch model No.
(Item **C** above)

LCM
LCR
LCG
LCW
LCX
STM
STG
STS/STL
STR2
UCA2
ULK*
JSK/M2
JSG
JSC3/JSC4
USSD
UFCD
USC
UB
JSB3
LMB
LML
HCM
HCA
LBC
CAC4
UCAC2
CAC-N
UCAC-N
RCS2
RCC2
PCC
SHC
MCP
GLC
MFC
BBS
RRC
GRC
RV3*
NHS
HRL
LN
Hand
Chuck
MechMtl/Chuck
ShkAbs
FJ
FK
SpdContr
Ending
CKL2
CKLG2
CKL2-HC
CKH2
CKLB2
CKG
CK
CKA
CKS
CKS-F
CKF
CKJ
CHC

Internal structure and parts list

● CKS standard

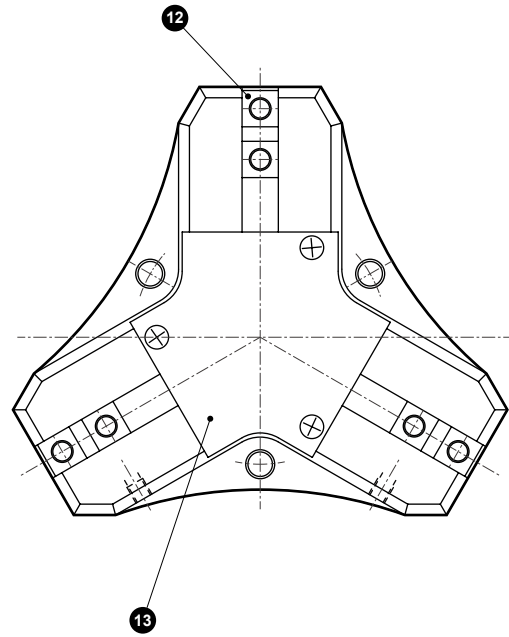
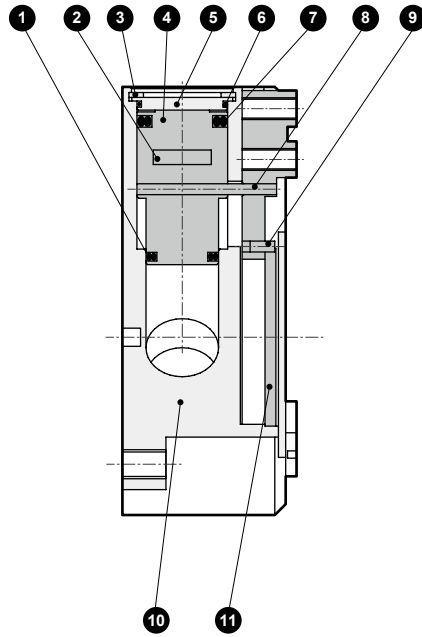

● W (with spring)

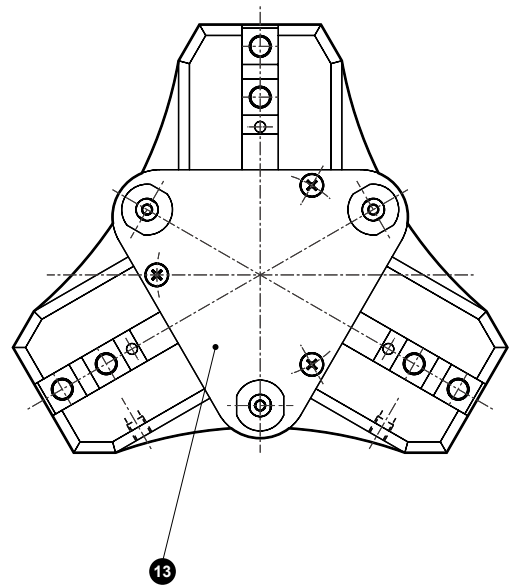
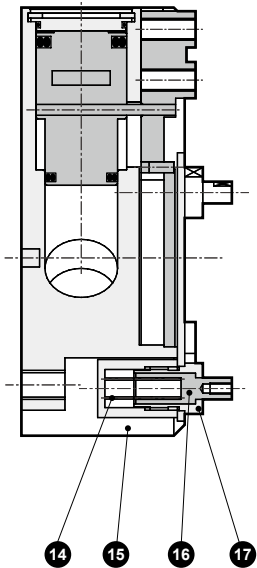

Cannot be disassembled

No.	Part name	Material	Remarks	No.	Part name	Material	Remarks
1	Piston seal B	Nitrile rubber		10	Body	Aluminum alloy	
2	Magnet			11	Link	Steel	
3	C type snap ring	Stainless steel		12	Finger	Steel	
4	Piston	Aluminum alloy		13	Center guard	Stainless steel	
5	Cylinder guard	Aluminum alloy		14	Spring	Steel	
6	Cylinder sealant	Nitrile rubber		15	Case	Stainless steel	
7	Piston seal A	Nitrile rubber		16	Pin	Stainless steel	
8	Operation shaft A	Alloy steel		17	Nut	Stainless steel	
9	Operation shaft B	Alloy steel					

Gripping power performance data

- Gripping power represents the thrust (per one finger) in the arrow direction shown in the figure.
- The gripping power in the opening/closing directions with jaw length L of hand with a supply pressure of 0.3, 0.5 and 0.7 MPa is shown.

- Open direction (←) ----- (shown with broken line)
- Closed direction (→) ————— (shown with continuous line)

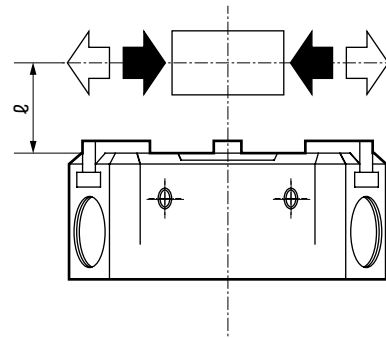

● CKS-08CS

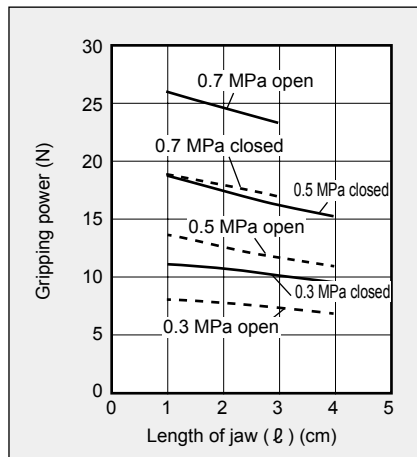

● CKS-12CS

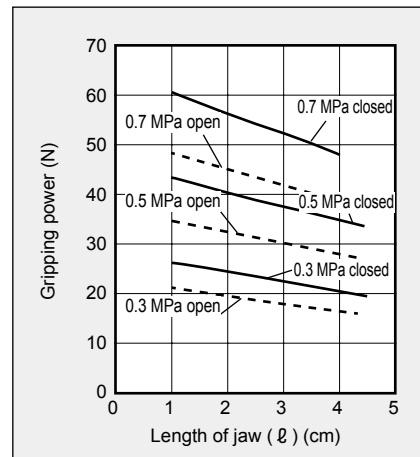

● CKS-16CS

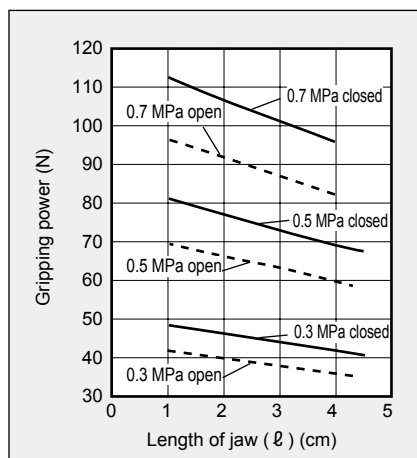

● CKS-20CS

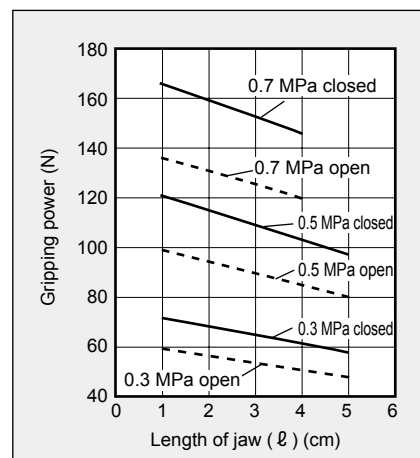

● CKS-25CS

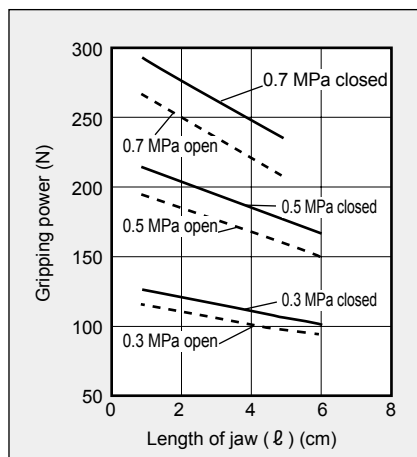

● CKS-32CS

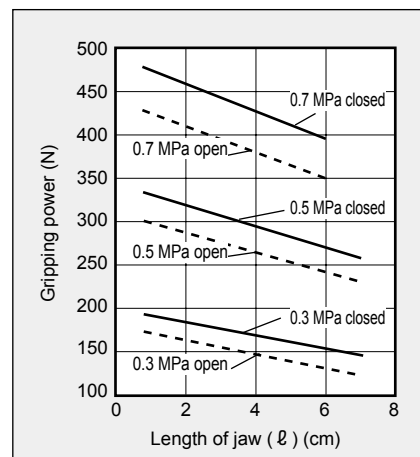

(Note) When making a selection, read the precautions for design and selection on page 1872.

LCM
LCR
LCG
LCW
LCX
STM
STG
STS/STL
STR2
UCA2
ULK*
JSK/M2
JSG
JSC3/JSC4
USSD
UFCD
USC
UB
JSB3
LMB
LML
HCM
HCA
LBC
CAC4
UCAC2
CAC-N
UCAC-N
RCS2
RCC2
PCC
SHC
MCP
GLC
MFC
BBS
RRC
GRC
RV3*
NHS
HRL
LN
Hand
Chuk
MechHnd/Chuk
ShkAbs
FJ
FK
SpdContr
Ending
CKL2
CKL2G
CKL2-HC
CKH2
CKLB2
CKG
CK
CKA
CKS
CKS-F
CKF
CKJ
CHC

Dimensions



● CKS-08CS standard

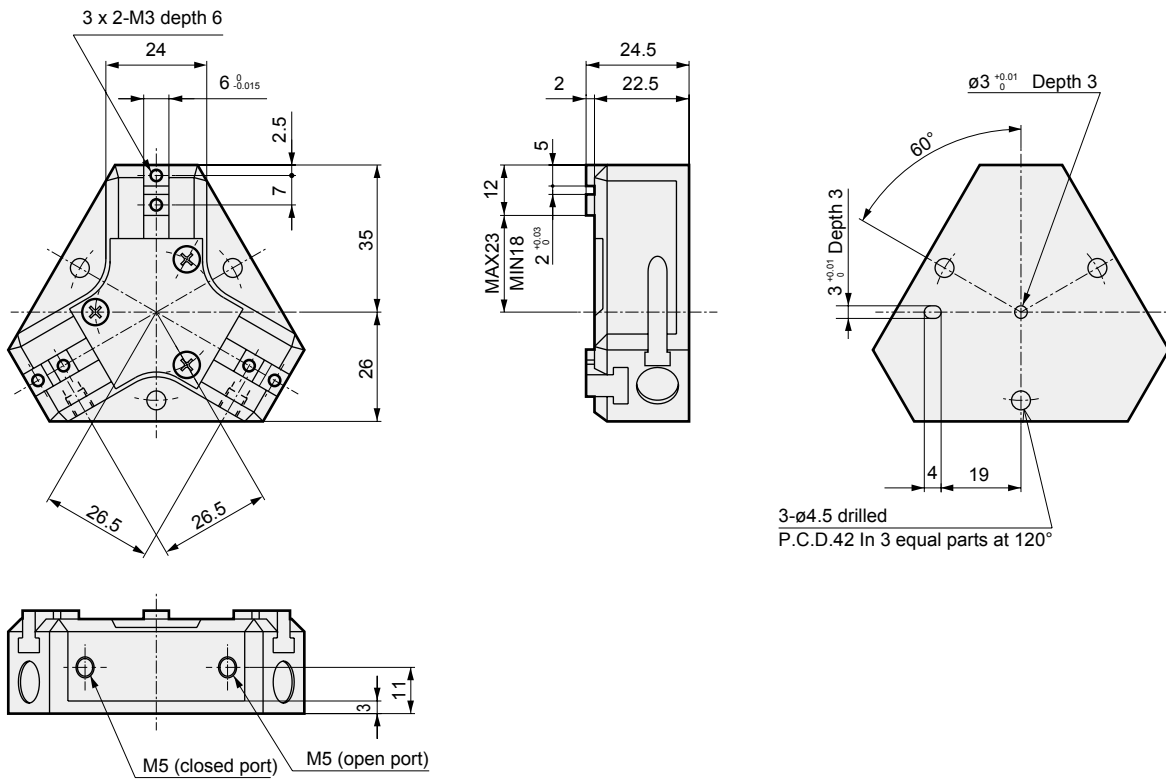

● CKS-08CS-W (with spring) (spring force (3 pcs.) 2.1 to 4.8N)

● With switch

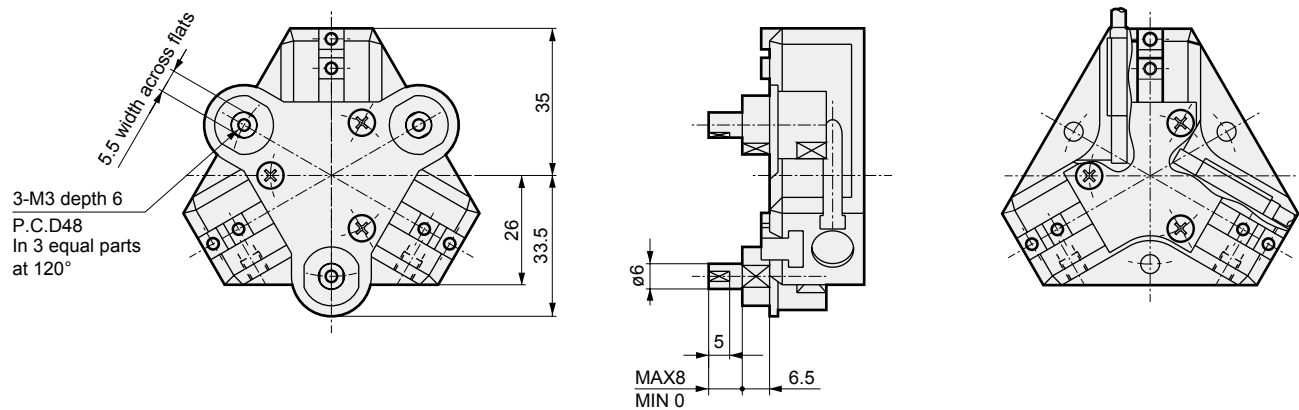

LCM
LCR
LCG
LCW
LCX
STM
STG
STS/STL
STR2
UCA2
ULK*
JSK/M2
JSG
JSC3/JSC4
USSD
UFCD
USC
UB
JSB3
LMB
LML
HCM
HCA
LBC
CAC4
UCAC2
CAC-N
UCAC-N
RCS2
RCC2
PCC
SHC
MCP
GLC
MFC
BBS
RRC
GRC
RV3*
NHS
HRL
LN
Hand
Chuk
MecHnd/Chuk
ShkAbs
FJ
FK
SpdContr
Ending
CKL2
CKLG2
CKL2-HC
CKH2
CKLB2
CKG
CK
CKA
CKS
CKS-F
CKF
CKJ
CHC

Dimensions

- CKS-12CS standard

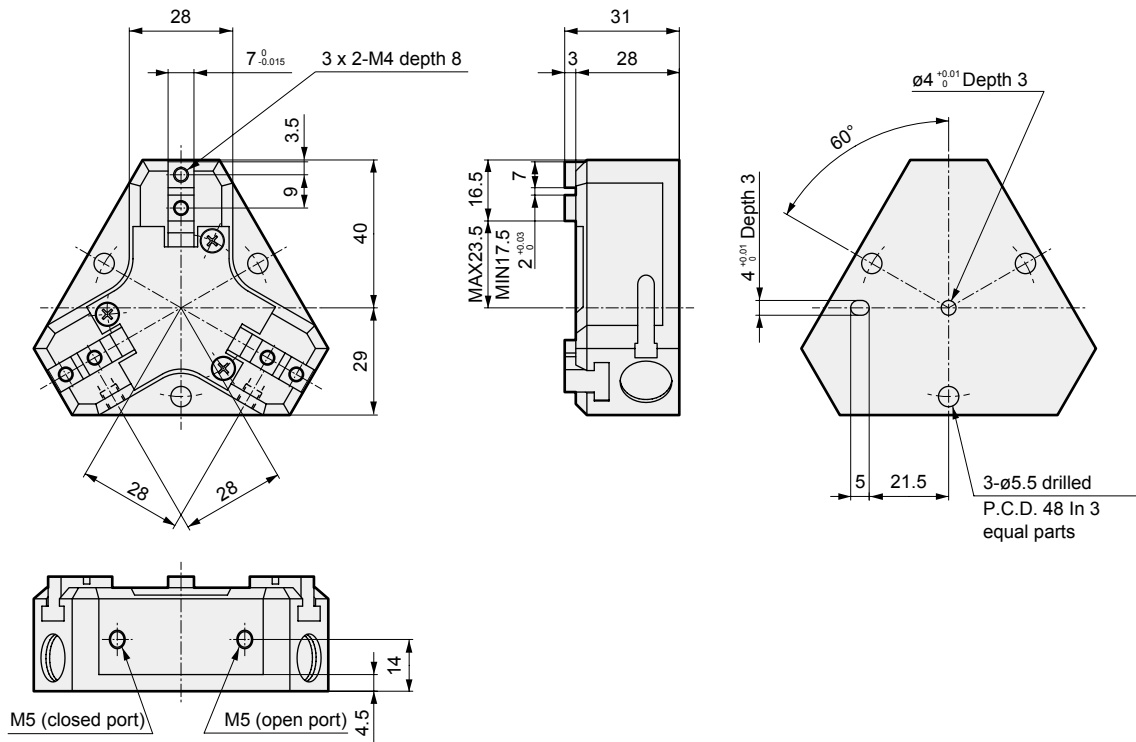

- CKS-12CS-W (with spring) (spring force (3 pcs.) 4.5 to 11.4N)

- With switch

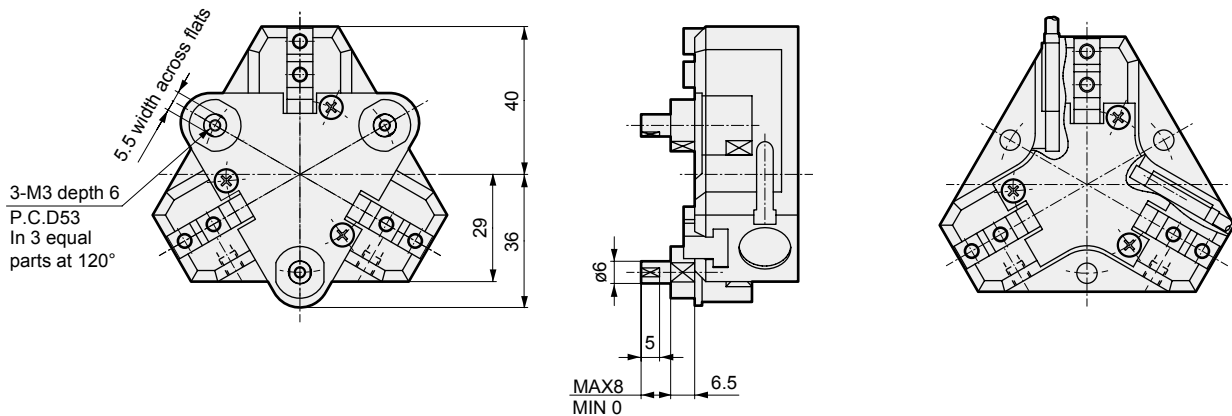

LCM
LCR
LCG
LCW
LCX
STM
STG
STS/STL
STR2
UCA2
ULK*
JSK/M2
JSG
JSC3/JSC4
USSD
UFCD
USC
UB
JSB3
LMB
LML
HCM
HCA
LBC
CAC4
UCAC2
CAC-N
UCAC-N
RCS2
RCC2
PCC
SHC
MCP
GLC
MFC
BBS
RRC
GRC
RV3*
NHS
HRL
LN
Hand
Chuk
MechMtlChuk
ShkAbs
FJ
FK
SpdContr
Ending
CKL2
CKLG2
CKL2-HC
CKH2
CKLB2
CKG
CK
CKA
CKS
CKS-F
CKF
CKJ
CHC

Dimensions



● CKS-16CS standard

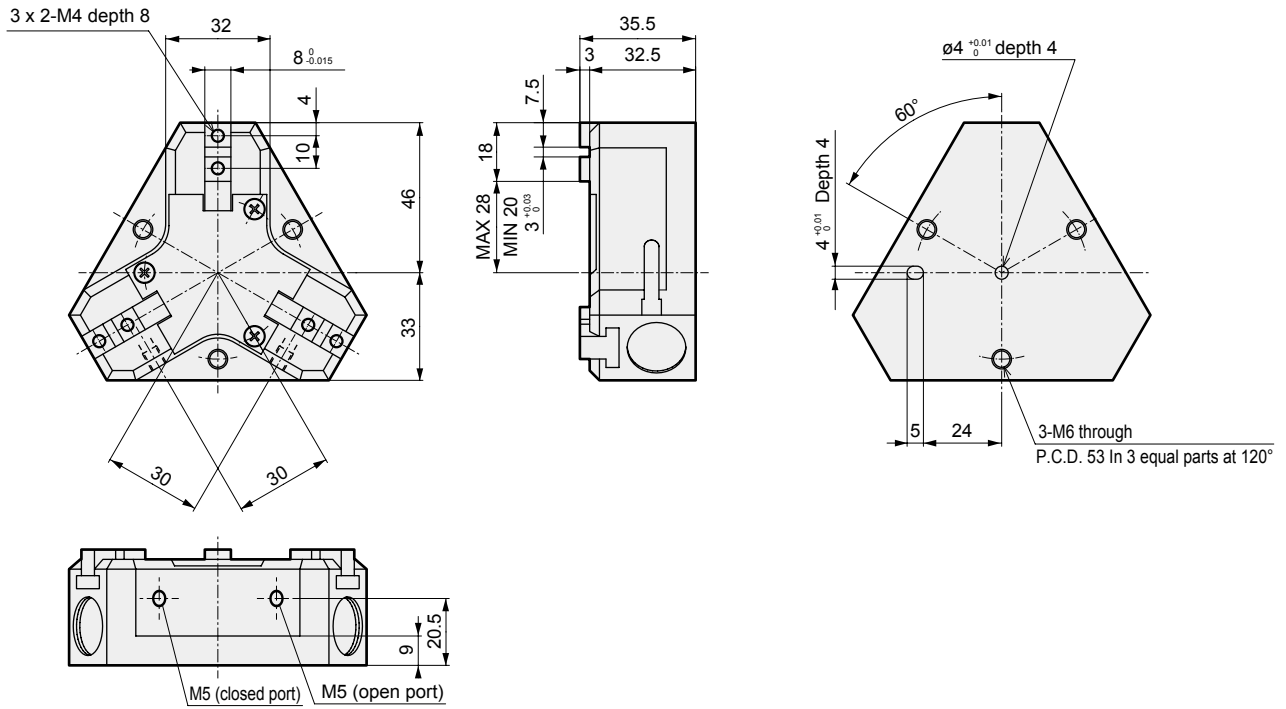

● CKS-16CS-W (with spring) (spring force (3 pcs.) 7.2 to 19N)

● With switch

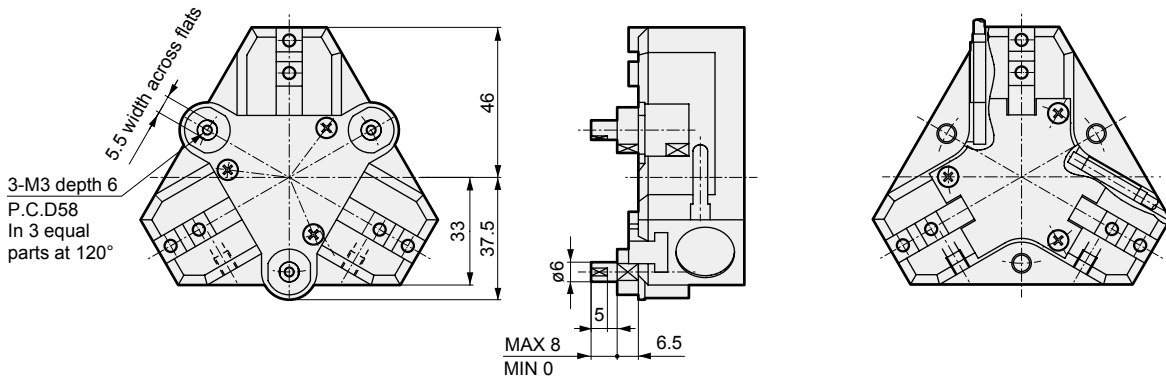

LCM
LCR
LCG
LCW
LCX
STM
STG
STS/STL
STR2
UCA2
ULK*
JSK/M2
JSG
JSC3/USC4
USSD
UFCD
USC
UB
JSB3
LMB
LML
HCM
HCA
LBC
CAC4
UCAC2
CAC-N
UCAC-N
RCS2
RCC2
PCC
SHC
MCP
GLC
MFC
BBS
RRC
GRC
RV3*
NHS
HRL
LN
Hand
Chuk
MecHnd/Chuk
ShkAbs
FJ
FK
SpdContr
Ending
CKL2
CKLG2
CKL2-HC
CKH2
CKLB2
CKG
CK
CKA
CKS
CKS-F
CKF
CKJ
CHC

Dimensions

● CKS-20CS standard

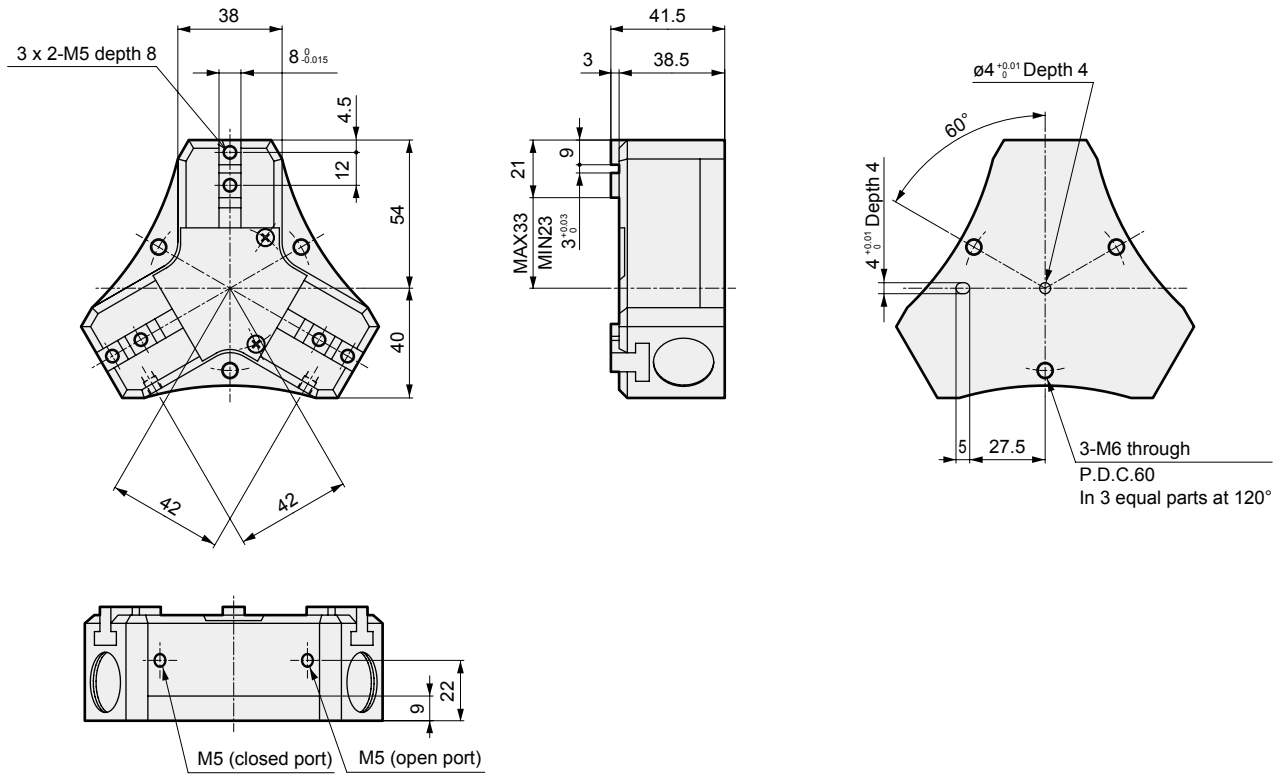

● CKS-20CS-W (with spring) (spring force (3 pcs.) 7.5 to 28N)

● With switch

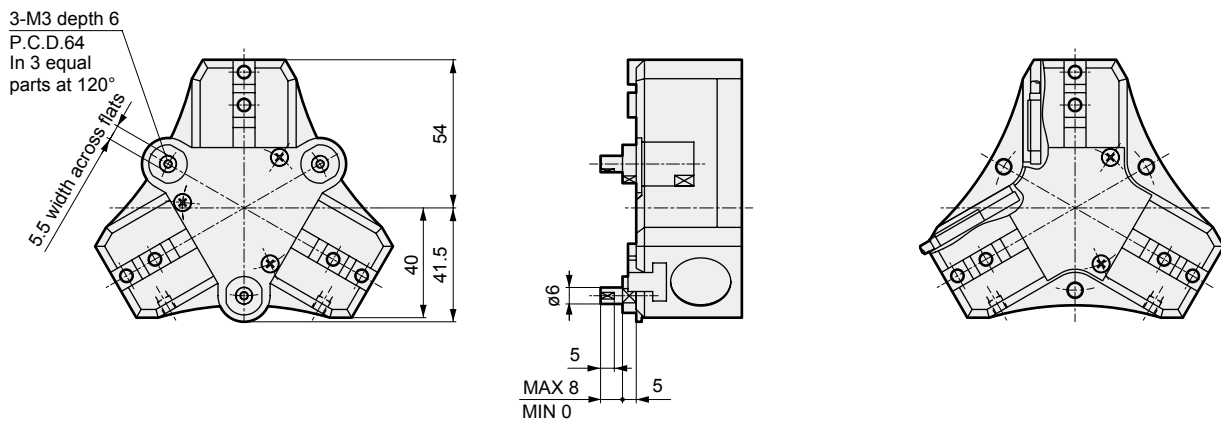

LCM
LCR
LCG
LCW
LCX
STM
STG
STS/STL
STR2
UCA2
ULK*
JSK/M2
JSG
JSC3/JSC4
USSD
UFCD
USC
UB
JSB3
LMB
LML
HCM
HCA
LBC
CAC4
UCAC2
CAC-N
UCAC-N
RCS2
RCC2
PCC
SHC
MCP
GLC
MFC
BBS
RRC
GRC
RV3*
NHS
HRL
LN
Hand
Chuk
MechMtlChuk
ShkAbs
FJ
FK
SpdContr
Ending
CKL2
CKLG2
CKL2-HC
CKH2
CKLB2
CKG
CK
CKA
CKS
CKS-F
CKF
CKJ
CHC

Dimensions



● CKS-25CS standard

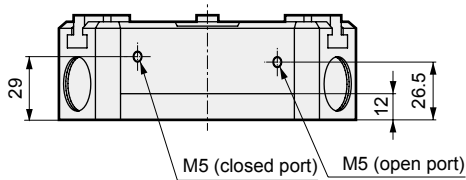
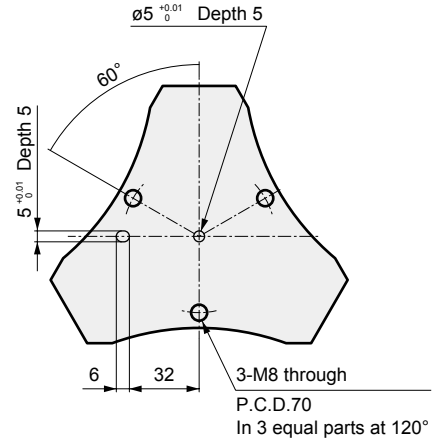
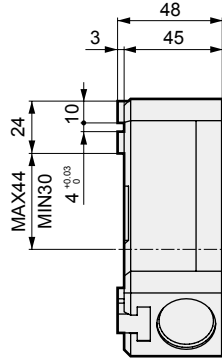
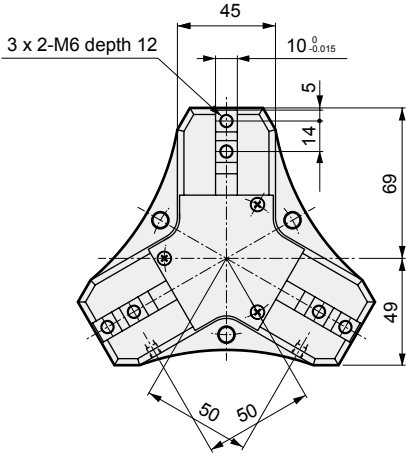

● CKS-25CS-W (with spring) (spring force (3 pcs.) 15 to 39 N)

● With switch

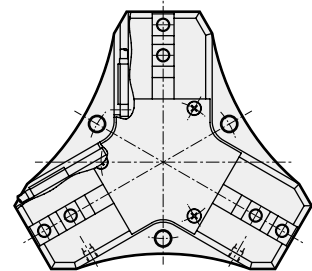
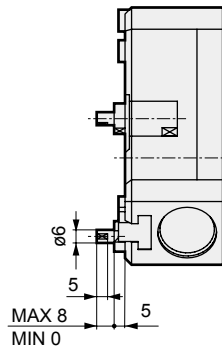
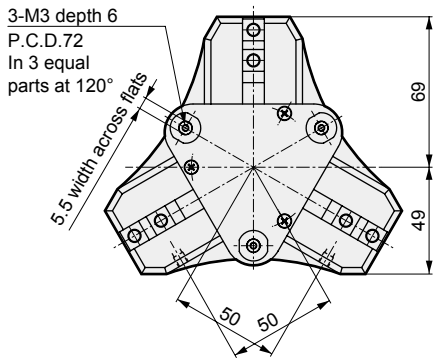

- LCM
- LCR
- LCG
- LCW
- LCX
- STM
- STG
- STS/STL
- STR2
- UCA2
- ULK*
- JSK/M2
- JSG
- JSC3/JSC4
- USSD
- UFCD
- USC
- UB
- JSB3
- LMB
- LML
- HCM
- HCA
- LBC
- CAC4
- UCAC2
- CAC-N
- UCAC-N
- RCS2
- RCC2
- PCC
- SHC
- MCP
- GLC
- MFC
- BBS
- RRC
- GRC
- RV3*
- NHS
- HRL
- LN
- Hand
- Chuk**
- MecHnd/Chuk
- ShkAbs
- FJ
- FK
- SpdContr
- Ending
- CKL2
- CKLG2
- CKL2-HC
- CKH2
- CKLB2
- CKG
- CK
- CKA
- CKS**
- CKS-F
- CKF
- CKJ
- CHC

Dimensions

● CKS-32CS standard

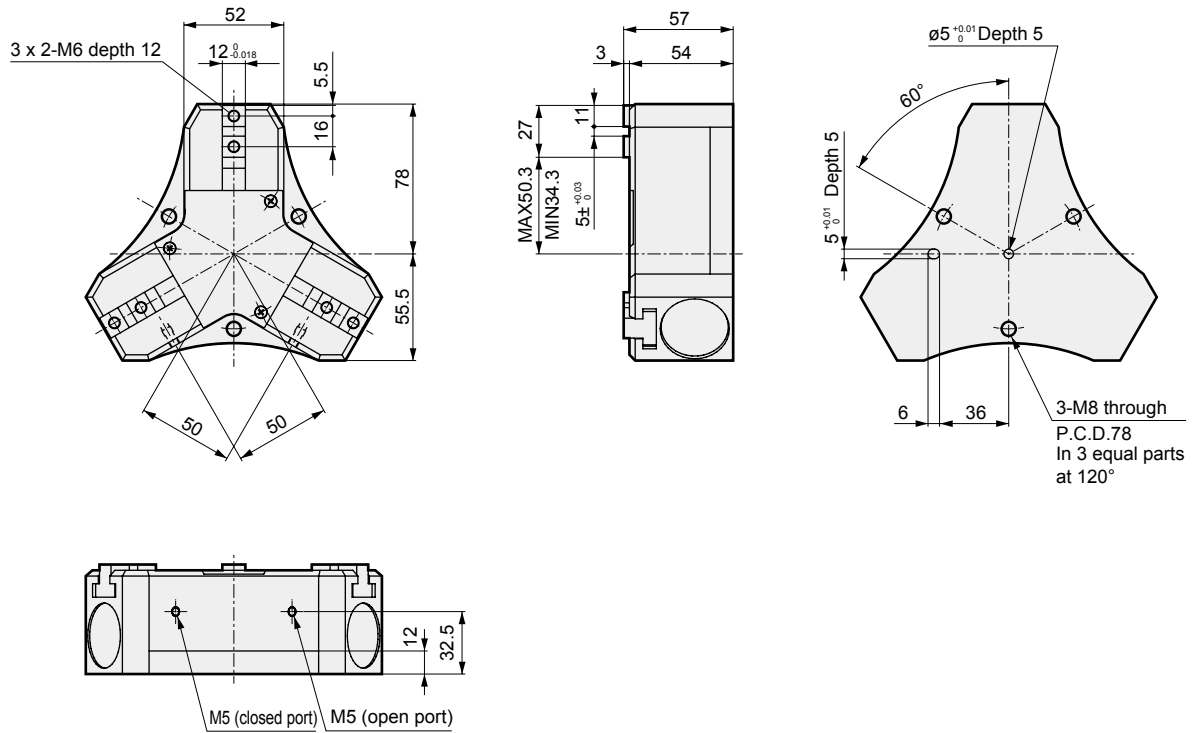

● CKS-32CS-W (with spring) (spring force (3 pcs.) 26 to 67 N)

● With switch

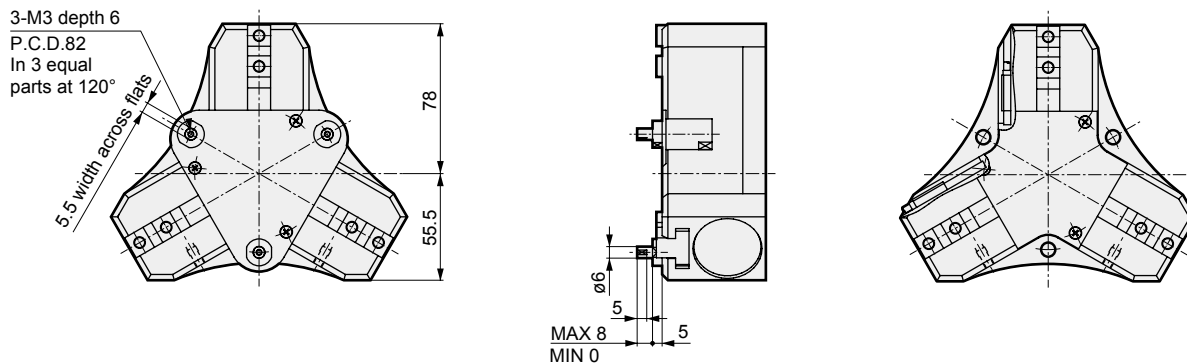

LCM
LCR
LCG
LCW
LCX
STM
STG
STS/STL
STR2
UCA2
ULK*
JSK/M2
JSG
JSC3/JSC4
USSD
UFCD
USC
UB
JSB3
LMB
LML
HCM
HCA
LBC
CAC4
UCAC2
CAC-N
UCAC-N
RCS2
RCC2
PCC
SHC
MCP
GLC
MFC
BBS
RRC
GRC
RV3*
NHS
HRL
LN
Hand
Chuck
MechMtlChuck
ShkAbs
FJ
FK
SpdContr
Ending
CKL2
CKLG2
CKL2-HC
CKH2
CKLB2
CKG
CK
CKA
CKS
CKS-F
CKF
CKJ
CHC

LCM
 LCR
 LCG
 LCW
 LCX
 STM
 STG
 STS/STL
 STR2
 UCA2
 ULK*
 JSK/M2
 JSG
 JSC3/JSC4
 USSD
 UFCD
 USC
 UB
 JSB3
 LMB
 LML
 HCM
 HCA
 LBC
 CAC4
 UCAC2
 CAC-N
 UCAC-N
 RCS2
 RCC2
 PCC
 SHC
 MCP
 GLC
 MFC
 BBS
 RRC
 GRC
 RV3*
 NHS
 HRL
 LN
 Hand
Chuk
 MechHnd/Chuk
 ShkAbs
 FJ
 FK
 SpdContr
 Ending



Thin chuck (hollow)

CKS-F Series

● Operating stroke length: 16, 20, 28, 32, 50 mm

Double acting



Specifications

1 MPa ≈ 145.0 psi, 1 MPa = 10 bar

Item		CKS-F				
Size		16CS	20CS	25CS	32CS	50CS
Actuation		Double acting				
Working fluid		Compressed air				
Max. working pressure MPa		0.7 (≈101 psi, 7 bar)				
Min. working pressure MPa		0.2 (≈29 psi, 2 bar)				
Ambient temperature °C		5 (41°F) to 60 (140°F)				
Port size		M5				
Operating stroke length mm		16	20	28	32	50
Bore size	Open direction	ø12 x 3	ø16 x 3	ø20 x 3	ø25 x 3	ø40 x 3
	Closed direction	ø16 x 3	ø20 x 3	ø25 x 3	ø32 x 3	ø50 x 3
Volumetric capacity (reciprocating) cm ³		7.6	15.5	33.8	62.2	242
Repeatability mm		±0.01				
Weight kg		0.40	0.63	1.14	1.8	5.76
Lubrication		Not required (use turbine oil class 1 ISO VG32 if necessary for lubrication)				

Switch specifications

Item	Proximity 2-wire	Proximity 3-wire
	T2H/V	T3H/V
Applications	Dedicated for programmable controller	For programmable controller, relay
Output method	-	NPN output
Power supply voltage	-	10 to 28 VDC
Load voltage/current	10 to 30 VDC, 5 to 20 mA (*1)	30 VDC or less, 100 mA or less
Display lamp	LED (Lit when ON)	
Leakage current	1 mA or less	10 µA or less
Weight	1 m: 18 g 3 m: 49 g 5 m: 80 g	

*1 : The above max. load current is 20 mA at 25°C. The current is lower than 20 mA if the operating ambient temperature around the switch is higher than 25°C. (5 to 10 mA at 60°C)

*2 : Refer to Ending Page 1 for detailed switch specifications and dimensions.

CKL2
 CKLG2
 CKL2-HC
 CKH2
 CKLB2
 CKG
 CK
 CKA
 CKS
CKS-F
 CKF
 CKJ
 CHC

How to order

Without switch (built-in magnet for switch)

CKS-F - **16CS** - **Y1**

With switch (built-in magnet for switch)

CKS-F - **16CS** - **Y1** - **T2H** - **R**

Model No.

A Size

B Option
*1, *2

C Switch model No.

D Switch quantity

Code	Description
A Size	
16CS	
20CS	
25CS	
32CS	
50CS	
B Option	
Blank	Standard (double acting)
Y1	With attachment Material: S50C
Y2	With attachment Material: MC nylon
C Switch model No.	
Lead wire	Lead wire
Straight	Radial
T2H*	T2V*
T3H*	T3V*
	Contact
	Proximity
	Voltage
	AC
	DC
	Display
	Lead wire
	1-color
	display
	2-wire
	3-wire
* Lead wire length	
Blank	1 m (standard)
3	3 m (option)
5	5 m (option)
D Switch quantity	
R	1 on open side
H	1 on closed side
D	2

⚠ Precautions for model No. selection

*1: Refer to pages 1868 and 1869 for the dimensions and compatible models of the attachment.

When ordered as an option, three are included at shipment.

*2: Attachment cannot be selected for CKS-F-50CS.

[Example of model No.]

CKS-F-16CS-Y1-T2H-R

Thin chuck

- A** Size : 16CS
- B** Option : With attachment, material S50C
- C** Switch model No. : Proximity T2H switch, lead wire 1 m
- D** Switch quantity : One on open side

How to order switch

SW - **T2H***

Switch model No.
(Item **C** above)

LCM
LCR
LCG
LCW
LCX
STM
STG
STS/STL
STR2
UCA2
ULK*
JSK/M2
JSG
JSC3/JSC4
USSD
UFCD
USC
UB
JSB3
LMB
LML
HCM
HCA
LBC
CAC4
UCAC2
CAC-N
UCAC-N
RCS2
RCC2
PCC
SHC
MCP
GLC
MFC
BBS
RRC
GRC
RV3*
NHS
HRL
LN
Hand
Chuk
MechHnd/Chuk
ShkAbs
FJ
FK
SpdContr
Ending

CKL2
CKLG2
CKL2-HC
CKH2
CKLB2
CKG
CK
CKA
CKS
CKS-F
CKF
CKJ
CHC

Internal structure and parts list

● CKS-F-16CS to 50CS

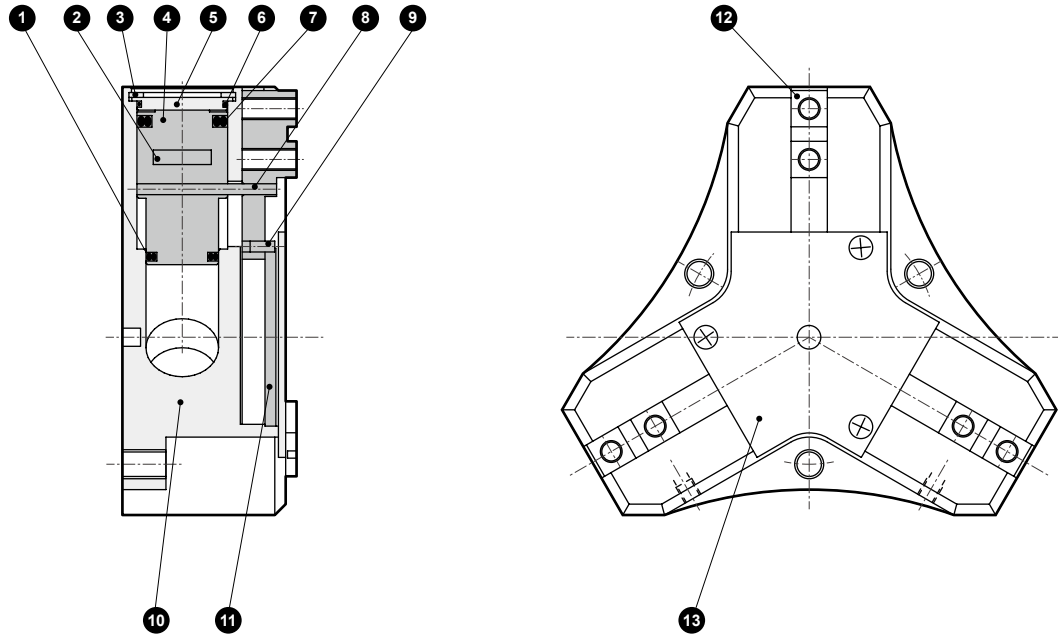

Cannot be disassembled

No.	Part name	Material	Remarks	No.	Part name	Material	Remarks
1	Piston seal B	Nitrile rubber		8	Operation shaft A	Steel alloy	
2	Magnet			9	Operation shaft B	Steel alloy	
3	C type snap ring	Stainless steel		10	Body	Aluminum alloy	
4	Piston	Aluminum alloy		11	Link	Steel	
5	Cylinder guard	Aluminum alloy		12	Finger	Steel	
6	Cylinder sealant	Nitrile rubber		13	Center guard	Stainless steel	
7	Piston seal A	Nitrile rubber					

LCM
LCR
LCG
LCW
LCX
STM
STG
STS/STL
STR2
UCA2
ULK*
JSK/M2
JSG
JSC3/JSC4
USSD
UFCD
USC
UB
JSB3
LMB
LML
HCM
HCA
LBC
CAC4
UCAC2
CAC-N
UCAC-N
RCS2
RCC2
PCC
SHC
MCP
GLC
MFC
BBS
RRC
GRC
RV3*
NHS
HRL
LN
Hand
Chuk
MecHnd/Chuk
ShkAbs
FJ
FK
SpdContr
Ending
CKL2
CKLG2
CKL2-HC
CKH2
CKLB2
CKG
CK
CKA
CKS
CKS-F
CKF
CKJ
CHC

Gripping power performance data

- Gripping power represents the thrust (per one finger) in the arrow direction shown in the figure.
- The gripping power in the opening/closing directions with one finger length ℓ of the hand with a supply pressure of 0.3, 0.5 and 0.7 MPa is shown.
 - Open direction (←) ----- (shown with broken line)
 - Closed direction (→) ————— (shown with continuous line)

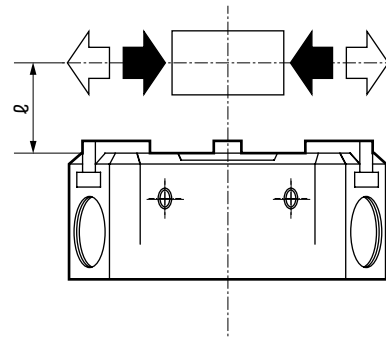

● CKS-F-16CS

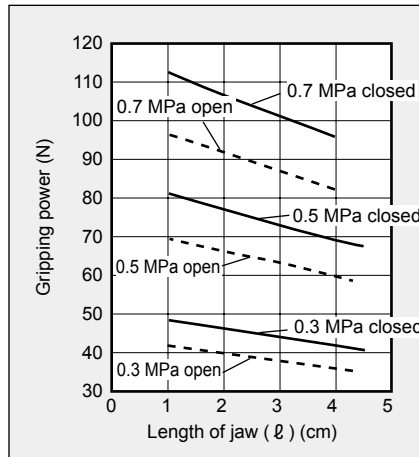

● CKS-F-20CS

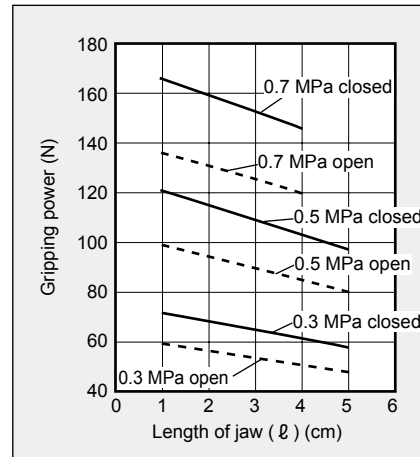

● CKS-F-25CS

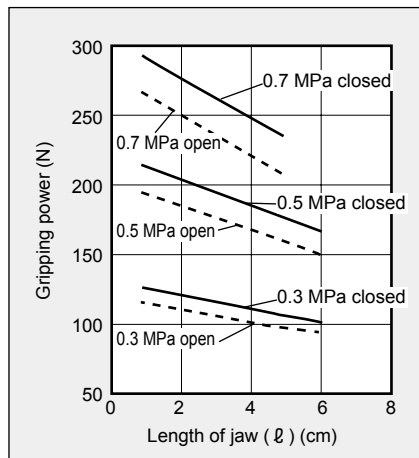

● CKS-F-32CS

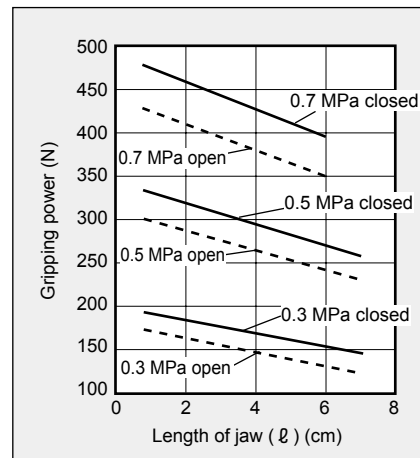

● CKS-F-50CS

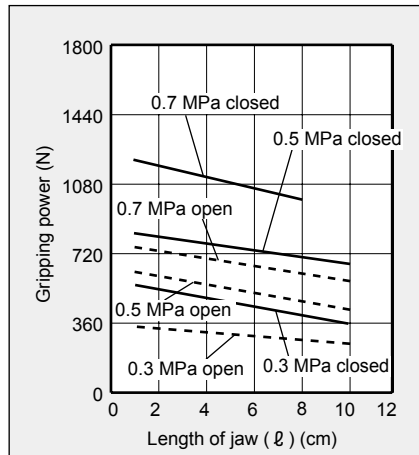

(Note) For selection, see page 1872 for design and selection precautions.

LCM
LCR
LCG
LCW
LCX
STM
STG
STS/STL
STR2
UCA2
ULK*
JSK/M2
JSG
JSC3/JSC4
USSD
UFCD
USC
UB
JSB3
LMB
LML
HCM
HCA
LBC
CAC4
UCAC2
CAC-N
UCAC-N
RCS2
RCC2
PCC
SHC
MCP
GLC
MFC
BBS
RRC
GRC
RV3*
NHS
HRL
LN
Hand
Chuk
MechHnd/Chuk
ShkAbs
FJ
FK
SpdContr
Ending
CKL2
CKLG2
CKL2-HC
CKH2
CKLB2
CKG
CK
CKA
CKS
CKS-F
CKF
CKJ
CHC

CKS-F Series

Dimensions



● CKS-F-16CS

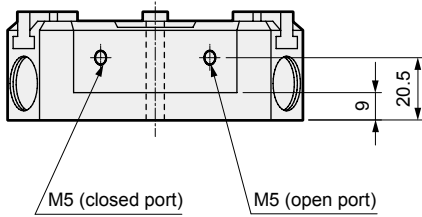
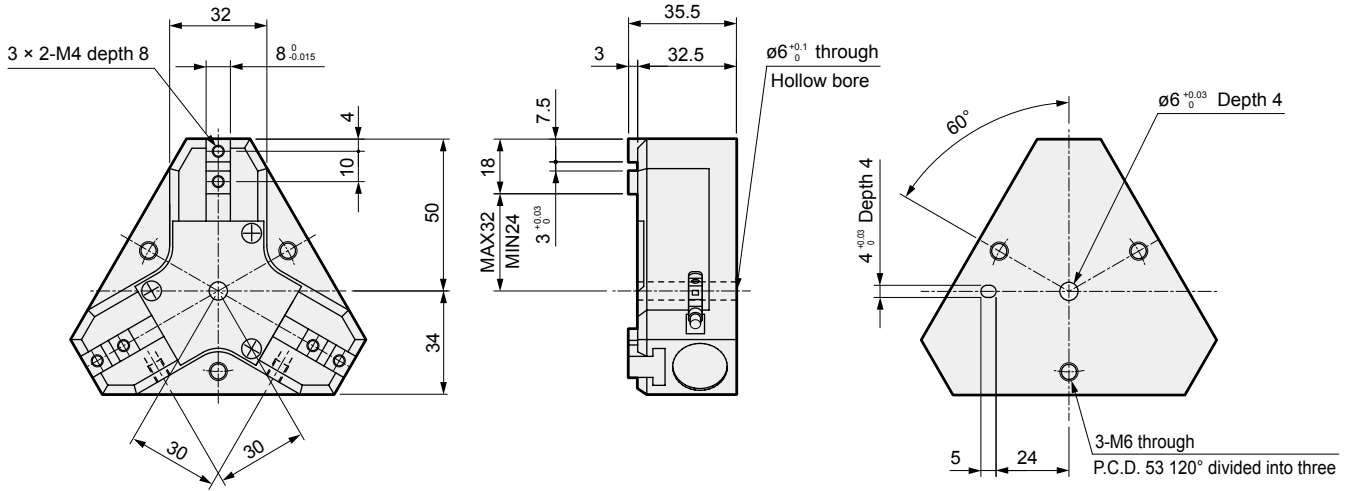

● With switch

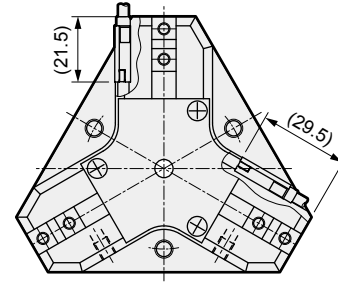

● CKS-F-20CS

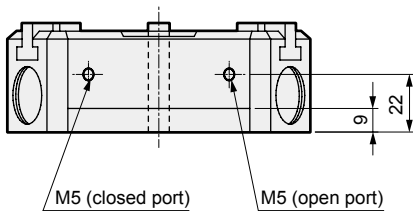
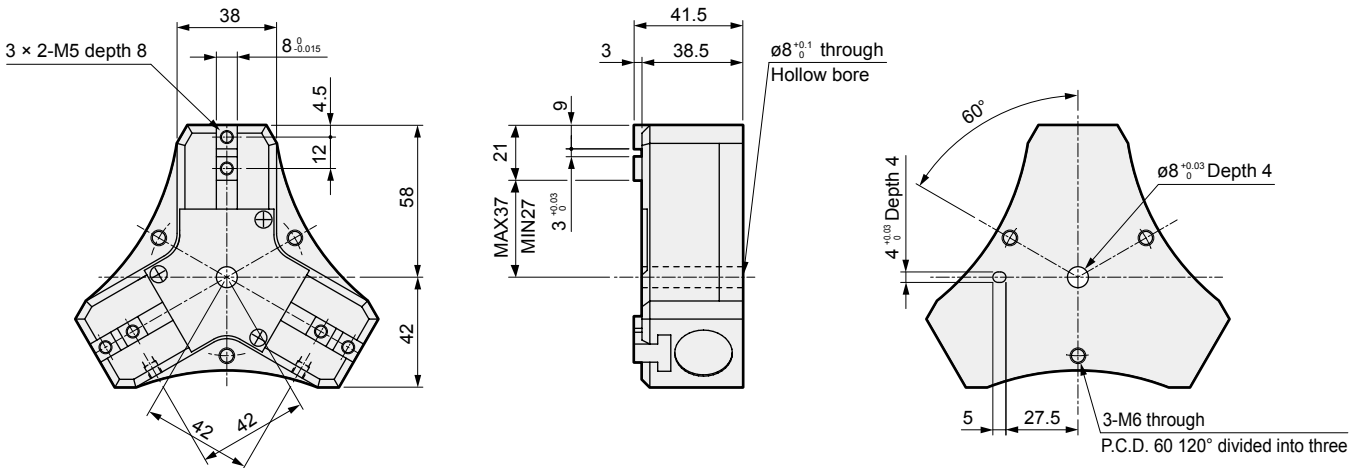

● With switch

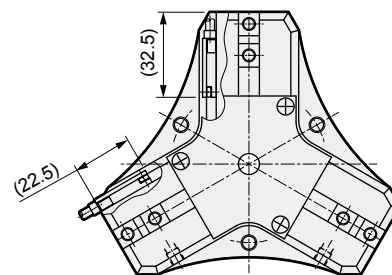

LCM
LCR
LCG
LCW
LCX
STM
STG
STS/STL
STR2
UCA2
ULK*
JSK/M2
JSG
JSC3/JSC4
USSD
UFCD
USC
UB
JSB3
LMB
LML
HCM
HCA
LBC
CAC4
UCAC2
CAC-N
UCAC-N
RCS2
RCC2
PCC
SHC
MCP
GLC
MFC
BBS
RRC
GRC
RV3*
NHS
HRL
LN
Hand
Chuk
MechHnd/Chuk
ShkAbs
FJ
FK
SpdContr
Ending
CKL2
CKLG2
CKL2HC
CKH2
CKLB2
CKG
CK
CKA
CKS
CKS-F
CKF
CKJ
CHC

Dimensions

● CKS-F-25CS

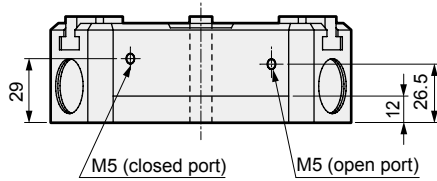
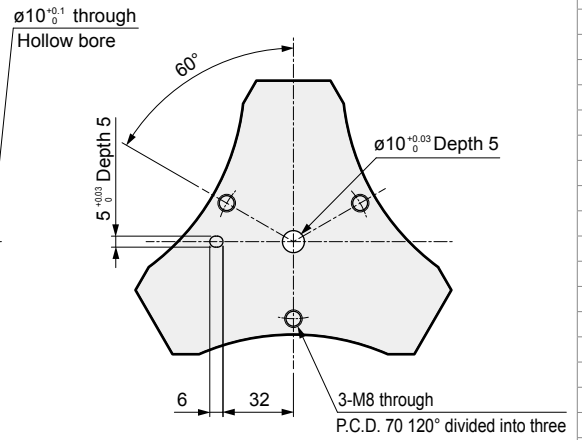
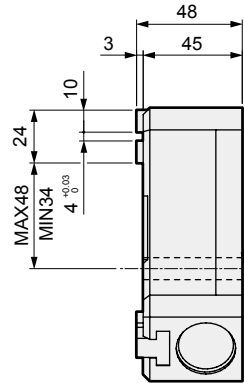
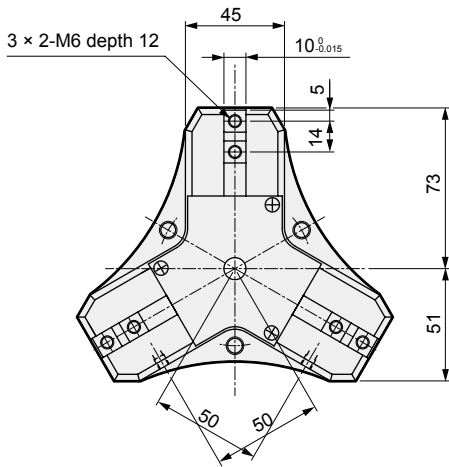

● With switch

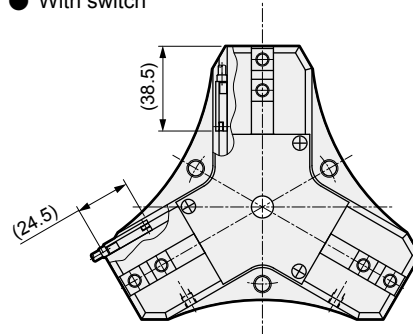

● CKS-F-32CS

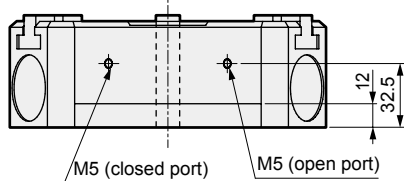
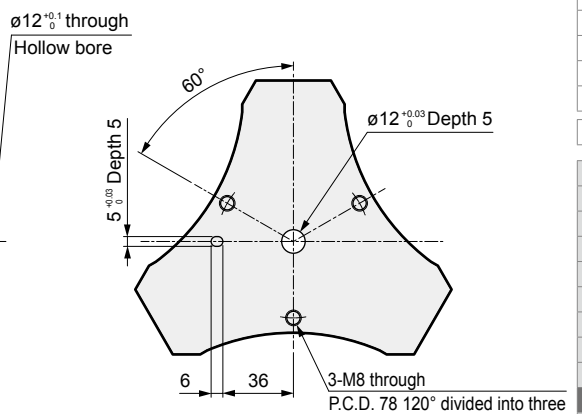
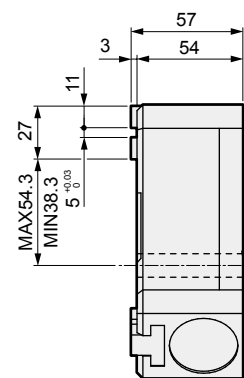
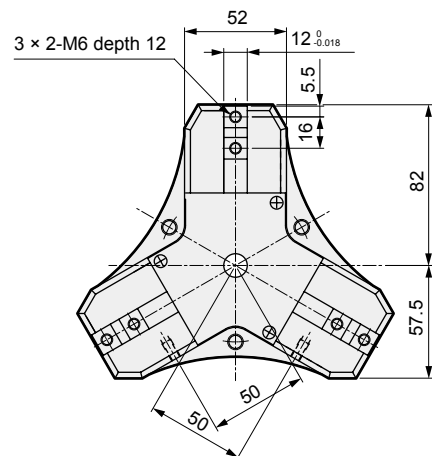

● With switch

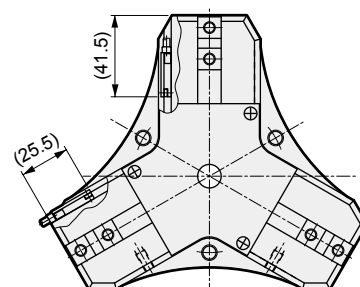

LCM
LCR
LCG
LCW
LCX
STM
STG
STS/STL
STR2
UCA2
ULK*
JSK/M2
JSG
JSC3/JSC4
USSD
UFCD
USC
UB
JSB3
LMB
LML
HCM
HCA
LBC
CAC4
UCAC2
CAC-N
UCAC-N
RCS2
RCC2
PCC
SHC
MCP
GLC
MFC
BBS
RRC
GRC
RV3*
NHS
HRL
LN
Hand
Chuck
MechMtlChuck
ShkAbs
FJ
FK
SpdContr
Ending
CKL2
CKLG2
CKL2-HC
CKH2
CKLB2
CKG
CK
CKA
CKS
CKS-F
CKF
CKJ
CHC

CKS-F Series

Dimensions



● CKS-F-50CS

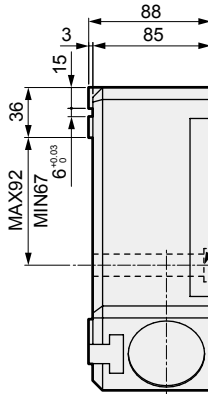
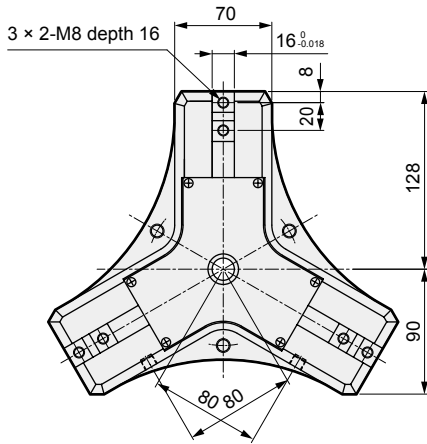

$\varnothing 16_{+0}^{+0.1}$ through
Hollow bore

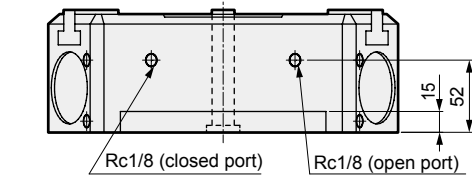
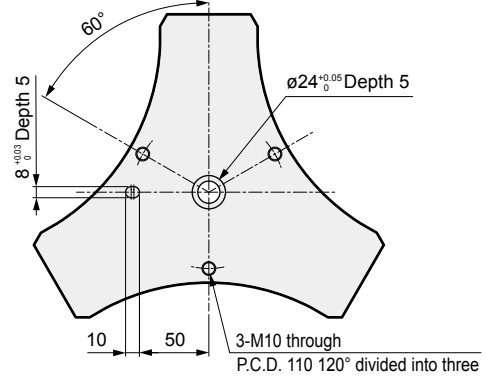

● With switch

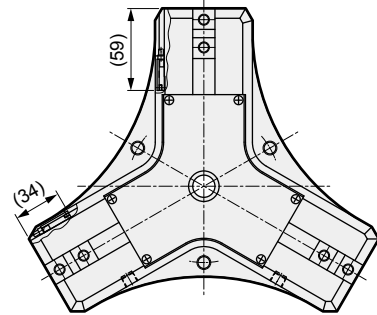

- LCM
- LCR
- LCG
- LCW
- LCX
- STM
- STG
- STS/STL
- STR2
- UCA2
- ULK*
- JSK/M2
- JSG
- JSC3/USC4
- USSD
- UFCD
- USC
- UB
- JSB3
- LMB
- LML
- HCM
- HCA
- LBC
- CAC4
- UCAC2
- CAC-N
- UCAC-N
- RCS2
- RCC2
- PCC
- SHC
- MCP
- GLC
- MFC
- BBS
- RRC
- GRC
- RV3*
- NHS
- HRL
- LN
- Hand
- Chuk**
- MecHnd/Chuk
- ShkAbs
- FJ
- FK
- SpdContr
- Ending

- CKL2
- CKLG2
- CKL2-HC
- CKH2
- CKLB2
- CKG
- CK
- CKA
- CKS
- CKS-F**
- CKF
- CKJ
- CHC