

LCM  
LCR  
LCG  
LCW  
LCX  
STM  
STG  
STS/STL  
STR2  
UCA2  
ULK\*  
JSK/M2  
JSG  
JSC3/JSC4  
USSD  
UFCD  
USC  
UB  
JSB3  
LMB  
LML  
HCM  
HCA  
LBC  
CAC4  
UCAC2  
CAC-N  
UCAC-N  
RCS2  
RCC2  
PCC  
SHC  
MCP  
GLC  
MFC  
BBS  
RRC  
GRC  
RV3\*  
NHS  
HRL  
LN  
Hand  
Chuk  
MechHnd/Chuk  
ShkAbs  
FJ  
FK  
SpdContr  
Ending



Ultra long stroke chuck Double acting  
(standard/short stroke)

# CKJ Series

● Operational stroke length: Standard 80, 130 mm  
Short stroke 40, 65 mm

Double acting



## Specifications

Item	CKJ					
	16CS		40CS		63CS	
Size	Standard	S1	Standard	S1	Standard	S1
Bore size mm	ø12×6		ø32×6		ø50×6	
Working fluid	Compressed air					
Max. working pressure MPa	0.7 (≈100 psi, 7 bar)					
Min. working pressure MPa	0.3 (≈44 psi, 3 bar)					
Ambient temperature °C	5 (41°F) to 60 (140°F)					
Port size	M5				Rc1/8	
Operating stroke length mm	80	40	80	40	130	65
Rod diameter mm	ø6		ø12		ø14	
Volumetric capacity (reciprocating) cm <sup>3</sup>	47.4	24.0	358.8	179.4	1471.2	735.6
Repeatability mm	±0.1					
Weight kg	2.38	1.35	5.6	4.2	18.5	13
Lubrication	Not required (use turbine oil class 1 ISO VG32 if necessary for lubrication)					

## Switch specifications

Item	Proximity 2-wire	Proximity 3-wire
	T2H/V	T3H/V
Applications	Dedicated for programmable controller	For programmable controller, relay
Output method	-	NPN output
Power supply voltage	-	10 to 28 VDC
Load voltage/current	10 to 30 VDC, 5 to 20 mA (*1)	30 VDC or less, 100 mA or less
Indicator lamp	LED (Lit when ON)	
Leakage current	1 mA or less	10 µA or less
Weight	1 m:18 g 3 m:49 g 5 m:80 g	

\*1 : The above max. load current is 20 mA at 25°C. The current is lower than 20 mA if the operating ambient temperature around the switch is higher than 25°C. (5 to 10 mA at 60°C)

\*2 : Refer to Ending Page 1 for detailed switch specifications and dimensions.

CKL2  
CKLG2  
CKL2-HC  
CKH2  
CKLB2  
CKG  
CK  
CKA  
CKS  
CKS-F  
CKF  
CKJ  
CHC

## How to order

Without switch (built-in magnet for switch)

**CKJ - 16CS - S1**

With switch (built-in magnet for switch)

**CKJ - 16CS - S1 - T2H - R**

**A** Size

**B** Option

**C** Switch model No.

**D** Switch quantity

Code	Description					
<b>A Size</b>						
16CS						
40CS						
63CS						
<b>B Option</b>						
Blank	Standard					
S1	Short stroke					
<b>C Switch model No.</b>						
Axial lead wire	Radial lead wire	Contact	Voltage		Display	Lead wire
			AC	DC		
T2H*	T2V*	Proximity		●	1-color	2-wire
T3H*	T3V*		●		display	3-wire
<b>* Lead wire length</b>						
Blank	1 m (standard)					
3	3 m (option)					
5	5 m (option)					
<b>D Switch quantity</b>						
R	1 on open side					
H	1 on closed side					
D	2					

[Example of model No.]

**CKJ-16CS-S1-T2H-R**

Model: Ultra long stroke chuck

- A** Size : 16CS
- B** Option : Short stroke
- C** Switch model No. : Proximity T2H switch, lead wire 1 m
- D** Switch quantity : 1 on open side

## How to order switch

**SW - T2H**

Switch model No.  
(Item **C** above)

LCM
LCR
LCG
LCW
LCX
STM
STG
STS/STL
STR2
UCA2
ULK*
JSK/M2
JSG
JSC3/JSC4
USSD
UFCD
USC
UB
JSB3
LMB
LML
HCM
HCA
LBC
CAC4
UCAC2
CAC-N
UCAC-N
RCS2
RCC2
PCC
SHC
MCP
GLC
MFC
BBS
RRC
GRC
RV3*
NHS
HRL
LN
Hand
<b>Chuck</b>
MechMtlChuck
ShkAbs
FJ
FK
SpdContr
Ending
CKL2
CKLG2
CKL2-HC
CKH2
CKLB2
CKG
CK
CKA
CKS
CKS-F
CKF
<b>CKJ</b>
CHC

## Internal structure and parts list

● CKJ-16CS

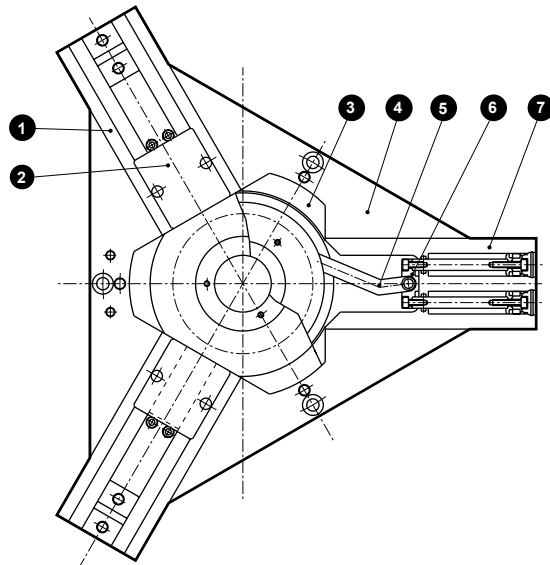
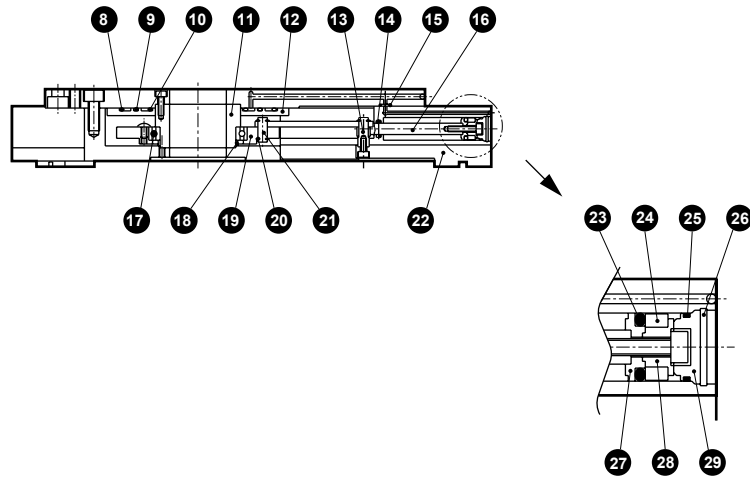

● CKJ-40CS

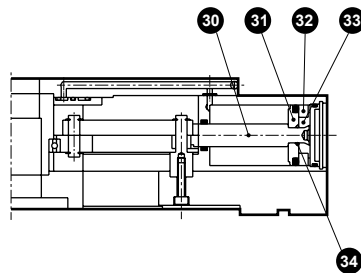

Cannot be disassembled

- LCM
- LCR
- LCG
- LCW
- LCX
- STM
- STG
- STS/STL
- STR2
- UCA2
- ULK\*
- JSK/M2
- JSG
- JSC3/JSC4
- USSD
- UFCD
- USC
- UB
- JSB3
- LMB
- LML
- HCM
- HCA
- LBC
- CAC4
- UCAC2
- CAC-N
- UCAC-N
- RCS2
- RCC2
- PCC
- SHC
- MCP
- GLC
- MFC
- BBS
- RRC
- GRC
- RV3\*
- NHS
- HRL
- LN
- Hand
- Chuk**
- MecHnd/Chuk
- ShkAbs
- FJ
- FK
- SpdContr
- Ending

- CKL2
- CKLG2
- CKL2-HC
- CKH2
- CKLB2
- CKG
- CKJ**
- CK
- CKA
- CKS
- CKS-F
- CKF
- CKJ
- CHC

### Internal structure and parts list

● CKJ-63CS

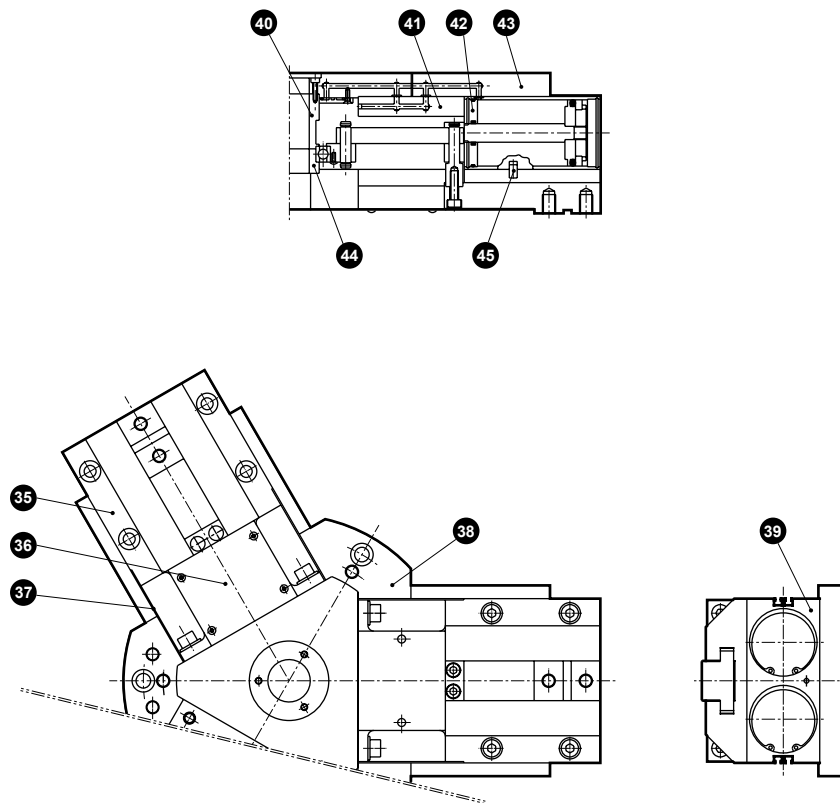

Cannot be disassembled

### Parts list

No.	Part name	Material	Remarks	No.	Part name	Material	Remarks
1	Cylinder body B	Aluminum alloy		24	Magnet		
2	Cover	Stainless steel		25	Cylinder sealant	Nitrile rubber	
3	Center block	Aluminum alloy		26	C type snap ring	Carbon steel	
4	Base	Aluminum alloy		27	Piston A	Aluminum alloy	
5	Link	Stainless steel	63CS is carbon steel	28	Piston B	Aluminum alloy	63CS is stainless steel
6	Connection block	Stainless steel	63CS is carbon steel	29	Cylinder guard	Acetal resin	63CS is aluminum alloy
7	Cylinder body A	Aluminum alloy		30	Piston rod	Stainless steel	
8	O-ring	Nitrile rubber		31	Piston A	Aluminum alloy	
9	O-ring	Nitrile rubber		32	Magnet		
10	O-ring	Nitrile rubber		33	Piston B	Aluminum alloy	
11	Hollow ring	Aluminum alloy		34	O-ring	Nitrile rubber	
12	Piping plate	Aluminum alloy		35	Body	Aluminum alloy	
13	Operation pin	Stainless steel	63CS is carbon steel	36	Front cover	Stainless steel	
14	Rod sealant	Nitrile rubber		37	Side cover	Stainless steel	
15	O-ring	Nitrile rubber		38	Base 1	Aluminum alloy	
16	Piston rod	Stainless steel		39	Cylinder	Aluminum alloy	
17	Bearing			40	Hollow ring 1	Aluminum alloy	
18	Collar	Carbon steel		41	Base 3	Aluminum alloy	
19	Link ring	Aluminum alloy		42	Rod cover	Aluminum alloy	
20	E type snap ring	Carbon steel		43	Base 2	Aluminum alloy	
21	Fulcrum axis	Stainless steel	63CS is carbon steel	44	Hollow ring 2	Aluminum alloy	
22	Finger	Carbon steel		45	Parallel pin	Stainless steel	
23	Piston seal	Nitrile rubber					

LCM
LCR
LCG
LCW
LCX
STM
STG
STS/STL
STR2
UCA2
ULK*
JSK/M2
JSG
JSC3/JSC4
USSD
UFCD
USC
UB
JSB3
LMB
LML
HCM
HCA
LBC
CAC4
UCAC2
CAC-N
UCAC-N
RCS2
RCC2
PCC
SHC
MCP
GLC
MFC
BBS
RRC
GRC
RV3*
NHS
HRL
LN
Hand
<b>Chuk</b>
MechHnd/Chuk
ShkAbs
FJ
FK
SpdContr
Ending
CKL2
CKLG2
CKL2-HC
CKH2
CKLB2
CKG
CK
CKA
CKS
CKS-F
CKF
<b>CKJ</b>
CHC

## Internal structure and parts list

● CKJ-16CS-S1

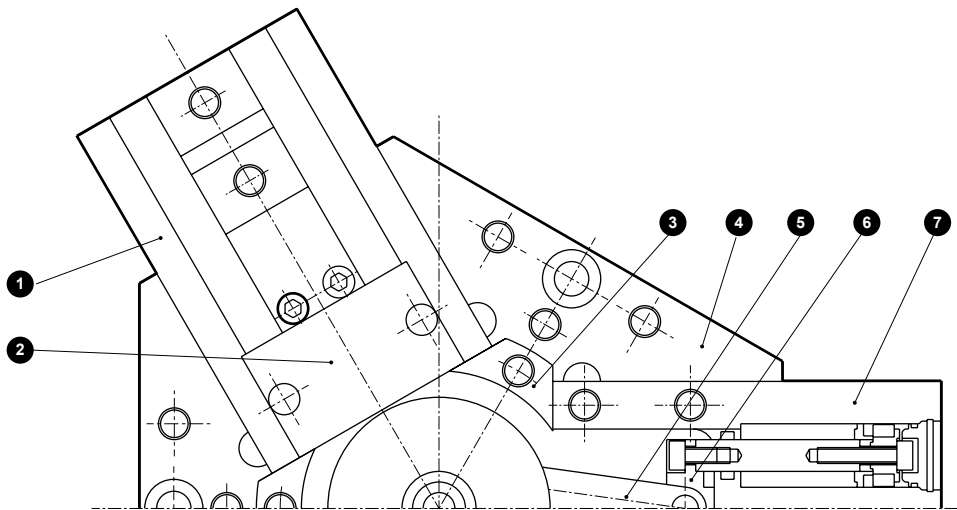
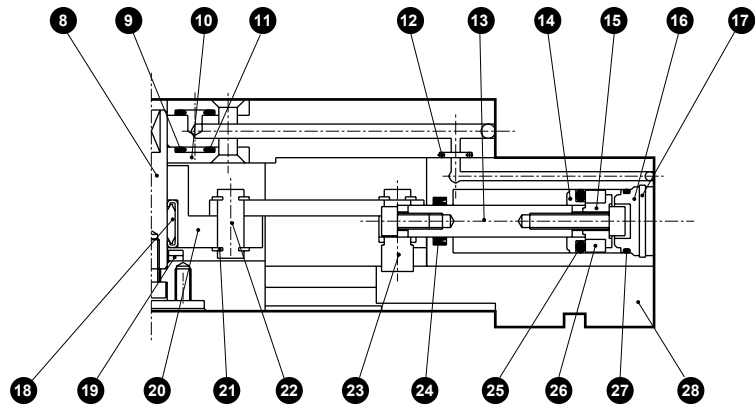

● CKJ-40CS-S1

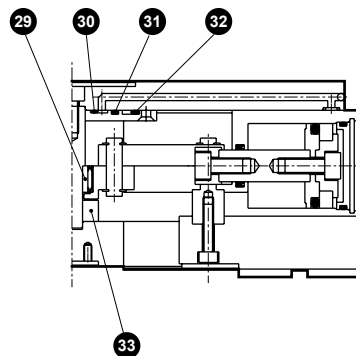

Cannot be disassembled

- LCM
- LCR
- LCG
- LCW
- LCX
- STM
- STG
- STS/STL
- STR2
- UCA2
- ULK\*
- JSK/M2
- JSG
- JSC3/JSC4
- USSD
- UFCD
- USC
- UB
- JSB3
- LMB
- LML
- HCM
- HCA
- LBC
- CAC4
- UCAC2
- CAC-N
- UCAC-N
- RCS2
- RCC2
- PCC
- SHC
- MCP
- GLC
- MFC
- BBS
- RRC
- GRC
- RV3\*
- NHS
- HRL
- LN
- Hand
- Chuk**
- MecHnd/Chuk
- ShkAbs
- FJ
- FK
- SpdContr
- Ending

- CKL2
- CKLG2
- CKL2-HC
- CKH2
- CKLB2
- CKG
- CKJ-40CS-S1
- CK
- CKA
- CKS
- CKS-F
- CKF
- CKJ**
- CHC

### Internal structure and parts list

● CKJ-63CS-S1

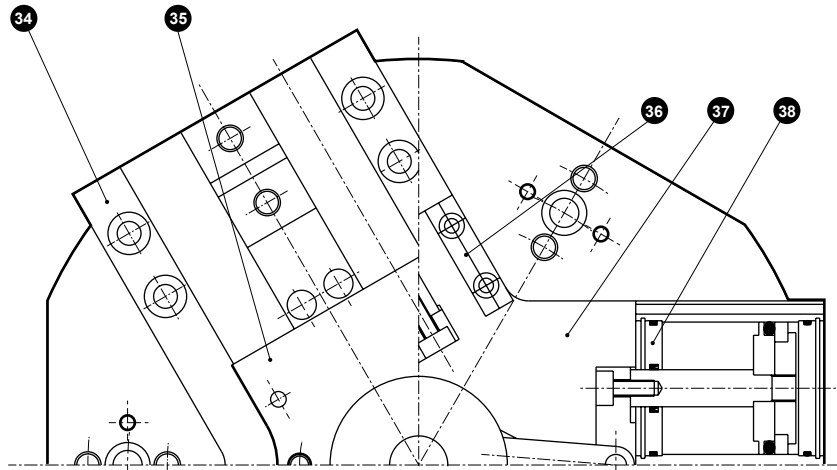
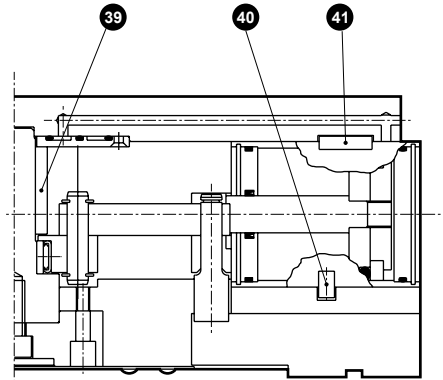

**Cannot be disassembled**

### Parts list

No.	Part name	Material	Remarks	No.	Part name	Material	Remarks
1	Cylinder body B	Aluminum alloy		22	Fulcrum axis	Stainless steel	63CS is carbon steel
2	Cover	Stainless steel		23	Operation pin	Stainless steel	63CS is carbon steel
3	Center block	Aluminum alloy	63CS is carbon steel	24	Rod sealant	Nitrile rubber	
4	Base	Aluminum alloy		25	Piston seal	Nitrile rubber	
5	Link	Stainless steel	63CS is carbon steel	26	Magnet		
6	Connection block	Stainless steel	63CS is carbon steel	27	Cylinder sealant	Nitrile rubber	
7	Cylinder body A	Aluminum alloy		28	Finger	Carbon steel	
8	Shaft	Carbon steel	63CS is aluminum alloy	29	Inner ring		
9	O-ring	Nitrile rubber		30	O-ring	Nitrile rubber	
10	Piping plate	Aluminum alloy		31	O-ring	Nitrile rubber	
11	O-ring	Nitrile rubber		32	O-ring	Nitrile rubber	
12	O-ring	Nitrile rubber		33	Collar	Acetal resin	
13	Piston rod	Stainless steel		34	Body	Aluminum alloy	
14	Piston A	Aluminum alloy		35	Front cover	Stainless steel	
15	Piston B	Aluminum alloy	63CS is stainless steel	36	Side cover	Aluminum alloy	
16	Cylinder guard	Acetal resin	63CS is aluminum alloy	37	Cylinder	Aluminum alloy	
17	C type snap ring	Carbon steel		38	Rod cover	Aluminum alloy	
18	Needle rolling bearing			39	Metal collar	Carbon steel	
19	Washer			40	Parallel pin	Stainless steel	
20	Link ring	Aluminum alloy		41	Double round key	Carbon steel	
21	E type snap ring	Carbon steel					

LCM
LCR
LCG
LCW
LCX
STM
STG
STS/STL
STR2
UCA2
ULK*
JSK/M2
JSG
JSC3/JSC4
USSD
UFCD
USC
UB
JSB3
LMB
LML
HCM
HCA
LBC
CAC4
UCAC2
CAC-N
UCAC-N
RCS2
RCC2
PCC
SHC
MCP
GLC
MFC
BBS
RRC
GRC
RV3*
NHS
HRL
LN
Hand
<b>Chuk</b>
MechHnd/Chuk
ShkAbs
FJ
FK
SpdContr
Ending

CKL2
CKLG2
CKL2-HC
CKH2
CKLB2
CKG
CK
CKA
CKS
CKS-F
CKF
<b>CKJ</b>
CHC

## Gripping power performance data

- Gripping power represents the thrust (per one finger) in the arrow direction shown in the figure.
- The gripping power at a supply pressure 0.3, 0.5, and 0.7 MPa with jaw length  $\ell$  of hand is shown.
  - Open direction (  $\leftarrow$  ) ----- (shown with broken line)
  - Closed direction (  $\rightarrow$  ) ————— (shown with continuous line)

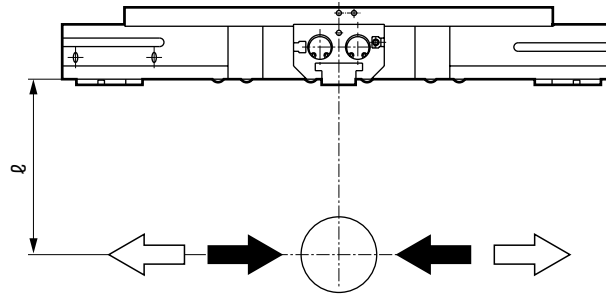

● CKJ-16CS

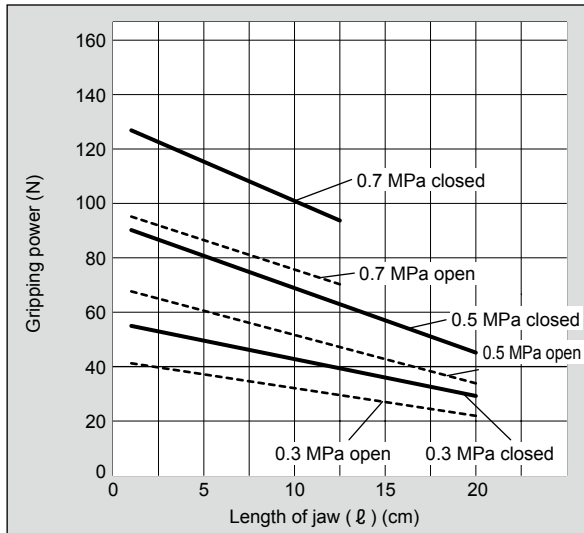

● CKJ-40CS

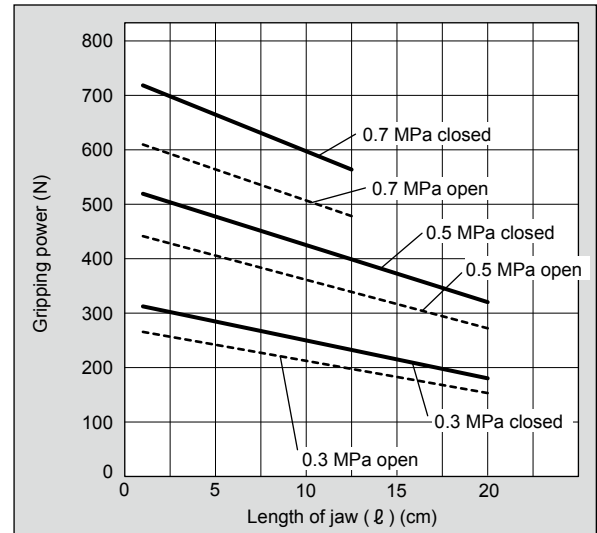

● CKJ-63CS

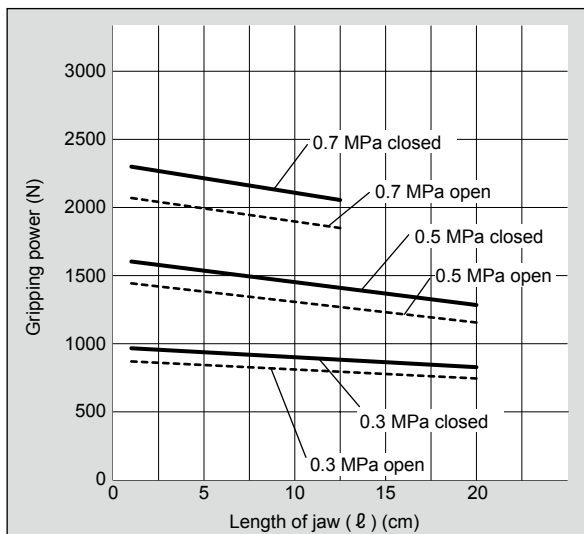

(Note) When making a selection, read the precautions for design and selection on page 1872.

- LCM
- LCR
- LCC
- LCW
- LCC
- STM
- STG
- STS/STL
- STR2
- UCA2
- ULK\*
- JSK/M2
- JSG
- JSC3/JSC4
- USSD
- UFCD
- USC
- UB
- JSB3
- LMB
- LML
- HCM
- HCA
- LBC
- CAC4
- UCAC2
- CAC-N
- UCAC-N
- RCS2
- RCC2
- PCC
- SHC
- MCP
- GLC
- MFC
- BBS
- RRC
- GRC
- RV3\*
- NHS
- HRL
- LN
- Hand
- Chuk**
- MechHnd/Chuk
- ShkAbs
- FJ
- FK
- SpdContr
- Ending

- CKL2
- CKLG2
- CKL2-HC
- CKH2
- CKLB2
- CKG
- CK
- CKA
- CKS
- CKS-F
- CKF
- CKJ**
- CHC

### Dimensions



#### ● CKJ-16CS standard

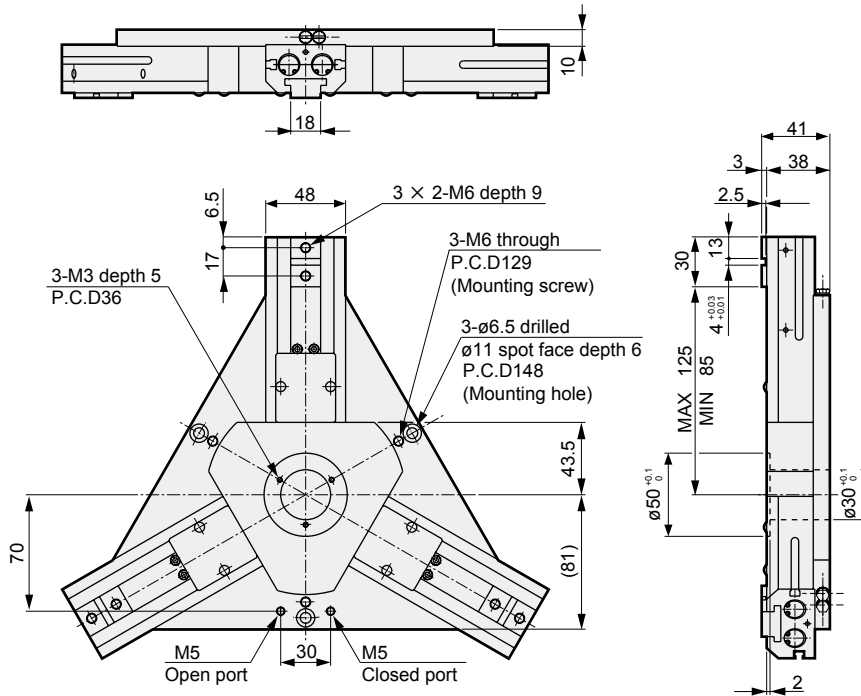

#### ● With switch

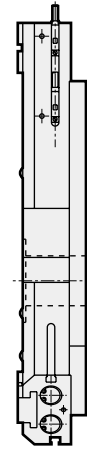

#### ● CKJ-16CS-S1

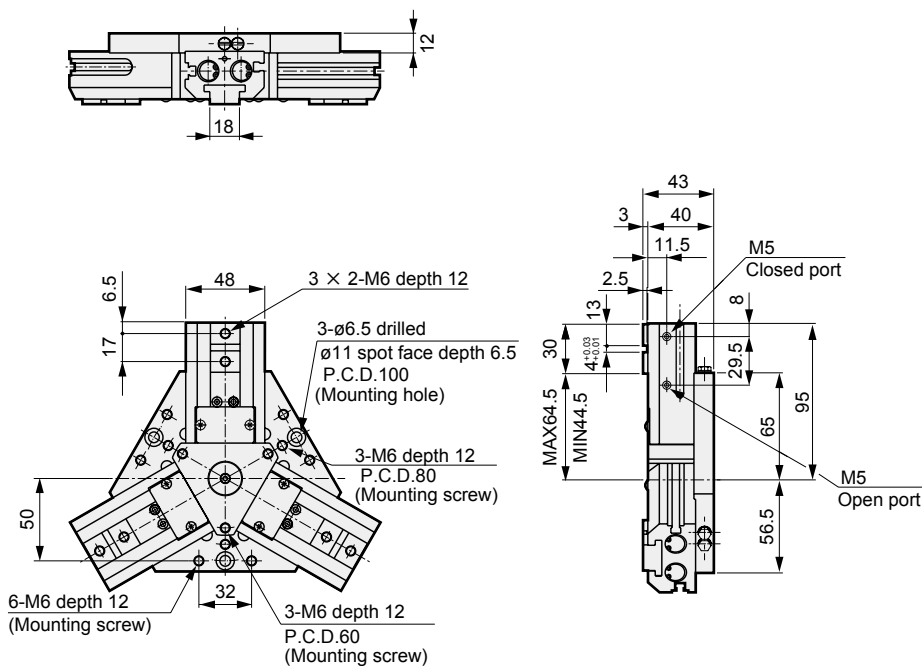

#### ● With switch

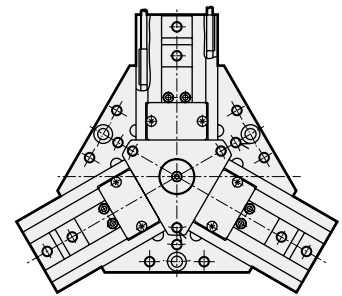

LCM
LCR
LCG
LCW
LCX
STM
STG
STS/STL
STR2
UCA2
ULK*
JSK/M2
JSG
JSC3/JSC4
USSD
UFCD
USC
UB
JSB3
LMB
LML
HCM
HCA
LBC
CAC4
UCAC2
CAC-N
UCAC-N
RCS2
RCC2
PCC
SHC
MCP
GLC
MFC
BBS
RRC
GRC
RV3*
NHS
HRL
LN
Hand
<b>Chuk</b>
MechMtlChuk
ShkAbs
FJ
FK
SpdContr
Ending

CKL2
CKLG2
CKL2-HC
CKH2
CKLB2
CKG
CK
CKA
CKS
CKS-F
CKF
<b>CKJ</b>
CHC



## Dimensions



LCM
LCR
LCG
LCW
L CX
STM
STG
STS/STL
STR2
UCA2
ULK*
JSK/M2
JSG
JSC3/USC4
USSD
UFCD
USC
UB
JSB3
LMB
LML
HCM
HCA
LBC
CAC4
UCAC2
CAC-N
UCAC-N
RCS2
RCC2
PCC
SHC
MCP
GLC
MFC
BBS
RRC
GRC
RV3*
NHS
HRL
LN
Hand
<b>Chuk</b>
MecHnd/Chuk
ShkAbs
FJ
FK
SpdContr
Ending
CKL2
CKLG2
CKL2-HC
CKH2
CKLB2
CKG
CK
CKA
CKS
CKS-F
CKF
<b>CKJ</b>
CHC

### ● CKJ-40CS standard

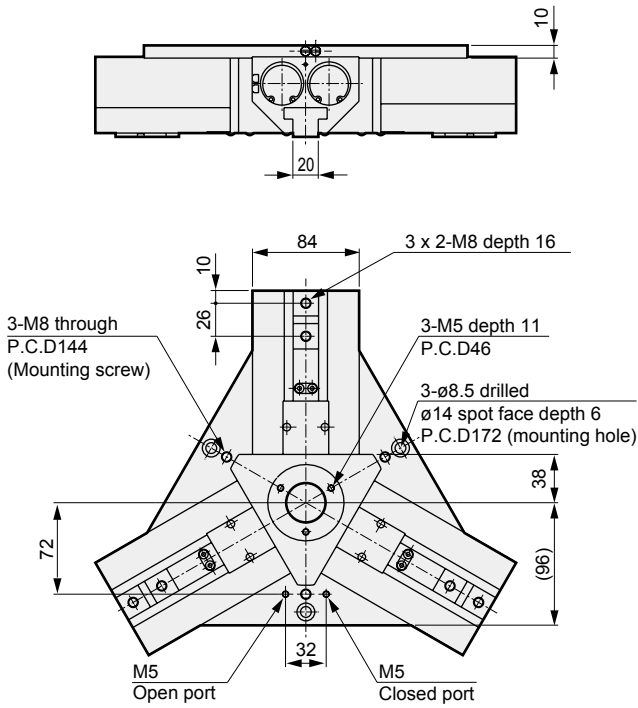

### ● With switch

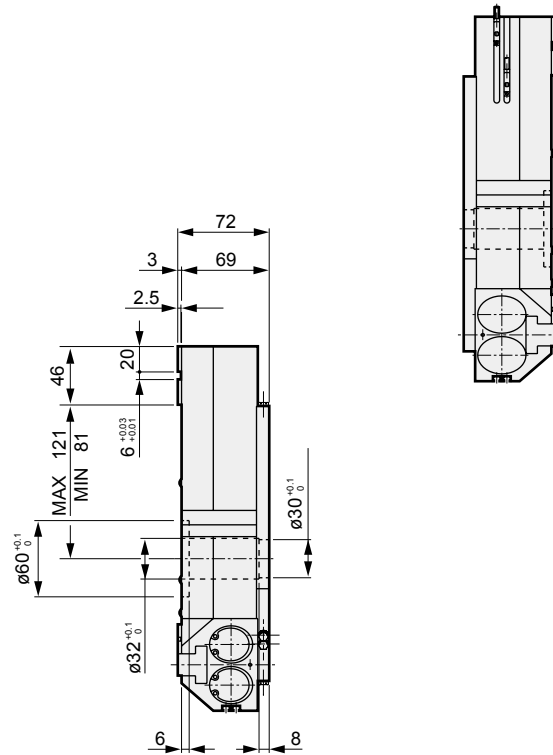

### ● CKJ-40CS-S1

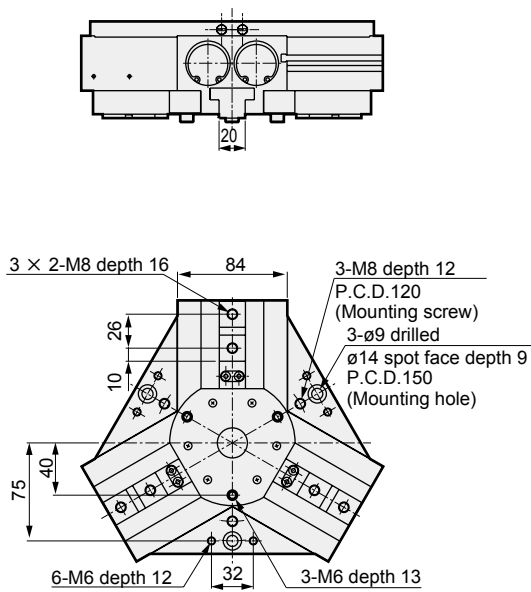

### ● With switch

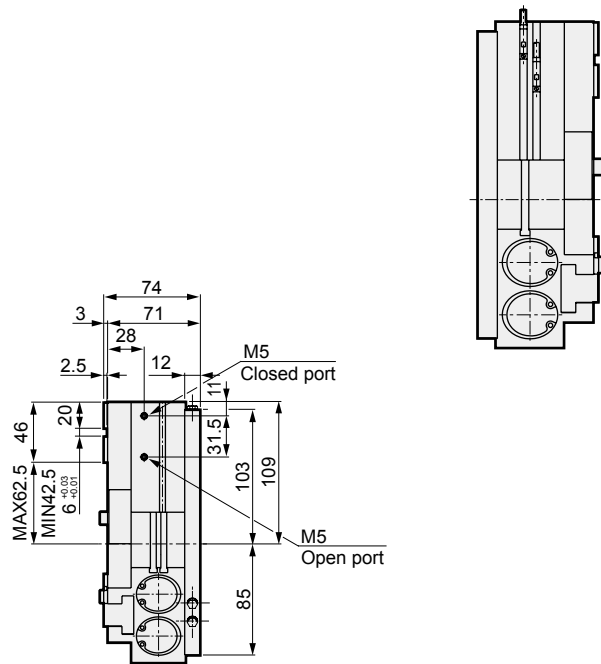

### Dimensions



#### ● CKJ-63CS standard

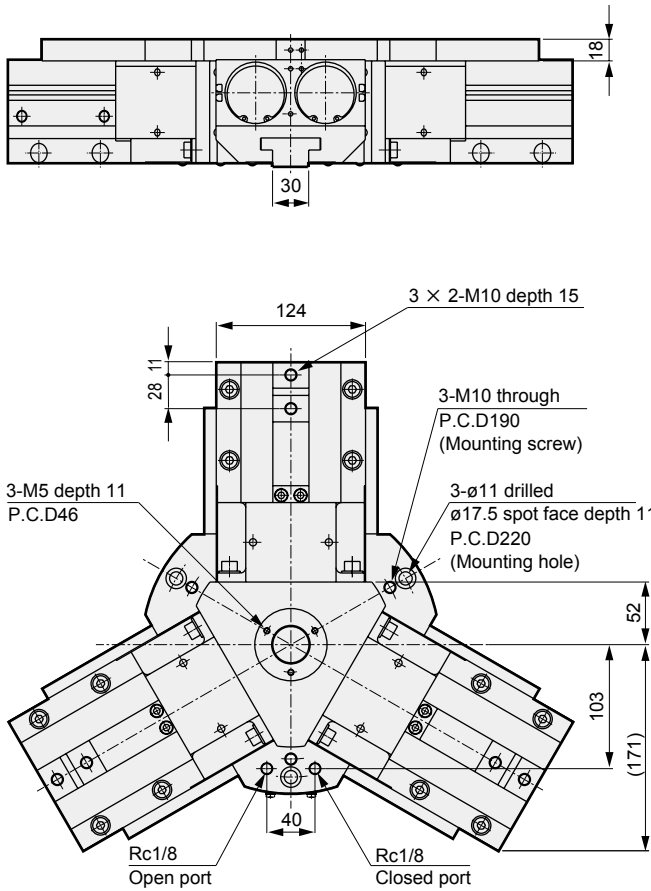

#### ● With switch

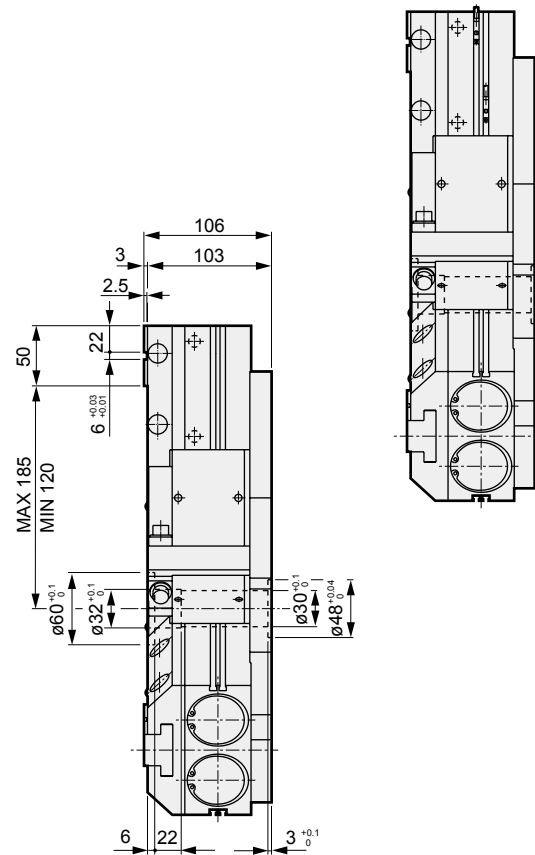

#### ● CKJ-63CS-S1

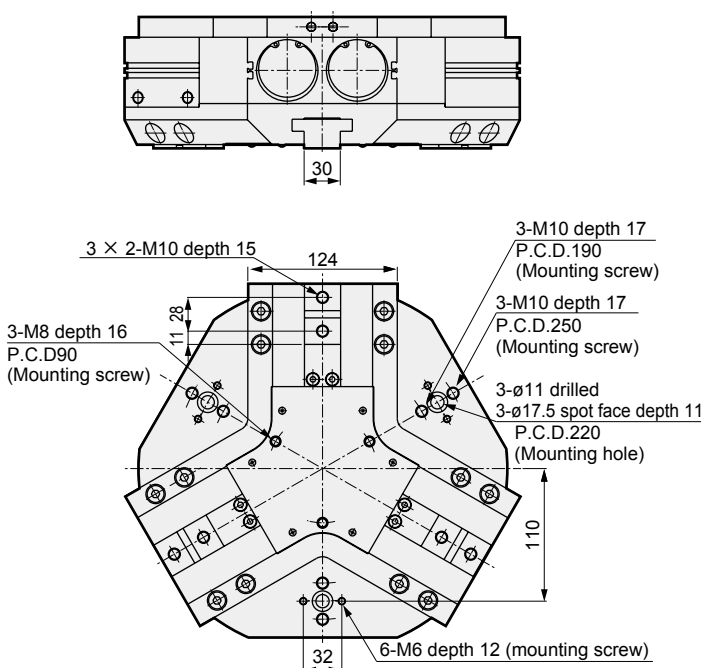

#### ● With switch

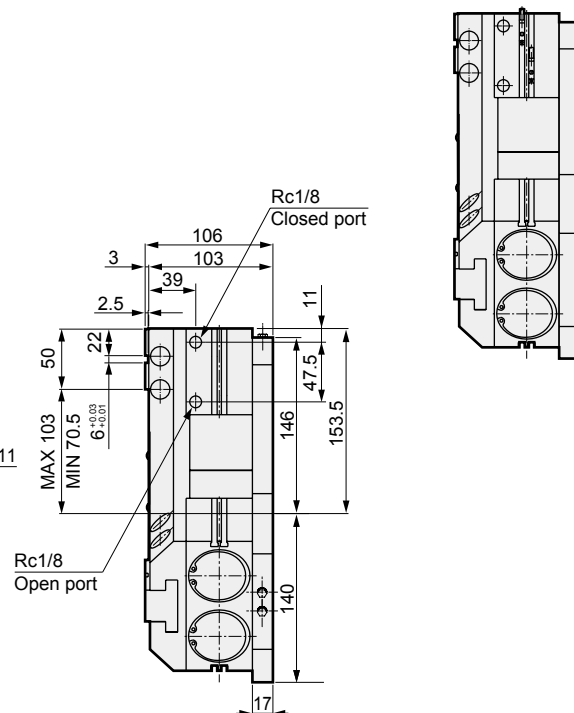

LCM
LCR
LCG
LCW
LCX
STM
STG
STS/STL
STR2
UCA2
ULK*
JSK/M2
JSG
JSC3/JSC4
USSD
UFCD
USC
UB
JSB3
LMB
LML
HCM
HCA
LBC
CAC4
UCAC2
CAC-N
UCAC-N
RCS2
RCC2
PCC
SHC
MCP
GLC
MFC
BBS
RRC
GRC
RV3*
NHS
HRL
LN
Hand
<b>Chuck</b>
MechHnd/Chuck
ShkAbs
FJ
FK
SpdContr
Ending
CKL2
CKL2
CKL2-HC
CKH2
CKLB2
CKG
CK
CKA
CKS
CKS-F
CKF
<b>CKJ</b>
CHC