

# ECG-A

Controller



## CONTENTS

Product introduction	Intro Page
● Specifications/How to order/Dimensions/System configuration	106
• Parallel I/O (PIO)	108
• IO-Link	112
• CC-Link	113
• EtherCAT	114
• EtherNet/IP	115
• Cables	116
• Related parts	117
⚠ Safety precautions	118

EBS  
(With motor)

EBR  
(With motor)

ECR  
(Controller)

ECG-A  
(Controller)

Safety  
precautions



# Controller ECG-A Series

All sizes of EBS-G and EBR-G can be operated with the same controller



## How to order

**ECG-ANNN30** - **NP** **A** **02**

### A Interface specifications

<b>NP</b>	Parallel I/O (NPN and PNP common)
<b>LK</b>	IO-Link
<b>CL</b>	CC-Link
<b>EC</b>	EtherCAT
<b>EN</b>	EtherNet/IP

### B Mounting method

<b>A</b>	Standard mount
<b>D</b>	DIN rail mount

### C IO cable length \*1

<b>00</b>	None
<b>02</b>	2 m
<b>03</b>	3 m
<b>05</b>	5 m
<b>10</b>	10 m

\*1 Select "None" when selecting interface specifications other than "Parallel I/O".

## System configuration

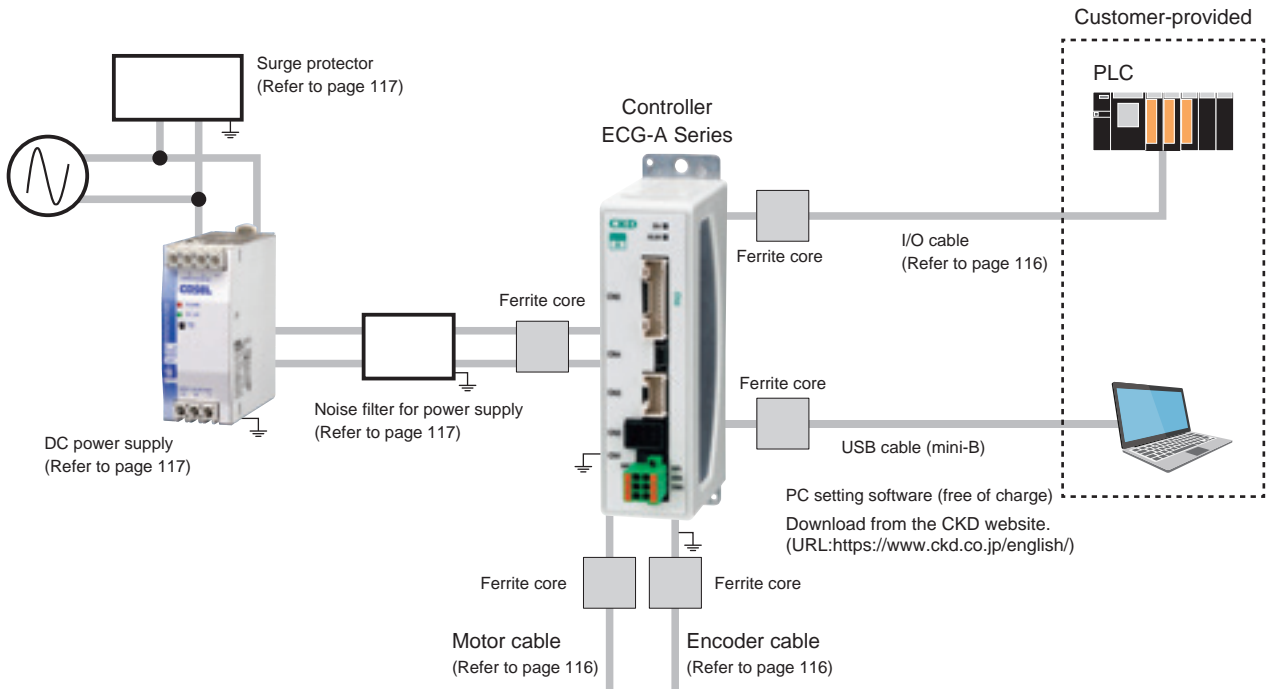

### Connectable actuators



EBS-G Series  
(Page 1)



EBR-G Series  
(Page 47)

\* Refer to the Instruction Manual for details on installing and wiring noise filters, surge protectors, and ferrite cores.

## General specifications

Item		Description		
Applicable actuators		EBS-G/EBR-G		
Applicable motor sizes		<input type="checkbox"/> 35	<input type="checkbox"/> 42	<input type="checkbox"/> 56
Settings tool		PC setting software (S-Tools) Connection cable: USB cable (mini-B)		
External interface	Parallel I/O specification	24 VDC $\pm$ 10%, input/output max. 13 points, cable length max. 10 m		
	Field network specification	IO-Link, CC-Link, EtherCAT, EtherNet/IP		
Display lamp		SV lamp, alarm lamp Communication status lamp (according to each interface specification)		
Power supply voltage	Control power	24 VDC $\pm$ 10%		
	Power supply	24 VDC $\pm$ 10%		
Current consumption	Control power	0.4 A or less		
	Power supply	1.7 A or less	1.9 A or less	2.8 A or less
Motor section max. instantaneous current		2.4 A or less	2.7 A or less	4.0 A or less
Brake current consumption		0.4 A or less		
Insulation resistance		10 M $\Omega$ and over at 500 VDC		
Withstand voltage		500 VAC for 1 minute		
Operating ambient temperature		0 to 40°C (no freezing)		
Operating ambient humidity		35 to 80% RH (no condensation)		
Storage ambient temperature		-10 to 50°C (no freezing)		
Storage ambient humidity		35 to 80% RH (no condensation)		
Working atmosphere		No corrosive gas, explosive gas, or dust		
Degree of protection		IP20		
Weight	Parallel I/O specification	Approx. 180 g (standard mount), approx. 210 g (DIN rail mount)		
	Field network specification	Approx. 310 g (standard mount), approx. 340 g (DIN rail mount)		

EBS  
(With motor)

EBR  
(With motor)

ECR  
(Controller)

ECG-A  
(Controller)

## Dimensions

### ● Standard mount

ECG-ANNN30-NPA□□ (Parallel I/O specification)

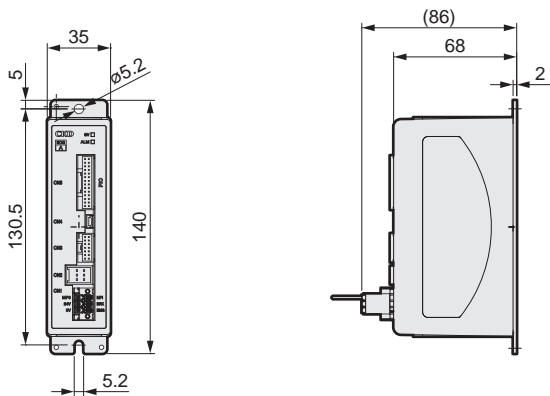

ECG-ANNN30-□□A□□ (Others)

\*This figure shows the dimensions for CC-Link specifications. The dimensions are the same for other interface specifications, except the connector part.

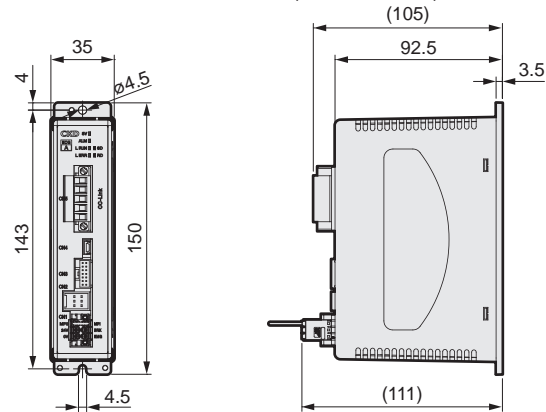

### ● DIN rail mount

ECG-ANNN30-NPD□□ (Parallel I/O specification)

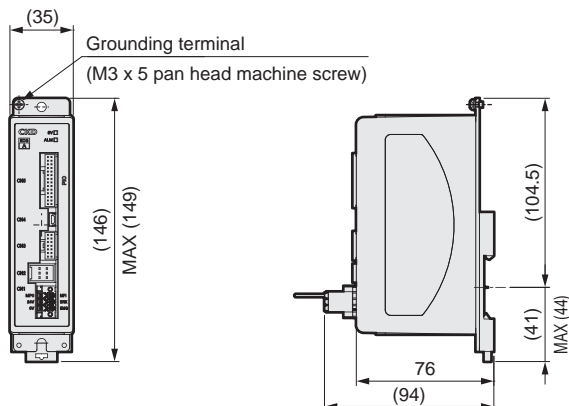

ECG-ANNN30-□□D□□ (Others)

\*This figure shows the dimensions for CC-Link specifications. The dimensions are the same for other interface specifications, except the connector part.

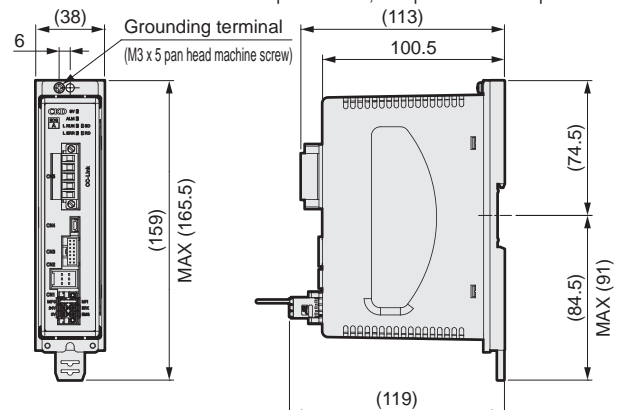

Safety  
precautions

## Parallel I/O (PIO) input/output circuit

### Input specification

Item	ECG-ANNN30-NP□□
No. of inputs	13 points
Input voltage	24 VDC ±10%
Input current	4 mA/point
Input voltage when ON	19 V or higher
Input current when OFF	0.2 mA or less

### Input circuit

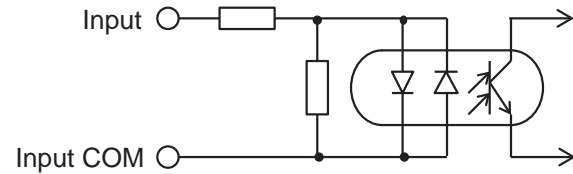

The input is not polarized.  
(The input COM can be used with either + or -)

### Output specifications

Item	ECG-ANNN30-NP□□
No. of I/O points	13 points
Load voltage	24 VDC ±10%
Load current	20 mA or less/point
Internal voltage drop when ON	3 V or less
Leakage current when OFF	0.1 mA or less
Output short-circuit protection circuit	Yes
Connecting load	PLC, etc.

### Output circuit

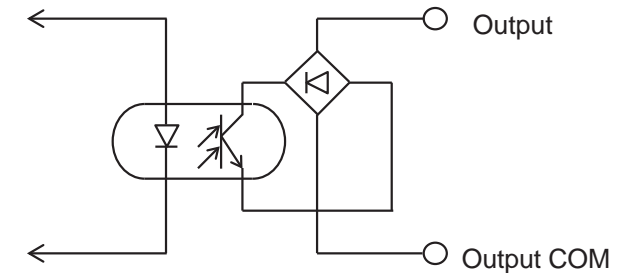

The output is not polarized.  
(The output COM can be used with either + or -)

## Parallel I/O (PIO) operation mode

Controllers offer five operation modes.

Use the PC setting software to set the appropriate operation mode. The initial setting is 64-point mode.

Operation mode	Positioning point count	Overview
64-point mode	64 points	<ul style="list-style-type: none"> <li>JOG travel start input</li> <li>Selectable output: 2 points (point zone, zone 1, zone 2, travel, warning)</li> </ul>
Simple 7-point mode	7 points	<ul style="list-style-type: none"> <li>JOG travel start input</li> <li>Selectable output: 2 points (point zone, zone 1, zone 2, travel, warning)</li> </ul>
Solenoid mode Double 2-position type	2 points	<ul style="list-style-type: none"> <li>SW output: 2 points</li> <li>Selectable output: 2 points (point zone, zone 1, zone 2, travel, warning)</li> </ul>
Solenoid mode Double 3-position type	2 points	<ul style="list-style-type: none"> <li>SW output: 2 points</li> <li>Selectable output: 2 points (point zone, zone 1, zone 2, travel, warning)</li> </ul>
Solenoid mode Single type	2 points	<ul style="list-style-type: none"> <li>SW output: 2 points</li> <li>Selectable output: 2 points (point zone, zone 1, zone 2, travel, warning)</li> </ul>

## Parallel I/O (PIO) signal name list

### Input signal

Abbreviation	Name	Abbreviation	Name
PST	Point travel start	JOGM	JOG(-) travel start
PSB*	Point No. selection bit*	JOGP	JOG(+) travel start
OST	Origin return start	P*ST	Point No. * travel start
SVON	Servo ON	V1ST	Solenoid valve travel instruction 1
ALMRST	Alarm reset	V2ST	Solenoid valve travel instruction 2
STOP	Stop	VST	Solenoid valve travel instruction

### Output signal

Abbreviation	Name	Abbreviation	Name
PEND	Point travel complete	SONS	Servo ON state
PCB*	Point No. confirmation bit *	ALM	Alarm
ACB*	Alarm confirmation bit *	WARN	Warning
PZONE	Point zone	READY	Operation preparation complete
MOVE	Moving	P*END	Point number * travel complete
ZONE1	Zone 1	SW1	Switch 1
ZONE2	Zone 2	SW2	Switch 2
OEND	Origin return complete		

### Parallel I/O (PIO) operation mode and signal assignment

The following figure shows signal assignments in each operation mode.

Operation mode		64-point mode	Simple 7-point mode	Solenoid mode Double 2-position type	Solenoid mode Double 3-position type	Solenoid mode Single type
Positioning point count		64	7	2	2	2
Input	IN0	PSB0	P1ST	V1ST	V1ST	-
	IN1	PSB1	P2ST	V2ST	V2ST	VST
	IN2	PSB2	P3ST	-	-	-
	IN3	PSB3	P4ST	-	-	-
	IN4	PSB4	P5ST	-	-	-
	IN5	PSB5	P6ST	-	-	-
	IN6	PST	P7ST	-	-	-
	IN7	JOGM	JOGM	-	-	-
	IN8	JOGP	JOGP	-	-	-
	IN9	OST	OST	OST	OST	OST
	IN10	SVON	SVON	SVON	SVON	SVON
	IN11	ALMRST	ALMRST	ALMRST	ALMRST	ALMRST
	IN12	STOP#	STOP#	-	-	-
Output	OUT0	PCB0/ ACB0	P1END	P1END	P1END	P1END
	OUT1	PCB1/ ACB1	P2END	P2END	P2END	P2END
	OUT2	PCB2/ ACB2	P3END	-	-	-
	OUT3	PCB3/ ACB3	P4END	-	-	-
	OUT4	PCB4	P5END	SW1	SW1	SW1
	OUT5	PCB5	P6END	SW2	SW2	SW2
	OUT6	PEND	P7END	-	-	-
	OUT7	PZONE/ ZONE1/ ZONE2/ MOVE/ WARN#	PZONE/ ZONE1/ ZONE2/ MOVE/ WARN#	PZONE/ ZONE1/ ZONE2/ MOVE/ WARN#	PZONE/ ZONE1/ ZONE2/ MOVE/ WARN#	PZONE/ ZONE1/ ZONE2/ MOVE/ WARN#
	OUT8	PZONE/ ZONE1/ ZONE2/ MOVE/ WARN#	PZONE/ ZONE1/ ZONE2/ MOVE/ WARN#	PZONE/ ZONE1/ ZONE2/ MOVE/ WARN#	PZONE/ ZONE1/ ZONE2/ MOVE/ WARN#	PZONE/ ZONE1/ ZONE2/ MOVE/ WARN#
	OUT9	OEND	OEND	OEND	OEND	OEND
	OUT10	SONS	SONS	SONS	SONS	SONS
	OUT11	ALM#	ALM#	ALM#	ALM#	ALM#
	OUT12	READY	READY	READY	READY	READY

\* The pound sign (#) indicates a negative logic signal.

EBS  
(With motor)

EBR  
(With motor)

ECR  
(Controller)

ECG-A  
(Controller)

Safety  
precautions

EBS  
(With motor)

EBR  
(With motor)

ECR  
(Controller)

ECG-A  
(Controller)

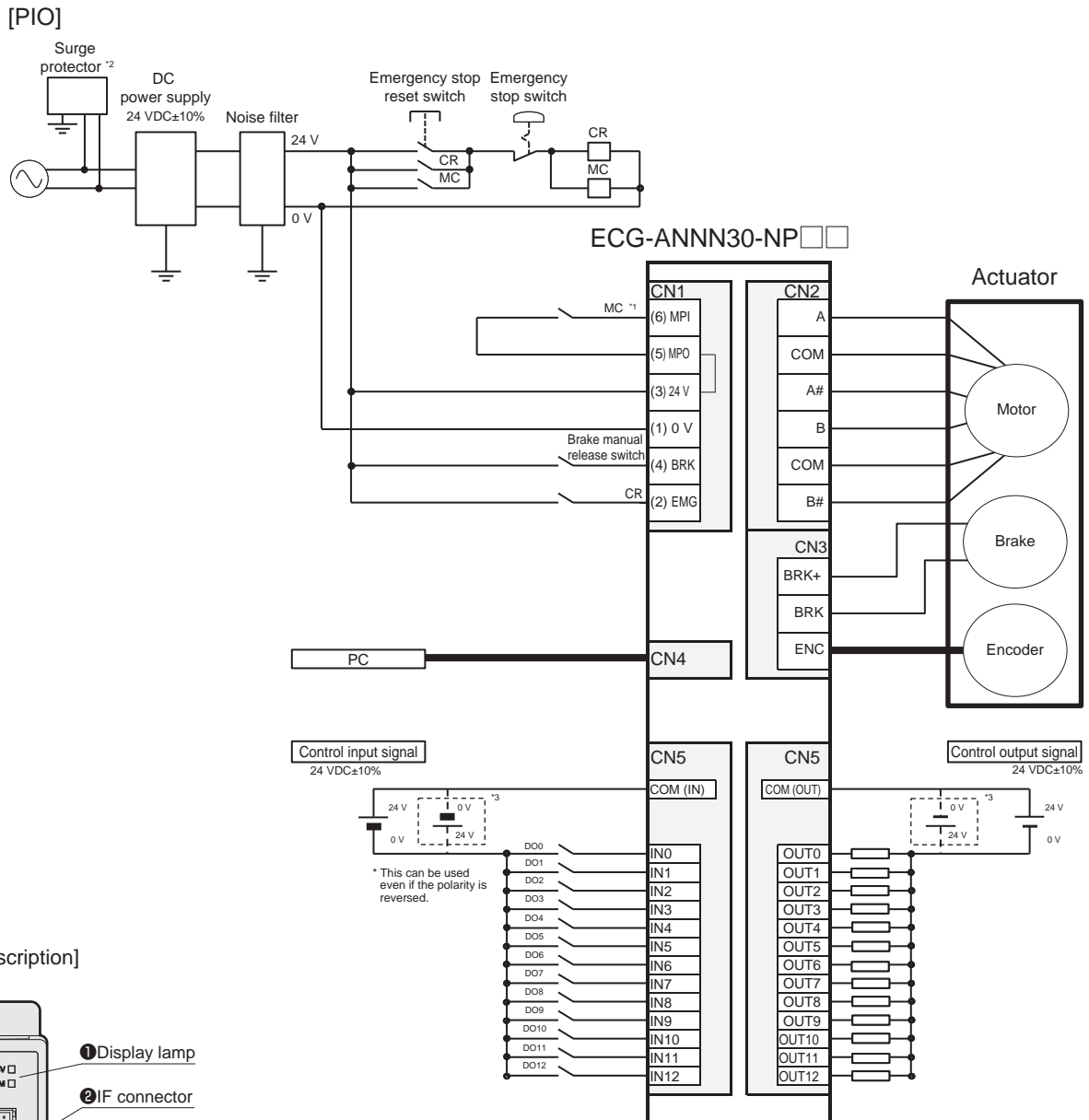

**[Panel description]**

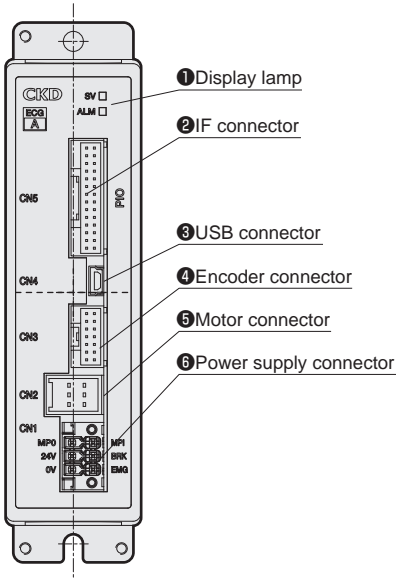

\*1 For safety category support, connect the contact of an electromagnetic switch or other device between the MPI and MPO terminals when motor drive power must be shut OFF. (Connected with jumper wires at shipment.)

\*2 A surge protector is required to comply with the CE marking.

\*3 This can be used even if the polarity is reversed.

● Accessories

Part name	Manufacturer model	Manufacturer
Power supply connector	DFMC1, 5/3-STF-3, 5	PHOENIX CONTACT

### Description of field network operation modes

Operation mode	Overview
PIO mode (PIO)	Point operation can be used and signal assignment of inputs and outputs can be changed in the operation mode (PIO) in the same manner as with the parallel I/O specification. However, you cannot select a direct-value operation that sets the operating conditions for operation directly from the PLC. Reading and writing of parameters do work, but the monitoring function cannot be used. Refer to the table below for details.
Half simple direct value mode (HSDP)	This mode is selectable only with the CC-Link specification controller. Switching the direct travel selection signal enables a target position to be arbitrarily be set by the PLC or 64 point operation. The selected direct travel operation method can then be used. The monitoring function can be used with restrictions. Reading and writing of parameters does not work. Refer to the table below for details.
Simple direct value mode (SDP)	Switching the direct travel selection signal enables a target position to be arbitrarily be set by the PLC or 64 point operation. The selected direct travel operation method can then be used. Reading and writing of parameters do work and the monitoring function can be used. Refer to the table below for details.
Half direct value mode (HDP)	This mode is selectable only with the CC-Link specification controller. Switching the direct travel selection signal enables operating conditions to be arbitrarily be set by a PLC (with restrictions) or 64 point operation. The selected direct travel operation method can then be used. The monitoring function can be used. Reading and writing of parameters does not work. Refer to the table below for details.
Full direct value mode (FDP)	Switching the direct travel selection signal enables operating conditions to be arbitrarily be set by the PLC or 64 point operation. The selected direct travel operation method can then be used. Reading and writing of parameters do work and the monitoring function can be used. Refer to the table below for details.

Operation mode	PIO	HSDP	SDP	HDP	FDP
Parameter read/write	Available	Not available	Available	Not available	Available
Direct value travel selection *1	Selection not possible	1	1	1	1
Positioning point count	64	Unlimited	Unlimited	Unlimited	Unlimited
Direct value travel item *2	Target position	-	○	○	○
	Positioning width	-	-	-	○
	Speed	-	-	-	○
	Acceleration	-	-	-	●
	Deceleration	-	-	-	●
	Pressing rate	-	-	-	○
	Pressing distance	-	-	-	○
	Pressing speed	-	-	-	-
	Position specification method	-	-	-	○
	Operation mode	-	-	-	○
	Stop method	-	-	-	○
Monitor item *3	Position	-	○	○	○
	Speed	-	○	▲	○
	Current	-	○	▲	○
	Alarm	-	-	▲	○

\*1: When the direct value travel selection is 0, it operates with the value set by the point data. This enables up to 64 positioning points.

\*2: ○ indicates items operated with the value set by the PLC.

- indicates operation with the value set by the point data.

● indicates items operated with the value set by the PLC, but only the same values can be set.

\*3: ○ indicates items that can be monitored.

- indicates items that cannot be monitored.

Use ▲ to select only 1 item to be monitored.

▲ indicates items can be monitored when selected as monitor values (one at a time for CC-Link and IO-Link, three values at a time for others).

EBS  
(With motor)

EBR  
(With motor)

ECR  
(Controller)

ECG-A  
(Controller)

Safety  
precautions

## IO-Link specifications and connection diagram (ECG-ANNN30-LK<sup>\*\*</sup>)

### [Communication specifications]

Item	Specifications
Communication protocol Version	V1.1
Transmission bit rate	COM3(230.4kbps)
Port	Class A
Process data length (Input) PD (in) data length	PIO mode: 2 bytes
	Simple direct value mode: 9 bytes
	Full direct value mode: 12 bytes
Process data length (Output) PD (out) data length	PIO mode: 2 bytes
	Simple direct value mode: 7 bytes
	Full direct value mode: 22 bytes
Minimum cycle Time	PIO mode: 1 ms
	Simple direct value mode: 1.5 ms
	Full direct value mode: 2.5 ms
Monitor function	Position, speed, current, alarm

\* Items that can be monitored change depending on the operation mode. Refer to page 111 for details.

### [IO-Link]

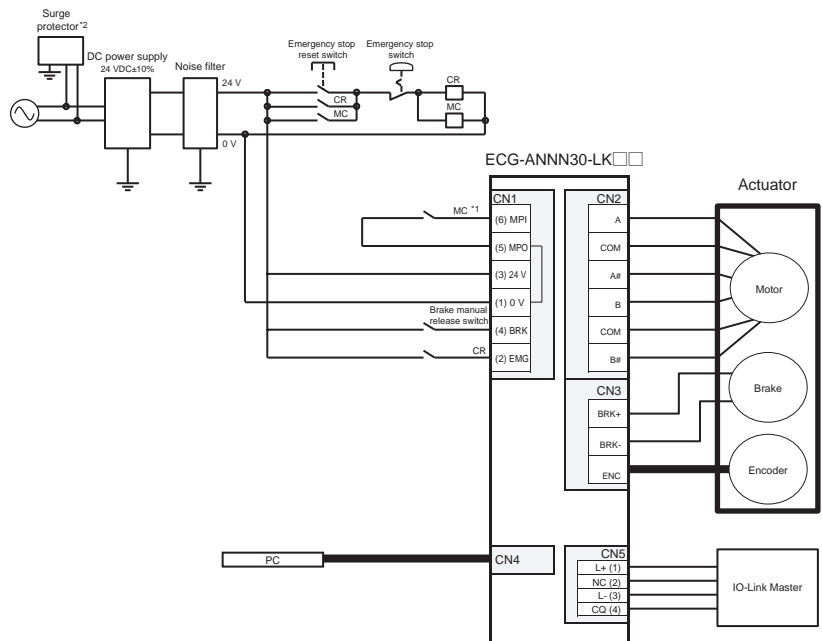

\*1 For safety category support, connect the contact of an electromagnetic switch or other device between the MPI and MPO terminals when motor drive power must be shut OFF.  
(Connected with jumper wires at shipment.)

\*2 A surge protector is required to comply with the CE marking.

EBB  
(With motor)

EBR  
(With motor)

ECR  
(Controller)

ECG-A  
(Controller)

Safety  
precautions

### [Panel description]

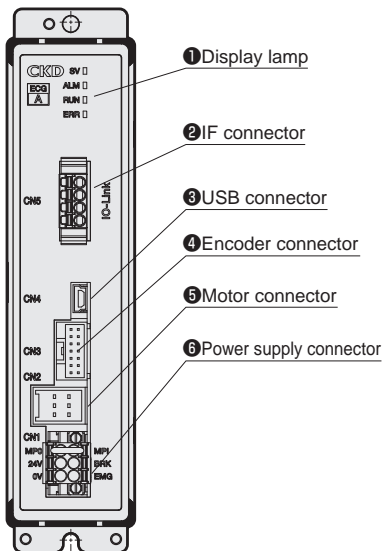

### Cyclic data from master

PD (out)	bit	Full direct value mode
		Signal name
0	7	Pause#
	6	Stop#
	5	Alarm reset
	4	Servo ON
	3	Origin return start
	2	Point travel start
	1	JOG/INCH (+) travel start
	0	JOG/INCH (-) travel start
1	7	INCH selection
	6	-
5 to 0	5 to 0	Point number selection bit 5 to 0
	7 to 4	-
2	3 to 1	Rotation direction (direct value travel)
	0	Direct value travel selection
3 to 6	7 to 0	Position (direct value travel)
	7 to 8	Positioning width (direct value travel)
	9 to 10	Speed (direct value travel)
	11	Acceleration (direct value travel)
	12	Deceleration (direct value travel)
	13	Pressing rate (direct value travel)
	14	Pressing speed (direct value travel)
	15 to 18	Pressing distance (direct value travel)
	19 to 20	Gain magnification (direct value travel)
	21	7
6 to 5		Operation mode (direct value travel)
4 to 3		Acceleration/deceleration method (direct value travel)
2 to 0		Stop method (direct value travel)

### Cyclic data from controller

PD (in)	bit	Full direct value mode
		Signal name
0	7	Operation preparation complete
	6	Warning#
	5	Alarm#
	4	Servo ON state
	3	Origin return complete
	2	Point travel complete
1	1 to 0	-
	7 to 6	-
2	5 to 0	Point travel confirmation bit 5 to 0
	7 to 5	-
	4	Zone 2
	3	Zone 1
	2	Moving
3 to 6	1	Point zone
	0	Direct travel status
	7 to 0	Position (monitor value)
	7 to 8	Speed (monitor value)
	9	Current (monitor value)
10 to 11	7 to 0	Alarm (monitor value)

\* Refer to the Instruction Manual for details of other operation modes.

\* The pound sign (#) indicates a negative logic signal.

### ● Accessories

Part name	Manufacturer model	Manufacturer
Power supply connector	DFMC 1,5/3-STF-3,5	PHOENIX CONTACT
IO-Link connector	FMC1,5/4-ST-3,5-RF	PHOENIX CONTACT



### CC-Link specifications and connection diagram (ECG-ANNN30-CL\*\*)

#### [Communication specifications]

Item	Specifications
CC-Link Version	Ver. 1.10
Station	Remote device station
Remote station No.	1 to 64 (set by parameter setting)
Operation mode	PIO mode (1 station occupied)
	Half simple direct value mode (1 stations occupied)
	Simple direct value mode (2 stations occupied)
	Half direct value mode (2 stations occupied)
	Full direct value mode (4 stations occupied)
Number of occupied stations	
Remote I/O points	32 points x number of occupied stations
Remote Register input/output	4 words x number of occupied stations
Communication speed	10M/5M/2.5M/625k/156kbps (Selected by parameter setting)
Connection cable	CC-Link Ver. 1.10. compliant cable (3 core twisted pair cable with shield)
Number of connected units	42 max. when only remote device stations are connected
Monitor function	Position, speed, current, alarm

\* Items that can be monitored change depending on the operating mode. Refer to page 111 for details.

#### [CC-Link]

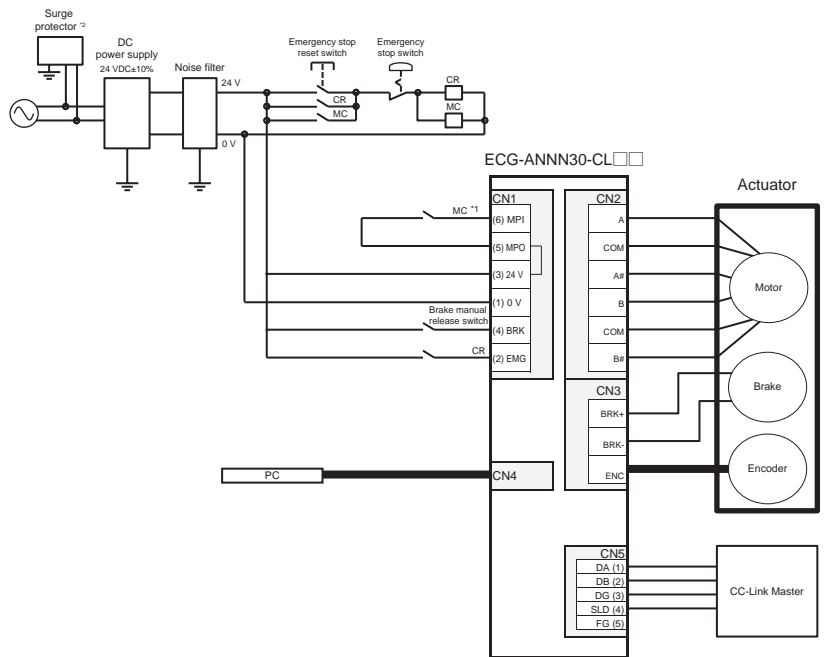

\*1 For safety category support, connect the contact of an electromagnetic switch or other device between the MPI and MPO terminals when motor drive power must be shut OFF. (Connected with jumper wires at shipment.)

\*2 A surge protector is required to comply with the CE marking.

#### [Panel description]

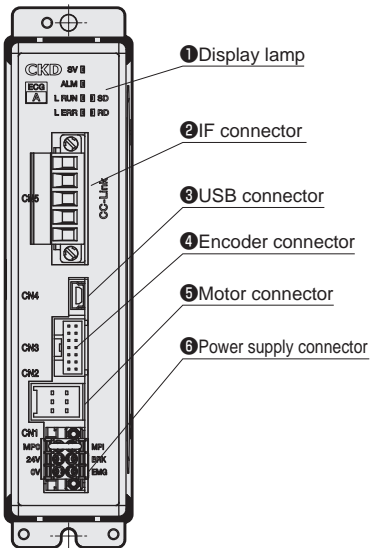

#### Cyclic data from master

Device No.	Half simple direct value mode	
	Signal name	
RYn0	Point number selection bit 0	
RYn1	Point number selection bit 1	
RYn2	Point number selection bit 2	
RYn3	Point number selection bit 3	
RYn4	Point number selection bit 4	
RYn5	Point number selection bit 5	
RYn6	Direct value travel selection	
RYn7	JOG/INCH (-) travel start	
RYn8	JOG/INCH (+) travel start	
RYn9	INCH selection	
RYnA	Point travel start	
RYnB	Origin return start	
RYnC	Servo ON	
RYnD	Alarm reset	
RYnE	Stop#	
RYnF	Pause#	
RY (n+1) 0 to RY (n+1) F	Vacant	

Device No.	Half simple direct value mode	
	Signal name	
RWw0	Position (direct value travel)	
RWw1		
RWw2	-	
RWw3	-	

\* Refer to the Instruction Manual for details of other operation modes.  
\* The pound sign (#) indicates a negative logic signal.

#### Cyclic data from controller

Device No.	Half simple direct value mode	
	Signal name	
RXn0	Point number confirmation bit 0	
RXn1	Point number confirmation bit 1	
RXn2	Point number confirmation bit 2	
RXn3	Point number confirmation bit 3	
RXn4	Point number confirmation bit 4	
RXn5	Point number confirmation bit 5	
RXn6	Direct value travel status	
RXn7	Selectable output 1	
RXn8	Selectable output 2	
RXn9	-	
RXnA	Point travel complete	
RXnB	Origin return complete	
RXnC	Servo ON state	
RXnD	Alarm#	
RXnE	Warning#	
RXnF	Operation preparation complete	
RX (n+1) 0 to RX (n+1) F	Vacant	

Device No.	Half simple direct value mode	
	Signal name	
RWr0	Position (monitor value)	
RWr1	Position (monitor value)	
RWr2	Speed (monitor value)	
RWr3	Current (monitor value)	

#### ● Accessories

Part name	Manufacturer model	Manufacturer
Power supply connector	DFMC1, 5/3-STF-3, 5	PHOENIX CONTACT
CC-Link connector	MSTB2, 5/5-STF-5, 08ABGYAU	PHOENIX CONTACT

EBS (With motor)  
 EBR (With motor)  
 ECR (Controller)  
 ECG-A (Controller)  
 Safety precautions

## EtherCAT specifications and connection diagram (ECG-ANNN30-EC\*\*)

### [Communication specifications]

Item	Specifications
Communication speed	100 Mbps (fast Ethernet, full duplex)
Process data	Variable PDO mapping
Max. PDO data length	RxPDO: 64 bytes/ TxPDO: 64 bytes
Station alias	0 to 65535 (set by parameters)
Connection cable	EtherCAT compliant cable (CAT5e or higher twisted pair cable (double shield with aluminum tape and braid) is recommended.)
Node address	Automatic indexing the master
Monitor function	Position, speed, current, alarm

\* Items that can be monitored change depending on the operation mode. Refer to page 111 for details.

### [EtherCAT]

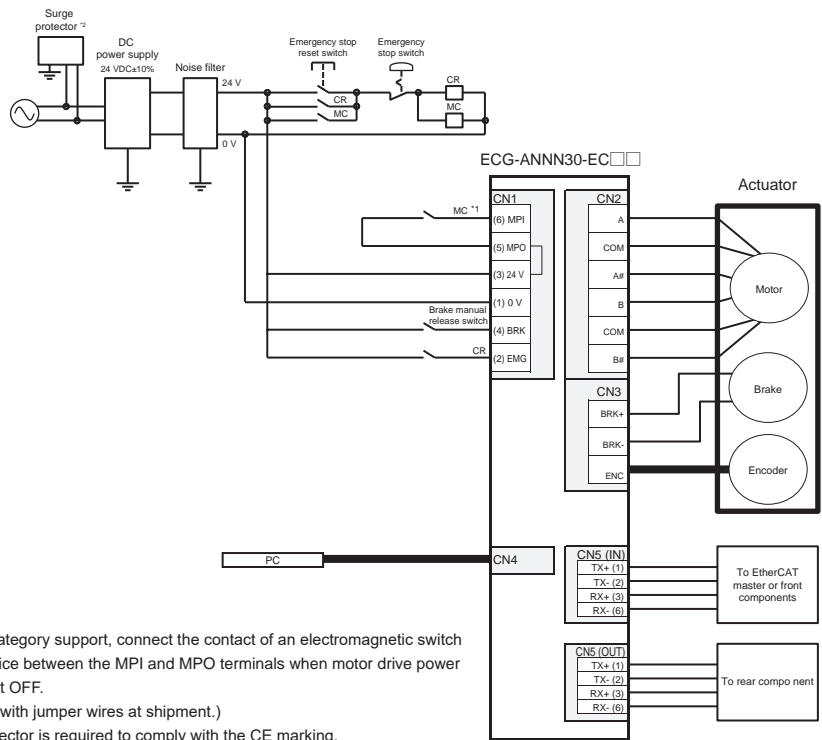

\*1 For safety category support, connect the contact of an electromagnetic switch or other device between the MPI and MPO terminals when motor drive power must be shut OFF.  
(Connected with jumper wires at shipment.)

\*2 A surge protector is required to comply with the CE marking.

### Cyclic data from master

Index	Sub Index	bit	Full direct value mode		
			Signal name		
0x2001	0x01	0 to 5	Point number selection bit 0 to 5		
		6	-		
		7	JOG/INCH (-) travel start		
		8	JOG/INCH (+) travel start		
		9	INCH selection		
		10	Point travel start		
		11	Origin return start		
		12	Servo ON		
		13	Alarm reset		
		14	Stop#		
		15	Pause#		
		16 to 31	-		
		0x2003	0x02	0 to 3	-
				4	Data request
				5	Data R/W selection
6 to 11	-				
12	Monitor request				
13 to 14	-				
15	Direct value travel selection				
16 to 31	-				
0x2007	0x01			0 to 31	Position (direct value travel)
				0 to 31	Positioning width (direct value travel)
				0 to 31	Speed (direct value travel)
				0 to 31	Acceleration (direct value travel)
				0 to 31	Deceleration (direct value travel)
				0 to 31	Pressing rate (direct value travel)
				0 to 31	Pressing speed (direct value travel)
		0 to 31	Pressing distance (direct value travel)		
		0 to 31	Mode (direct value travel)		
		0 to 31	Gain magnification (direct value travel)		
		0 to 31	Write data		
		0 to 31	Data number		
		0 to 31	Monitor number 1		
		0 to 31	Monitor number 2		

### Cyclic data from controller

Index	Sub Index	bit	Full direct value mode		
			Signal name		
0x2005	0x01	0 to 5	Point number selection bit 0 to 5		
		6 to 9	-		
		10	Point travel complete		
		11	Origin return complete		
		12	Servo ON state		
		13	Alarm#		
		14	Warning#		
		15	Operation preparation complete		
		16 to 31	-		
		0x2007	0x02	0 to 3	Data response
				4	Data complete
				5	Data write status
				6 to 7	-
				8 to 11	Monitor response
				12	Monitor complete
13 to 14	-				
15	Direct travel status				
16	Point zone				
17	Moving				
18	Zone 1				
19	Zone 2				
20 to 31	-				
0x2007	0x01			0 to 31	Position (monitor value)
				0 to 31	Speed (monitor value)
		0 to 31	Current (monitor value)		
		0 to 31	-		
		0 to 31	Alarm (monitor value)		
		0 to 31	-		
		0 to 31	Read data		
		0 to 31	Data (alarm)		
		0 to 31	Monitor value 1		
		0 to 31	Monitor value 2		

\* Refer to the Instruction Manual for details of other operation modes.

\* The pound sign (#) indicates a negative logic signal.

### [Panel description]

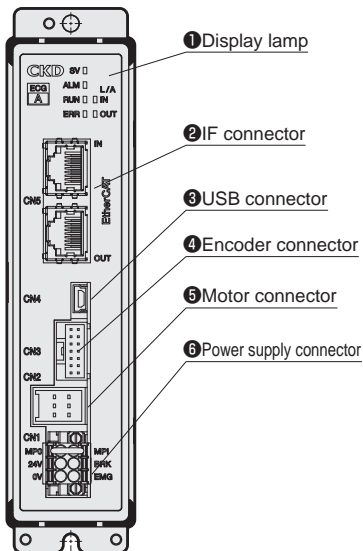

### ● Accessories

Part name	Manufacturer model	Manufacturer
Power supply connector	DFMC 1,5/3-STF-3,5	PHOENIX CONTACT

### EtherNet/IP specifications and connection diagram (ECG-ANNN30-EN\*\*)

#### [Communication specifications]

Item	Specifications
Communication protocol	EtherNet/IP
Communication speed	Automatic setting (100 Mbps/10 Mbps, full duplex/half duplex)
Occupied bytes	Input: 64 bytes / Output: 64 bytes
IP address	Setting by parameter (0.0.0.0 to 255.255.255.255) Via DHCP Server (arbitrary address)
RPI (Packet interval)	4 ms to 10000 ms
Connection cable	EtherNet/IP compliant cable (CAT5e or higher twisted pair cable (double shield with aluminum tape and braid) is recommended.)
Monitor function	Position, speed, current, alarm

\* Items that can be monitored change depending on the operation mode. Refer to page 111 for details.

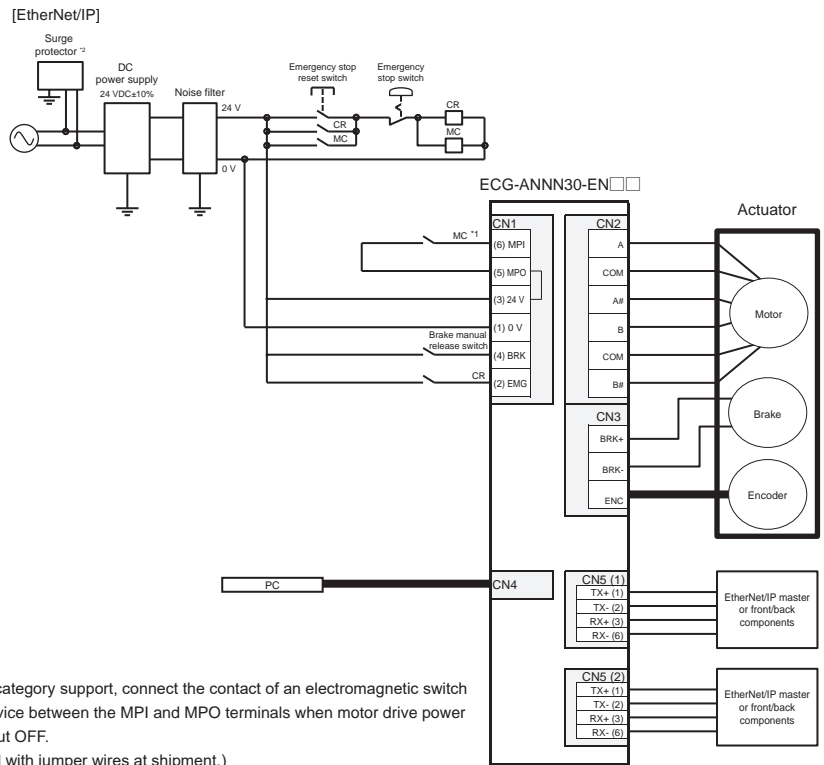

\*1 For safety category support, connect the contact of an electromagnetic switch or other device between the MPI and MPO terminals when motor drive power must be shut OFF.  
(Connected with jumper wires at shipment.)

\*2 A surge protector is required to comply with the CE marking.

#### Cyclic data from master

Byte	bit	Full direct value mode
		Signal name
0	0 to 5	Point number selection bit 0 to 5
	6	-
	7	JOG/INCH (-) travel start
1	0	JOG/INCH (+) travel start
	1	INCH selection
	2	Point travel start
	3	Origin return start
	4	Servo ON
	5	Alarm reset
	6	Stop#
	7	Pause#
2 to 3	0 to 7	-
	0 to 3	-
4	4	Data request
	5	Data R/W selection
	6 to 7	-
5	0 to 3	-
	4	Monitor request
	5 to 6	-
6 to 7	0 to 7	-
	0 to 7	Position (direct value travel)
12 to 15	0 to 7	Positioning width (direct value travel)
16 to 19	0 to 7	Speed (direct value travel)
20 to 23	0 to 7	Acceleration (direct value travel)
24 to 27	0 to 7	Deceleration (direct value travel)
28 to 31	0 to 7	Pressing rate (direct value travel)
32 to 35	0 to 7	Pressing speed (direct value travel)
36 to 39	0 to 7	Pressing distance (direct value travel)
40 to 43	0 to 7	Mode (direct value travel)
44 to 47	0 to 7	Gain magnification (direct value travel)
48 to 51	0 to 7	Write data
52 to 55	0 to 7	Data number
56 to 59	0 to 7	Monitor number 1
60 to 63	0 to 7	Monitor number 2

#### Cyclic data from controller

Byte	bit	Full direct value mode
		Signal name
0	0 to 5	Point number selection bit 0 to 5
	6 to 7	-
	0 to 1	-
1	2	Point travel complete
	3	Origin return complete
	4	Servo ON state
	5	Alarm#
	6	Warning#
	7	Operation preparation complete
	2 to 3	0 to 7
0 to 3		Data response
4		Data complete
4	5	Data write status
	6 to 7	-
	0 to 3	Monitor response
5	4	Monitor complete
	5 to 6	-
6	7	Direct travel status
	0	Point zone
	1	Moving
	2	Zone 1
7	3	Zone 2
	4 to 7	-
8 to 11	0 to 7	Position (monitor value)
	0 to 7	Speed (monitor value)
	0 to 7	Current (monitor value)
20 to 23	0 to 7	-
	0 to 7	Alarm (monitor value)
28 to 47	0 to 7	-
	0 to 7	Read data
52 to 55	0 to 7	Data (alarm)
56 to 59	0 to 7	Monitor value 1
60 to 63	0 to 7	Monitor value 2

\* Refer to the Instruction Manual for details of other operation modes.

\* The pound sign (#) indicates a negative logic signal.

#### [Panel description]

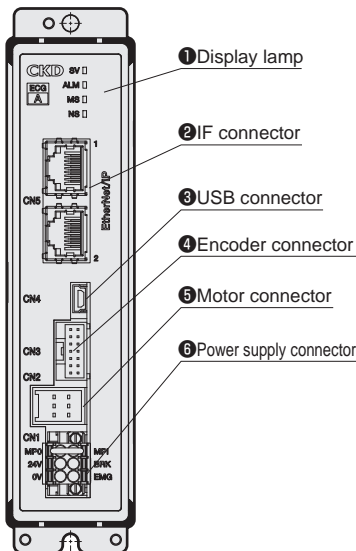

#### Accessories

Part name	Manufacturer model	Manufacturer
Power supply connector	DFMC 1,5/3-STF-3,5	PHOENIX CONTACT

EBS (With motor)  
EBR (With motor)  
ECR (Controller)  
ECG-A (Controller)

Safety precautions

## Relay cable

### ● Motor cable (fixed/movable)

\* Can be selected with actuator model

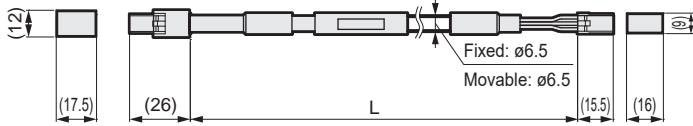

**EA-CBLM2 - S 01**

A B

A Cable type	
S	Fixed cable
R	Movable cable

B Cable length	
01	1 m
03	3 m
05	5 m
10	10 m

### ● Encoder cable (fixed/movable)

\* Can be selected with actuator model

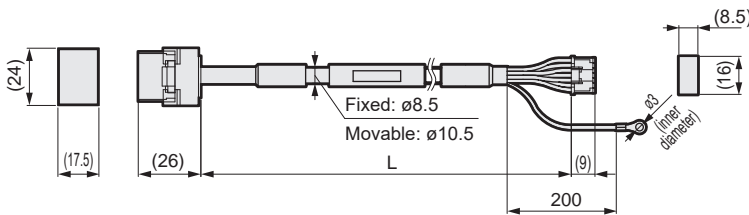

**EA-CBLE2 - S 01**

A B

A Cable type	
S	Fixed cable
R	Movable cable

B Cable length	
01	1 m
03	3 m
05	5 m
10	10 m

## I/O cable

### ● I/O cable

\* Parallel I/O specification controller model can be selected

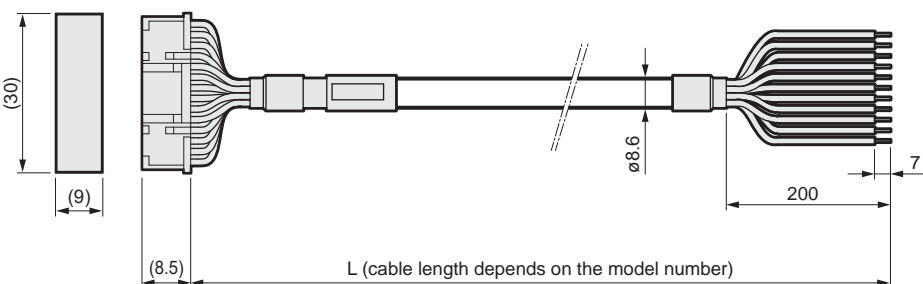

**EA-CBLNP2 - 02**

A

A Cable length	
02	2 m
03	3 m
05	5 m
10	10 m

EBS  
(With motor)

EBR  
(With motor)

ECR  
(Controller)

ECG-A  
(Controller)

Safety  
precautions

## Related parts model No. table

### ● DC power supply



Model No.		EA-PWR-KHNA240F-24-N2 (screw mounted) EA-PWR-KHNA240F-24 (DIN rail mounted)	
Item			
Manufacturer		COSEL Co., Ltd.	
Manufacturer Model No.	Mounting screw	KHNA240F-24-N2	
	DIN rail mount	KHNA240F-24	
Input voltage		85 to 264 VAC 1ϕ or 88 to 370 VDC	
Output	Power	240 W	
	Voltage/current	24 V 10 A	
	Variable voltage range	22.5 to 28.5 V	
Included functions	Overcurrent protection	Operating at 101% min of peak current	
	Overvoltage protection	30.0 to 36.0 V	
	Remote control	Available	
	Remote sensing	-	
Others		DC_OK display, ALARM display	
Operating temperature/humidity		-25 to +70 °C, 20 to 90% RH (no condensation), startup possible at -40 °C *	
Applicable standards	Safety standards	AC input	AC input: Certified UL60950-1, C-UL (CSA60950-1), EN60950-1 UL508, ANSI / ISA12.12.01, and ATEX; Electrical Appliances and Material Safety Act compliant *
		DC input	Certified UL60950-1, C-UL (CSA60950-1), EN60950-1
	Noise terminal voltage	Compliant with FCC-B, VCCI-B, CISPR22-B, EN55011-B, EN55022-B	
	Harmonic current	Compliant with IEC61000-3-2 (class A) *	
Structure	Dimensions (W x H x D)	50x124x117 mm	
	Weight	900 g max	
	Cooling method	Natural air cooling	

\* Refer to the manufacturer's website for details.

\* CE and ROHS certification has been obtained under the manufacturer's model number.

EBS  
(With motor)  
EBR  
(With motor)  
ECR  
(Controller)  
ECG-A  
(Controller)

### Part names and dimensions

#### ● EA-PWR-KHNA240F-24-N2 (24 V screw mounted)

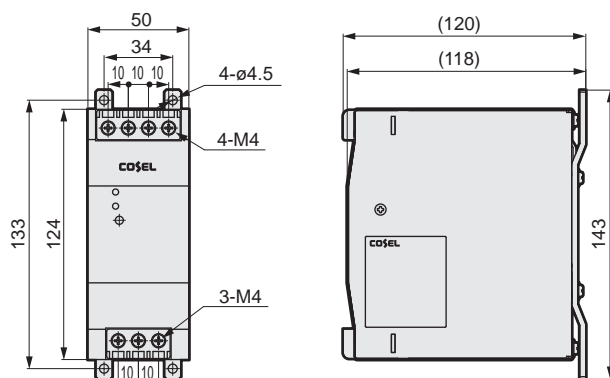

#### ● EA-PWR-KHNA240F-24 (24 V DIN rail mounted)

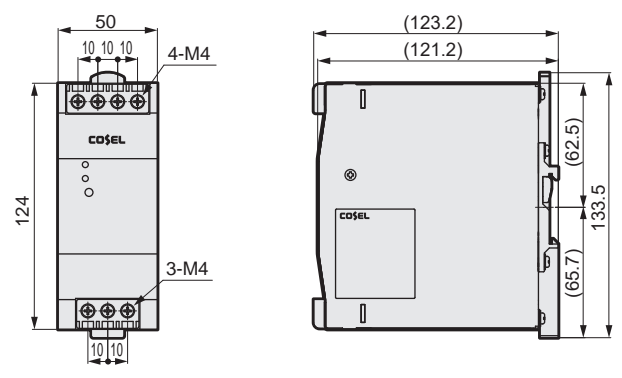

Safety  
precautions

### ● Other parts

Part name	Model No.
Noise filter for power supply (single phase, 15 A)	AX-NSF-NF2015A-OD
Surge protector	AX-NSF-RAV-781BXZ-4

\* Refer to the Instruction Manual for details on the ferrite core to be used.